

Technical Support Center: Gamma-Secretase Modulator (GSM) Cell-Based Assays

Author: BenchChem Technical Support Team. **Date:** April 2026

Compound of Interest

Compound Name: Nivegaceter
CAS No.: 2443487-67-8
Cat. No.: B15620104

[Get Quote](#)

Welcome to the technical support center for gamma-secretase modulator (GSM) cell-based assays. This resource provides troubleshooting guides and frequently asked questions (FAQs) to help researchers, scientists, and drug development professionals overcome common challenges encountered during their experiments.

Frequently Asked Questions (FAQs)

Q1: What is the mechanism of action of gamma-secretase modulators (GSMs)?

A1: Gamma-secretase modulators are small molecules that allosterically bind to the γ -secretase complex.^[1] Instead of inhibiting the enzyme's overall activity, they alter its processivity.^[2] This modulation results in a shift in the cleavage site of the amyloid precursor protein (APP), leading to a decrease in the production of longer, more amyloidogenic amyloid-beta (A β) peptides, such as A β 42, and a concurrent increase in the production of shorter, less aggregation-prone A β peptides like A β 38 and A β 37.^{[1][3]} Importantly, GSMs typically do not inhibit the cleavage of other γ -secretase substrates, such as Notch, which is a significant advantage over pan- γ -secretase inhibitors that can cause toxicity due to Notch-related side effects.^{[1][3]}

Q2: How do I choose the right cell line for my GSM assay?

A2: The choice of cell line is critical for a successful GSM assay. Commonly used cell lines include human embryonic kidney (HEK293) and Chinese hamster ovary (CHO) cells.[4][5][6]

Key considerations include:

- Expression of APP and γ -secretase components: The cell line must endogenously express or be engineered to express the necessary components of the γ -secretase pathway. Many researchers use cell lines stably overexpressing human APP or its C-terminal fragments (e.g., C99) to enhance the signal window for A β detection.[7]
- Secretory pathway characteristics: Differences in the secretory pathways between cell lines, such as HEK293 and CHO, can impact the production and secretion of A β peptides.[4]
- Genetic stability: It is crucial to use a cell line with stable expression of the target proteins over multiple passages. Genetic instability can lead to variable A β production and inconsistent assay results.[8][9][10][11] Regular characterization of the cell bank is recommended.[10][11]
- Assay format compatibility: The chosen cell line should be amenable to the specific assay format (e.g., adherent for imaging-based assays, suspension for high-throughput screening).

Q3: What are typical assay quality control parameters I should aim for?

A3: To ensure the robustness and reliability of your GSM cell-based assay, it is important to monitor key quality control parameters. These include:

- Z'-factor: This parameter reflects the separation between the positive and negative controls and is a measure of assay quality. For cell-based assays, a Z'-factor between 0.4 and 1.0 is generally considered acceptable, while a Z'-factor between 0.5 and 1.0 is excellent for biochemical assays.[12]
- Signal-to-Background (S/B) Ratio: This ratio indicates the dynamic range of the assay. A higher S/B ratio is desirable as it allows for better discrimination between active and inactive compounds.

- Coefficient of Variation (%CV): This measures the variability of the data. A lower %CV indicates higher precision.

Troubleshooting Guide

Problem 1: High variability in A β 42/A β 40 ratio measurements.

Possible Causes and Solutions:

Possible Cause	Troubleshooting Step
Cellular Health and Plating Inconsistency	Ensure consistent cell seeding density and uniform cell health across the plate. Avoid edge effects by not using the outer wells or by filling them with sterile media or water. [13] [14] [15] [16] [17]
Compound Precipitation	Visually inspect for compound precipitation in the wells. Ensure the final DMSO concentration is consistent across all wells and does not exceed a level toxic to the cells (typically <0.5%).
Inconsistent Incubation Times	Standardize the incubation time with the test compounds for all plates in an experiment.
Pipetting Errors	Calibrate pipettes regularly. Use reverse pipetting for viscous solutions. Ensure proper mixing of reagents.
Assay Detection Issues	Follow the ELISA or HTRF kit manufacturer's instructions carefully. Ensure proper washing steps to minimize background signal. [18]

Problem 2: Low signal or poor Z'-factor.

Possible Causes and Solutions:

Possible Cause	Troubleshooting Step
Suboptimal Cell Density	Optimize the cell seeding density to ensure sufficient A β production for detection.
Low γ -secretase Activity	Use a cell line known to have robust γ -secretase activity or one that overexpresses key components.
Insufficient Compound Potency	Use a known potent GSM as a positive control to confirm the assay is working.
Detection Reagent Issues	Check the expiration dates and storage conditions of antibodies and detection reagents. Titrate antibodies to determine the optimal concentration.
Inappropriate Assay Window	Optimize the incubation time to allow for sufficient A β accumulation.

Problem 3: Compound toxicity observed.

Possible Causes and Solutions:

Possible Cause	Troubleshooting Step
Inherent Compound Cytotoxicity	Perform a cytotoxicity assay in parallel with the GSM activity assay to determine the concentration range where the compound is not toxic.
High DMSO Concentration	Ensure the final DMSO concentration is below the toxic threshold for your cell line.
Contamination	Check for microbial contamination in the cell culture.

Quantitative Data Summary

Table 1: Typical Assay Performance Metrics

Parameter	Acceptable Range	Excellent Range
Z'-factor (Cell-Based)	0.4 - 1.0[12]	> 0.5[19]
Signal-to-Background (S/B) Ratio	> 3	> 10
Intra-assay Coefficient of Variation (%CV)	< 15%	< 10%
Inter-assay Coefficient of Variation (%CV)	< 20%	< 15%

Table 2: Example IC50 Values of Reference GSMs

Compound	Cell Line	A β 42 IC50	A β 40 Modulation
Compound E	HEK293	~5 nM[20]	Increase
DAPT	HEK293	~0.5 μ M[20]	Decrease (Inhibitor)
GSM-1	N2a-APP	~1 μ M	Increase
BPN-15606	N2a-APP	~100 nM	Increase

Note: IC50 values can vary depending on the specific cell line, assay conditions, and detection method.

Experimental Protocols

Protocol 1: Measurement of A β 42 and A β 40 Levels by Sandwich ELISA

This protocol is a general guideline and should be adapted based on the specific ELISA kit used.

- **Cell Seeding:** Seed cells (e.g., HEK293 stably expressing APP) in a 96-well plate at a pre-optimized density and allow them to adhere overnight.

- **Compound Treatment:** Prepare serial dilutions of the test compounds and a reference GSM in cell culture medium. Replace the existing medium with the compound-containing medium. Include vehicle controls (e.g., DMSO).
- **Incubation:** Incubate the plate for 24-48 hours at 37°C in a humidified incubator.
- **Sample Collection:** After incubation, carefully collect the cell culture supernatant. Centrifuge the supernatant to remove any cell debris.[21]
- **ELISA Procedure:**
 - Bring all ELISA reagents to room temperature.
 - Add standards and samples to the wells of the antibody-coated microplate.
 - Incubate as per the kit instructions (typically 1-2 hours at 37°C).
 - Wash the plate multiple times with the provided wash buffer.
 - Add the biotinylated detection antibody and incubate.
 - Wash the plate.
 - Add streptavidin-HRP conjugate and incubate.
 - Wash the plate.
 - Add the TMB substrate and incubate in the dark.
 - Add the stop solution to terminate the reaction.
- **Data Acquisition:** Read the absorbance at 450 nm using a microplate reader.
- **Data Analysis:** Generate a standard curve by plotting the absorbance of the standards against their concentrations. Calculate the concentrations of A β 42 and A β 40 in the samples and determine the A β 42/A β 40 ratio.

Protocol 2: Cytotoxicity Assay (MTT Assay)

This assay measures cell viability by assessing the metabolic activity of cells.

- **Cell Seeding and Treatment:** Follow steps 1 and 2 of the A β measurement protocol.
- **Incubation:** Incubate the plate for the same duration as the primary GSM assay.
- **MTT Addition:** Add MTT solution (3-(4,5-dimethylthiazol-2-yl)-2,5-diphenyltetrazolium bromide) to each well and incubate for 2-4 hours at 37°C.[22]
- **Formazan Solubilization:** Add a solubilization solution (e.g., DMSO or a detergent-based solution) to each well to dissolve the formazan crystals.
- **Data Acquisition:** Read the absorbance at a wavelength between 500 and 600 nm.
- **Data Analysis:** Calculate the percentage of cell viability relative to the vehicle-treated control cells.

Protocol 3: Notch Selectivity Assay (Reporter Gene Assay)

This assay determines if a compound affects Notch signaling.

- **Cell Transfection:** Co-transfect cells (e.g., H4 cells) with a human Notch Δ E expression vector and a RBP-Jk-responsive luciferase reporter construct.[23]
- **Cell Seeding and Treatment:** Seed the transfected cells in a 96-well plate and treat them with test compounds as described previously.
- **Incubation:** Incubate the plate for 16-24 hours.
- **Luciferase Assay:** Lyse the cells and measure luciferase activity using a commercial luciferase assay kit and a luminometer.
- **Data Analysis:** Normalize the luciferase signal to a co-transfected control reporter (e.g., Renilla luciferase) or to total protein concentration. Compare the signal from compound-treated cells to vehicle-treated cells to determine the effect on Notch signaling.

Visualizations

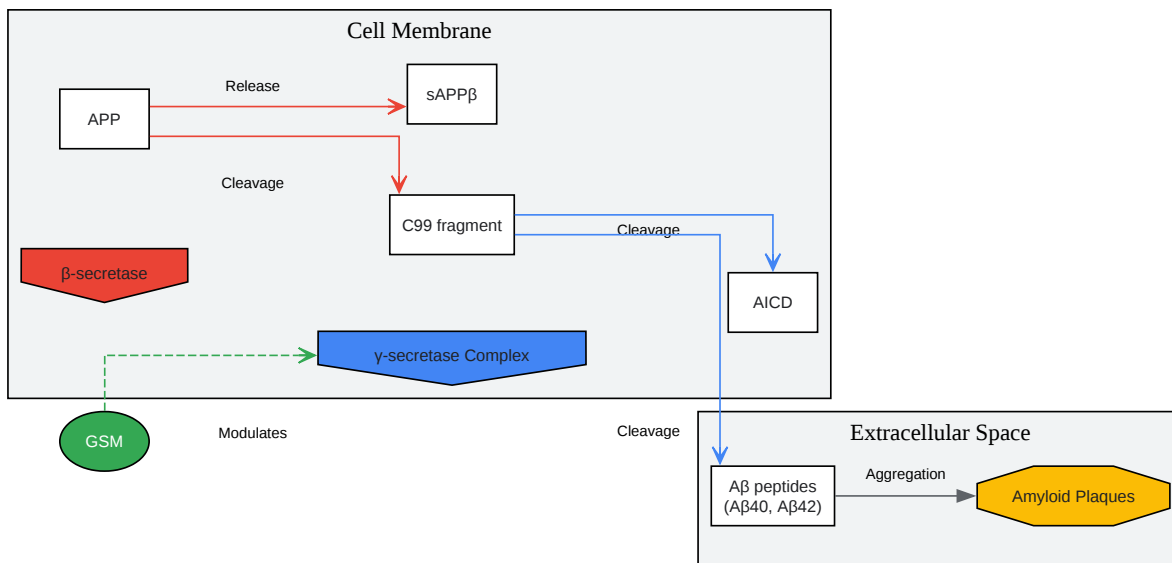

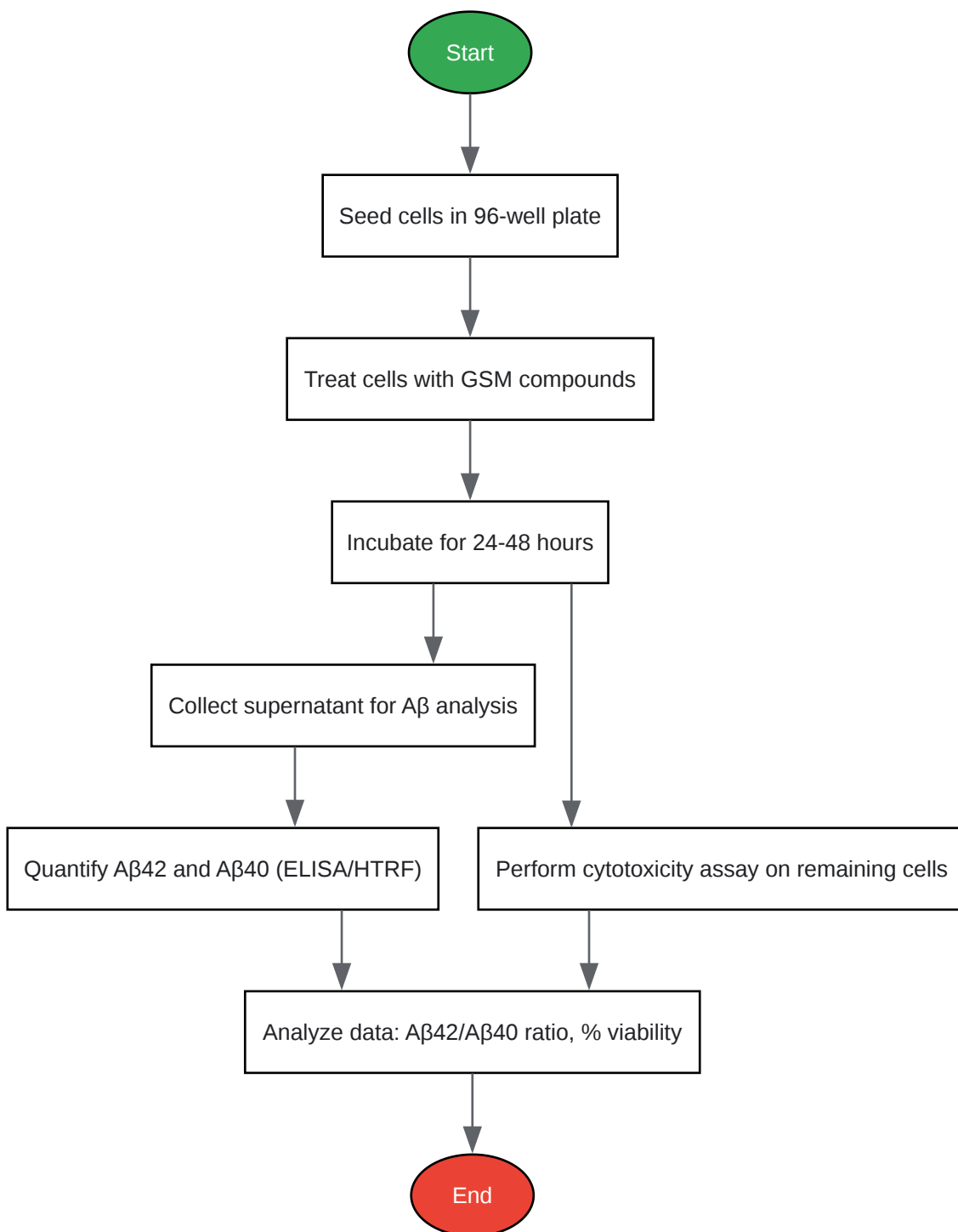

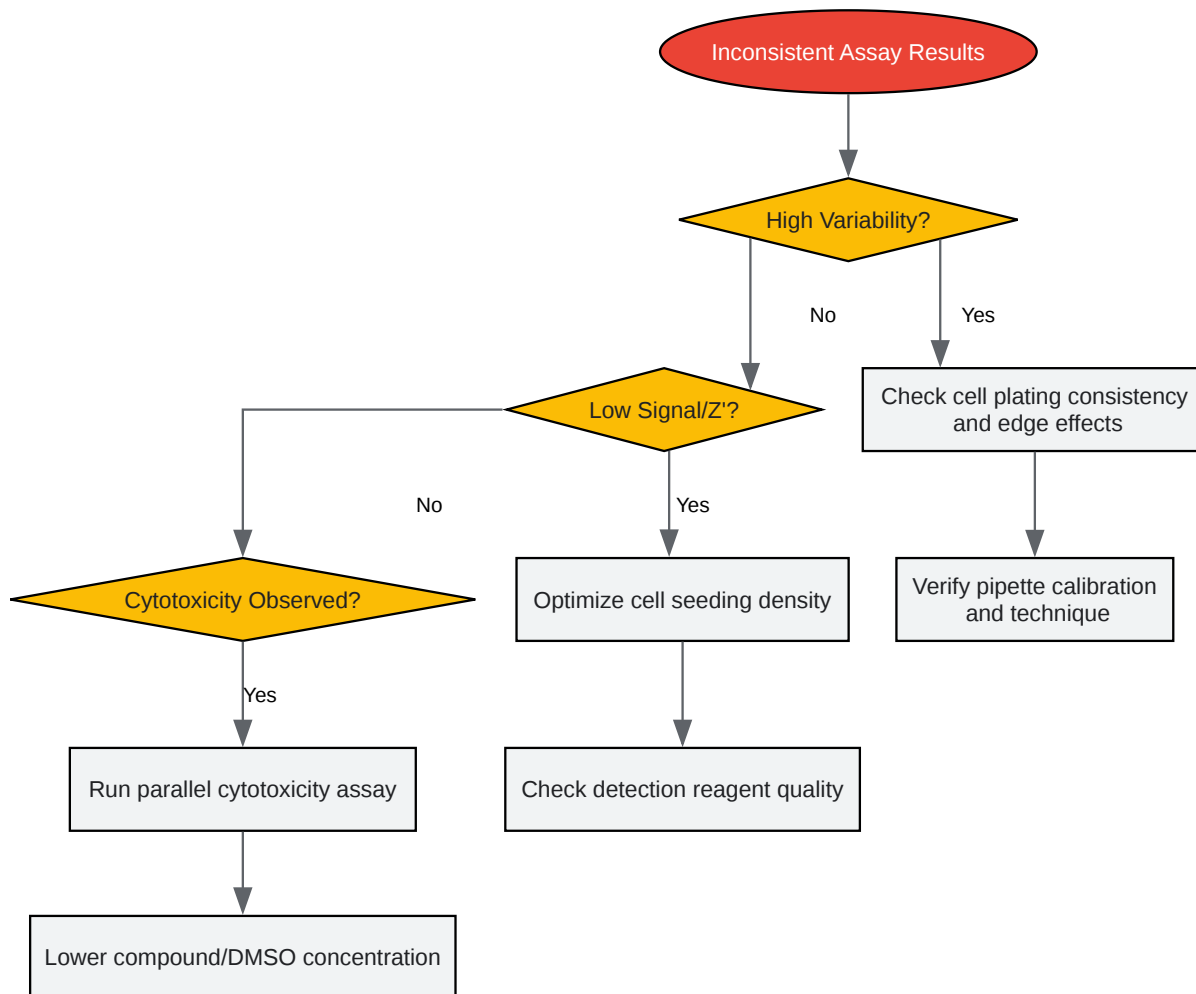

[Click to download full resolution via product page](#)

Need Custom Synthesis?

BenchChem offers custom synthesis for rare earth carbides and specific isotopic labeling.

Email: info@benchchem.com or [Request Quote Online](#).

References

- 1. Development and Mechanism of γ -Secretase Modulators for Alzheimer Disease - PMC [[pmc.ncbi.nlm.nih.gov](https://pubmed.ncbi.nlm.nih.gov/)]

- [2. \$\gamma\$ -Secretase Inhibitors and Modulators - PMC \[pmc.ncbi.nlm.nih.gov\]](#)
- [3. \$\gamma\$ -SECRETASE INHIBITORS AND MODULATORS FOR ALZHEIMER'S DISEASE - PMC \[pmc.ncbi.nlm.nih.gov\]](#)
- [4. diva-portal.org \[diva-portal.org\]](#)
- [5. Retrovectors packaged in CHO cells to generate GLP-1-Fc stable expression CHO cell lines - PMC \[pmc.ncbi.nlm.nih.gov\]](#)
- [6. Comparative Yield: HEK Cells vs. CHO Cells in Bioproduction \[cytion.com\]](#)
- [7. Development of a High-Throughput Assay for Screening of \$\gamma\$ -Secretase Inhibitor with Endogenous Human, Mouse or Drosophila \$\gamma\$ -Secretase - PMC \[pmc.ncbi.nlm.nih.gov\]](#)
- [8. New approaches for characterization of the genetic stability of vaccine cell lines - PMC \[pmc.ncbi.nlm.nih.gov\]](#)
- [9. biopharminternational.com \[biopharminternational.com\]](#)
- [10. Genetic Stability - Eurofins Scientific \[eurofins.com\]](#)
- [11. Genetic Stability Testing | Sartorius \[sartorius.com\]](#)
- [12. The Challenges In Small Molecule Drug Development – Part 3 of our Drug Discoveries Series: To Zs and Z' - Tempo Bioscience \[tempobioscience.com\]](#)
- [13. Can You Eliminate the Threats of Edge Effect During Long-term Incubation? - Advancing Cell Culture \[thermofisher.com\]](#)
- [14. Three Ways To Reduce Microplate Edge Effect | Microplate Assays \[wellplate.com\]](#)
- [15. researchgate.net \[researchgate.net\]](#)
- [16. Blog \[midsci.com\]](#)
- [17. Defeating the edge effect to consistently drive drug discovery \[thermofisher.com\]](#)
- [18. documents.thermofisher.com \[documents.thermofisher.com\]](#)
- [19. Z' Does Not Need to Be \$> 0.5\$ - PMC \[pmc.ncbi.nlm.nih.gov\]](#)
- [20. Quantification of gamma-secretase modulation differentiates inhibitor compound selectivity between two substrates Notch and amyloid precursor protein - PMC \[pmc.ncbi.nlm.nih.gov\]](#)
- [21. benchchem.com \[benchchem.com\]](#)
- [22. Cytotoxicity MTT Assay Protocols and Methods | Springer Nature Experiments \[experiments.springernature.com\]](#)
- [23. Differential Effects between \$\gamma\$ -Secretase Inhibitors and Modulators on Cognitive Function in Amyloid Precursor Protein-Transgenic and Nontransgenic Mice | Journal of Neuroscience](#)

[\[jneurosci.org\]](https://www.jneurosci.org)

- To cite this document: BenchChem. [Technical Support Center: Gamma-Secretase Modulator (GSM) Cell-Based Assays]. BenchChem, [2026]. [Online PDF]. Available at: [<https://www.benchchem.com/product/b15620104/docs#technical-support-center-gamma-secretase-modulator-gsm-cell-based-assays>]

Disclaimer & Data Validity:

The information provided in this document is for Research Use Only (RUO) and is strictly not intended for diagnostic or therapeutic procedures. While BenchChem strives to provide accurate protocols, we make no warranties, express or implied, regarding the fitness of this product for every specific experimental setup.

Technical Support: The protocols provided are for reference purposes. Unsure if this reagent suits your experiment?

Need Industrial/Bulk Grade? [Request Custom Synthesis Quote](#)

BenchChem

Our mission is to be the trusted global source of essential and advanced chemicals, empowering scientists and researchers to drive progress in science and industry.

Contact

Address: 3281 E Guasti Rd
Ontario, CA 91761, United States
Phone: (601) 213-4426
Email: info@benchchem.com

[Contact our Ph.D. Support Team for a compatibility check](#)