

Technical Support Center: Enhancing Ternary Complex Stability with AHPC-Based PROTACs

Author: BenchChem Technical Support Team. **Date:** April 2026

Compound of Interest

Compound Name: (S,R,S)-AHPC-C4-NH2
hydrochloride

Cat. No.: B15620052

[Get Quote](#)

This technical support center provides troubleshooting guidance and frequently asked questions (FAQs) for researchers and drug development professionals working with (S, R, S)-AHPC-based Proteolysis Targeting Chimeras (PROTACs). Our goal is to help you overcome common experimental challenges and enhance the stability and efficacy of your ternary complexes.

Frequently Asked Questions (FAQs)

Q1: What is a ternary complex in the context of AHPC-based PROTACs, and why is its stability important?

A1: A ternary complex is the crucial tripartite assembly of your target Protein of Interest (POI), the AHPC-based PROTAC, and the von Hippel-Lindau (VHL) E3 ubiquitin ligase.[1] The PROTAC acts as a molecular bridge, bringing the POI and VHL into close proximity.[2] The stability of this complex is paramount because it dictates the efficiency of the subsequent ubiquitination of the target protein, which marks it for degradation by the proteasome.[1][3] An unstable complex will result in poor degradation, characterized by a high half-maximal degradation concentration (DC50) and a low maximal degradation level (Dmax).[4][5]

Q2: My PROTAC shows good binary binding to both the target protein and VHL, but I'm not observing significant degradation. What could be the issue?

A2: This is a common challenge that often points to inefficient ternary complex formation.^[4] Several factors could be at play:

- **Unfavorable Geometry:** The linker connecting your target binder and the AHPC moiety may be of an inappropriate length or rigidity, leading to steric clashes between the POI and VHL, thus preventing a productive orientation for ubiquitin transfer.^{[4][6]}
- **Negative Cooperativity:** In some cases, the binding of one protein partner to the PROTAC can hinder the binding of the other, a phenomenon known as negative cooperativity ($\alpha < 1$).^[6] Ideally, you want positive cooperativity ($\alpha > 1$), where the protein-protein interactions within the ternary complex stabilize the entire assembly.^[6]
- **The "Hook Effect":** At high concentrations, your PROTAC might form more binary complexes (PROTAC-POI or PROTAC-VHL) than ternary complexes. This leads to a decrease in degradation at higher doses.^{[3][4]} Titrating your PROTAC over a wide concentration range is essential to identify the optimal window for degradation and to observe this effect.^[3]

Q3: What are the key parameters I should measure to assess the efficacy of my AHPC-based PROTAC?

A3: The efficacy of a PROTAC is primarily quantified by two parameters derived from dose-response experiments:

- **DC50 (half-maximal degradation concentration):** The concentration of your PROTAC required to degrade 50% of the target protein.^[5]
- **Dmax (maximum degradation):** The maximum percentage of protein degradation observed at the optimal PROTAC concentration.^[5]

These values are typically determined by treating cells with a range of PROTAC concentrations and quantifying the remaining target protein levels, often by Western blot.^{[2][4]}

Troubleshooting Guide

This guide addresses specific issues you may encounter during your experiments and provides actionable steps to resolve them.

Problem 1: No or Weak Target Degradation

Possible Causes:

- Poor cell permeability of the PROTAC.
- Inefficient ternary complex formation.[\[4\]](#)
- Issues with the Ubiquitin-Proteasome System (UPS) in your cell line.

Troubleshooting Steps:

- Confirm Target Engagement in Cells: First, verify that your PROTAC can bind to the target protein and VHL inside the cell. This can be assessed indirectly through control experiments.
- Run Control Experiments: Perform co-treatment experiments with inhibitors of the UPS pathway.
 - Proteasome Inhibitor Control: Pre-treat cells with a proteasome inhibitor like MG132 or bortezomib before adding your PROTAC. A reversal of degradation confirms that the protein loss is proteasome-dependent.[\[4\]](#)
 - VHL Ligand Competition: Co-treat cells with your PROTAC and an excess of a free VHL ligand (e.g., (S,R,S)-AHPC).[\[4\]](#) If degradation is rescued, it confirms that your PROTAC is working through VHL engagement.[\[4\]](#)
- Optimize PROTAC Concentration and Treatment Time: Perform a dose-response experiment with a broad range of concentrations (e.g., 1 nM to 10 μ M) and a time-course experiment (e.g., 4, 8, 16, 24 hours) to identify the optimal conditions for degradation.[\[4\]](#)
- Assess Ternary Complex Formation Directly: If you have access to the necessary equipment, use biophysical techniques to measure the formation and stability of the ternary complex in vitro.

- Surface Plasmon Resonance (SPR), Bio-Layer Interferometry (BLI), or Isothermal Titration Calorimetry (ITC): These methods can provide quantitative data on binding affinities (Kd) and cooperativity (α).^{[6][7][8]}

Problem 2: A Pronounced "Hook Effect" is Observed

Possible Cause:

- At high PROTAC concentrations, the formation of binary complexes dominates over the formation of the productive ternary complex.^{[3][6]} This is often exacerbated by poor cooperativity.

Troubleshooting Steps:

- Refine PROTAC Concentration: The "hook effect" indicates that your optimal concentration is lower than the highest concentrations tested. Narrow down the concentration range in your experiments to accurately determine the DC50 at the peak of the bell-shaped curve.^[3]
- Enhance Cooperativity:
 - Linker Optimization: The linker is a critical determinant of ternary complex geometry.^[4] Systematically vary the linker length, composition, and attachment points to the warhead and AHPC ligand. This can help to identify a linker that promotes favorable protein-protein interactions between the POI and VHL.
 - Computational Modeling: Use molecular docking and modeling to predict the structure of the ternary complex and identify potential steric clashes or opportunities for favorable interactions.^{[6][9]} This can guide the rational design of new PROTAC iterations.

Data Presentation

Table 1: Representative Efficacy Data for VHL-Recruiting PROTACs

PROTAC Example	Target Protein	DC50	Dmax	Cell Line
MZ1	BRD4	~15 nM	>90%	HeLa
ARV-110	Androgen Receptor	~1 nM	>95%	VCaP
Compound X	Target Y	>1 μ M	<20%	HEK293
Compound Z	Target Y	50 nM	~85%	HEK293

This table presents hypothetical but representative data to illustrate how to summarize key experimental outcomes.

Table 2: Recommended Concentration Ranges for Control Compounds

Control Compound	Mechanism of Action	Typical Concentration	Expected Outcome with Active PROTAC
MG132	Proteasome Inhibitor	1-10 μ M	Reversal of protein degradation
Bortezomib	Proteasome Inhibitor	10-100 nM	Reversal of protein degradation
(S,R,S)-AHPC	VHL Ligand Competitor	10-100x molar excess of PROTAC	Reversal of protein degradation
Inactive Epimer PROTAC	Fails to bind VHL	Same as active PROTAC	No protein degradation observed

Experimental Protocols

Protocol 1: Western Blot for Target Protein Degradation

This protocol is used to quantify the reduction in target protein levels following PROTAC treatment.^[4]

Methodology:

- **Cell Seeding:** Plate cells at an appropriate density in 6-well plates and allow them to adhere overnight.
- **PROTAC Treatment:** Treat cells with a serial dilution of your PROTAC (e.g., 1 nM to 10 μ M) and a vehicle control (e.g., DMSO). Incubate for a predetermined time (e.g., 16 or 24 hours).
- **Cell Lysis:** Wash cells with ice-cold PBS, then lyse with RIPA buffer containing protease and phosphatase inhibitors.
- **Protein Quantification:** Determine the protein concentration of each lysate using a BCA assay.
- **Sample Preparation:** Normalize protein concentrations and prepare samples with Laemmli buffer.
- **SDS-PAGE and Transfer:** Separate the proteins by SDS-PAGE and transfer them to a PVDF membrane.
- **Immunoblotting:**
 - Block the membrane with 5% non-fat milk or BSA in TBST for 1 hour.
 - Incubate with a primary antibody specific to the target protein and a loading control (e.g., β -actin or GAPDH) overnight at 4°C.
 - Wash the membrane and incubate with an HRP-conjugated secondary antibody for 1 hour at room temperature.
- **Data Analysis:** Acquire the chemiluminescent signal and quantify the band intensities. Normalize the target protein signal to the loading control and calculate the percentage of degradation relative to the vehicle-treated control.^[5]

Protocol 2: In-Cell Target Ubiquitination Assay

This protocol directly assesses if the target protein is ubiquitinated upon PROTAC treatment.

Methodology:

- Cell Treatment: Seed cells in 10 cm dishes. Pre-treat cells with a proteasome inhibitor (e.g., 10 μ M MG132) for 2 hours to allow ubiquitinated proteins to accumulate.[4]
- PROTAC Addition: Add your PROTAC at an effective concentration (e.g., 1-5x DC50) and a vehicle control. Incubate for 4-6 hours.
- Lysis and Immunoprecipitation (IP):
 - Lyse the cells in a non-denaturing IP buffer.
 - Incubate the lysate with an antibody against your target protein overnight.
 - Add Protein A/G beads to capture the antibody-protein complex.
 - Wash the beads extensively to remove non-specific binders.
- Elution and Western Blot Analysis:
 - Elute the protein from the beads by boiling in SDS-PAGE sample buffer.
 - Run the eluate on an SDS-PAGE gel and transfer to a membrane.
 - Probe the membrane with a primary antibody against Ubiquitin. A high-molecular-weight smear indicates poly-ubiquitination of your target protein.[4]

Visualizations

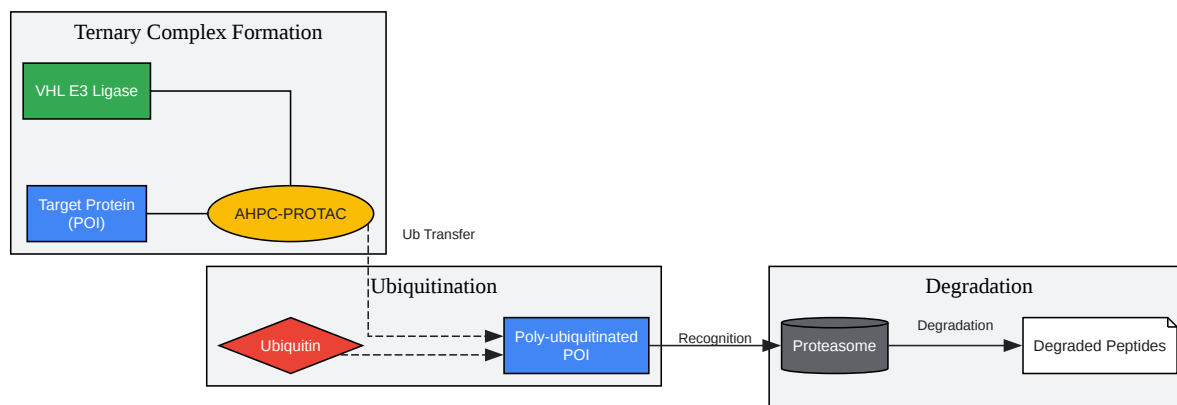

[Click to download full resolution via product page](#)

Caption: Mechanism of Action for an AHPC-based PROTAC.

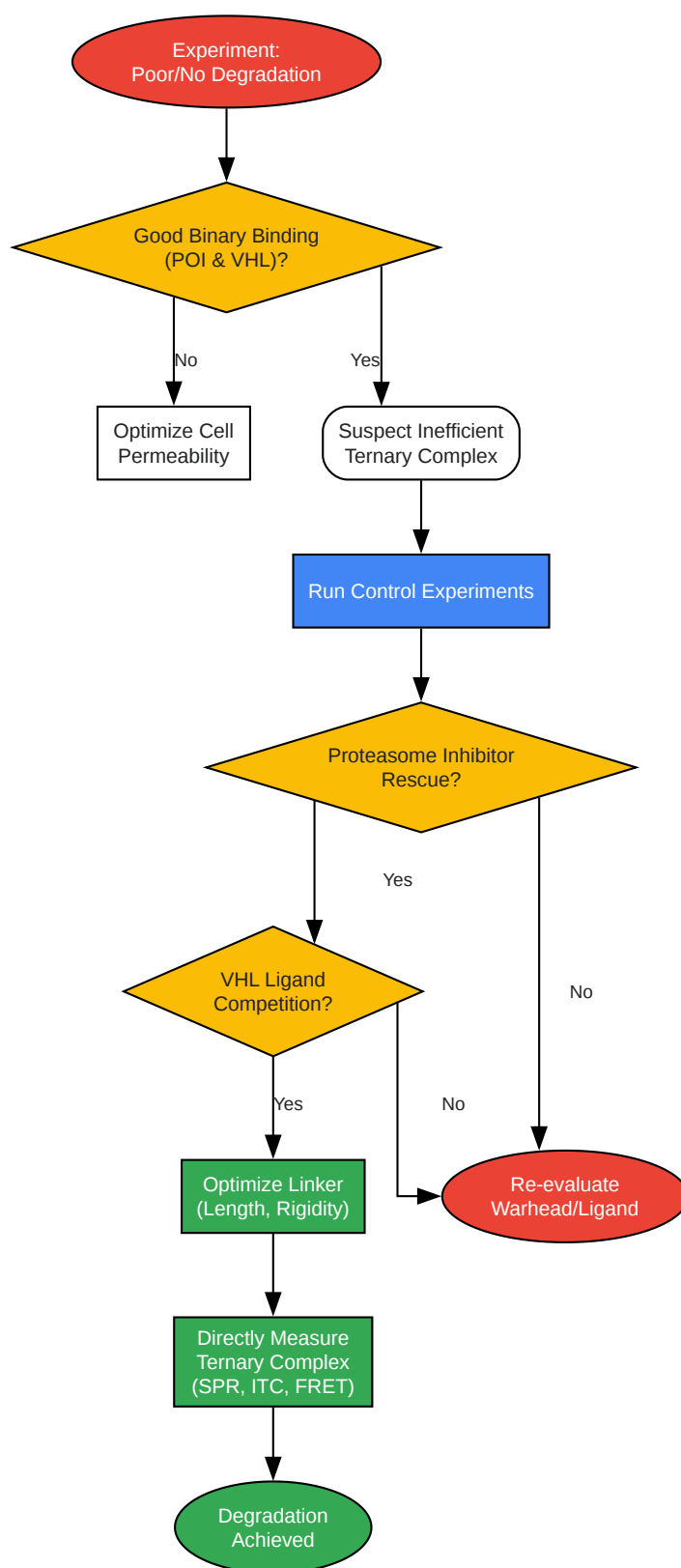

[Click to download full resolution via product page](#)

Caption: Troubleshooting workflow for failed protein degradation.

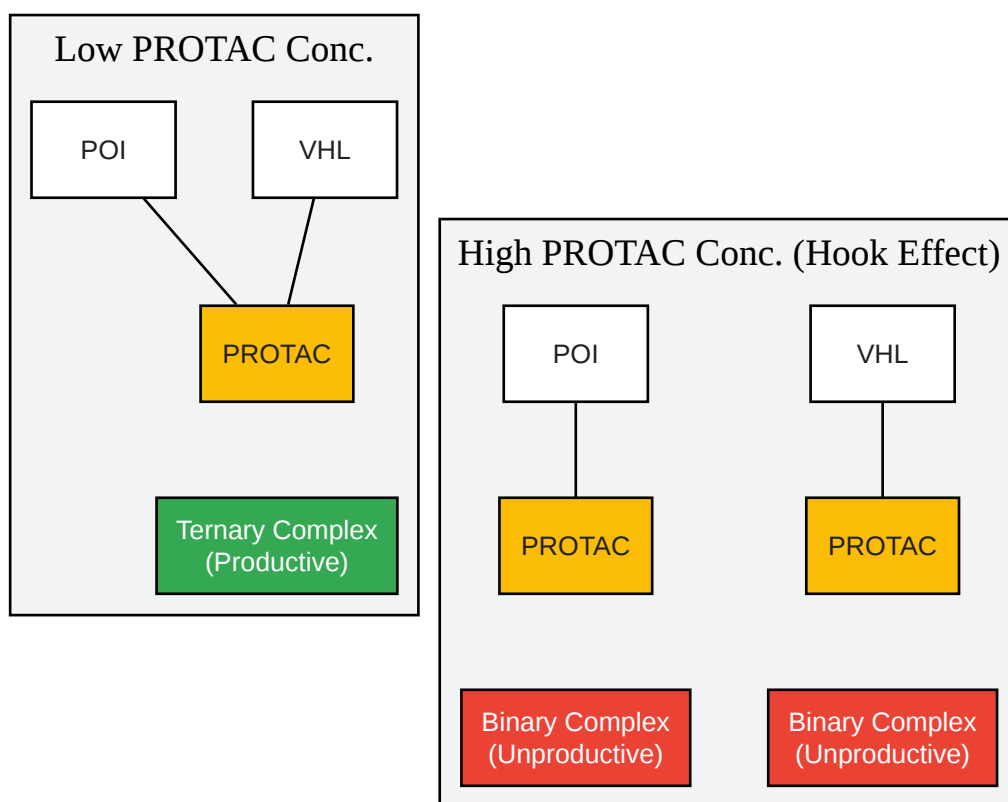

[Click to download full resolution via product page](#)

Caption: The "Hook Effect" at high PROTAC concentrations.

Need Custom Synthesis?

BenchChem offers custom synthesis for rare earth carbides and specific isotopic labeling.

Email: info@benchchem.com or [Request Quote Online](#).

References

- [1. benchchem.com \[benchchem.com\]](#)
- [2. benchchem.com \[benchchem.com\]](#)
- [3. resources.revivity.com \[resources.revivity.com\]](#)
- [4. benchchem.com \[benchchem.com\]](#)
- [5. benchchem.com \[benchchem.com\]](#)

- [6. benchchem.com \[benchchem.com\]](https://www.benchchem.com)
- [7. Biophysical Approaches for Investigating the Dynamics and Cooperativity of Ternary Complexes in Targeted Protein Degradation - PubMed \[pubmed.ncbi.nlm.nih.gov\]](#)
- [8. The Development and Application of Biophysical Assays for Evaluating Ternary Complex Formation Induced by Proteolysis Targeting Chimeras \(PROTACS\) - PubMed \[pubmed.ncbi.nlm.nih.gov\]](#)
- [9. DSpace \[diposit.ub.edu\]](https://diposit.ub.edu)
- To cite this document: BenchChem. [Technical Support Center: Enhancing Ternary Complex Stability with AHPC-Based PROTACs]. BenchChem, [2026]. [Online PDF]. Available at: [\[https://www.benchchem.com/product/b15620052/docs#technical-support-center-enhancing-ternary-complex-stability-with-ahpc-based-protacs\]](https://www.benchchem.com/product/b15620052/docs#technical-support-center-enhancing-ternary-complex-stability-with-ahpc-based-protacs)

Disclaimer & Data Validity:

The information provided in this document is for Research Use Only (RUO) and is strictly not intended for diagnostic or therapeutic procedures. While BenchChem strives to provide accurate protocols, we make no warranties, express or implied, regarding the fitness of this product for every specific experimental setup.

Technical Support: The protocols provided are for reference purposes. Unsure if this reagent suits your experiment?

Need Industrial/Bulk Grade? [Request Custom Synthesis Quote](#)

BenchChem

Our mission is to be the trusted global source of essential and advanced chemicals, empowering scientists and researchers to drive progress in science and industry.

Contact

Address: 3281 E Guasti Rd
Ontario, CA 91761, United States
Phone: (601) 213-4426
Email: info@benchchem.com

Contact our Ph.D. Support Team for a compatibility check