

Investigating the Downstream Effects of Estrogen Receptor Ligands: A Technical Guide

Author: BenchChem Technical Support Team. **Date:** April 2026

Compound of Interest

Compound Name: *ER ligand-6*

Cat. No.: *B15620076*

[Get Quote](#)

Disclaimer: The specified "**ER ligand-6**" is not a recognized molecule in publicly available scientific literature. This guide utilizes Tamoxifen, a well-characterized Selective Estrogen Receptor Modulator (SERM), as a representative compound to illustrate the experimental investigation of the downstream effects of a novel estrogen receptor (ER) ligand. The data and methodologies presented are based on published findings for Tamoxifen and serve as a template for the analysis of new chemical entities targeting the estrogen receptor.

Introduction

Estrogen receptors (ER α and ER β) are ligand-activated transcription factors that play a pivotal role in various physiological processes and are implicated in the pathology of numerous diseases, most notably breast cancer.[1] The modulation of ER activity by small molecule ligands is a cornerstone of endocrine therapy. Understanding the downstream effects of a novel ER ligand is critical for its development as a therapeutic agent. This technical guide provides a comprehensive overview of the core methodologies and data analysis required to characterize the biological activity of a putative ER ligand, using Tamoxifen as a model.

Quantitative Data Summary

The biological effects of an ER ligand can be quantified through various in vitro assays. The following tables summarize representative data for Tamoxifen, providing a benchmark for the evaluation of a novel compound.

Table 1: Estrogen Receptor Binding Affinity of Tamoxifen and its Metabolites

This table presents the relative binding affinities (RBA) and dissociation constants (Kd) of Tamoxifen and its active metabolite, 4-hydroxytamoxifen, for the estrogen receptor alpha (ER α).

Compound	Receptor	IC50 (nM)	Kd (nM)	Relative Binding Affinity (%) (Estradiol = 100)
Tamoxifen	ER α	~50	~1.7[2]	2-4[3]
4-hydroxytamoxifen	ER α	~1	~0.06	100-200[3]

IC50 and Kd values can vary based on experimental conditions.

Table 2: Cytotoxicity of Tamoxifen in Human Breast Cancer Cell Lines

The half-maximal inhibitory concentration (IC50) is a measure of the potency of a compound in inhibiting a specific biological or biochemical function. This table shows the IC50 values of Tamoxifen in various breast cancer cell lines after 72 hours of treatment.

Cell Line	ER Status	IC50 (µM)
MCF-7	Positive	10.05[4]
T47D	Positive	~15-20
MDA-MB-231	Negative	21.8[5]
HCC1937	Negative	4.58[4]

IC50 values are highly dependent on the assay conditions, such as cell density and incubation time.

Table 3: Effect of Tamoxifen on ER Target Gene Expression in MCF-7 Cells

This table illustrates the modulatory effect of Tamoxifen on the expression of well-established estrogen-responsive genes.

Gene	Function	Treatment (10 nM 4-OH-Tamoxifen)	Fold Change vs. Control
TFF1 (pS2)	Growth factor	Antagonist	Downregulated
PGR	Progesterone Receptor	Antagonist	Downregulated
GREB1	Estrogen-regulated growth	Antagonist	Downregulated[6]

The effect of a SERM on gene expression can be tissue- and context-dependent.

Signaling Pathways

ER ligands can elicit their effects through both genomic and non-genomic signaling pathways. The classical genomic pathway involves the direct binding of the ER-ligand complex to DNA, while non-genomic pathways involve the rapid activation of cytoplasmic signaling cascades.

Genomic Estrogen Receptor Signaling

The canonical pathway involves the binding of the ligand to ER in the cytoplasm, leading to its dimerization, nuclear translocation, and binding to Estrogen Response Elements (EREs) in the promoter regions of target genes, thereby modulating their transcription.

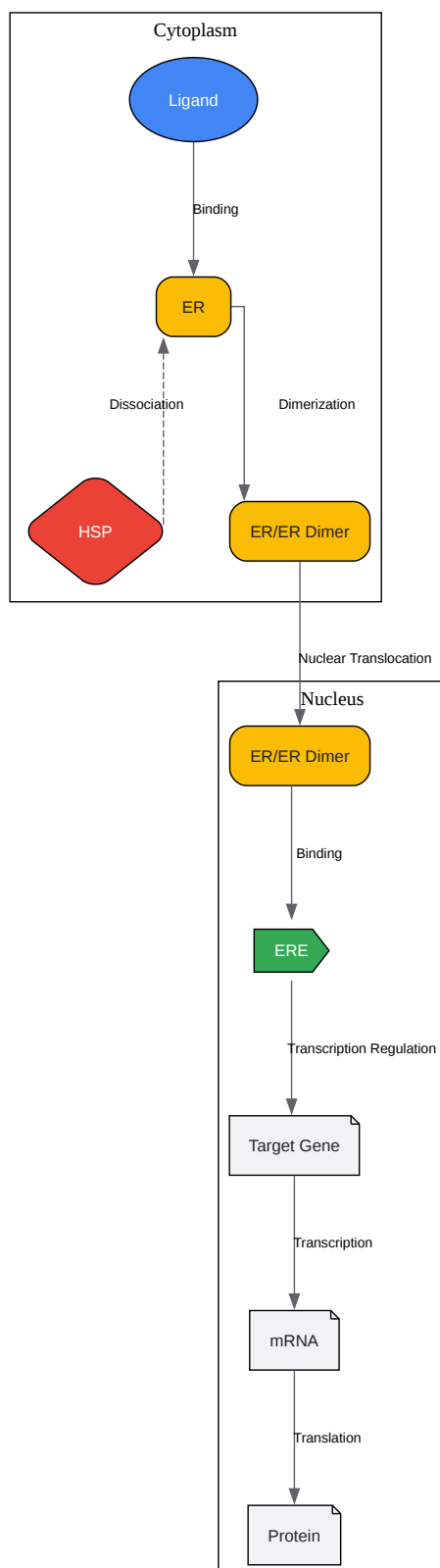

[Click to download full resolution via product page](#)

Genomic ER Signaling Pathway.

Non-Genomic Estrogen Receptor Signaling

A fraction of ER resides at the cell membrane and can initiate rapid, non-genomic signaling cascades, such as the PI3K/AKT and MAPK/ERK pathways, which can in turn influence cell survival and proliferation.[7]

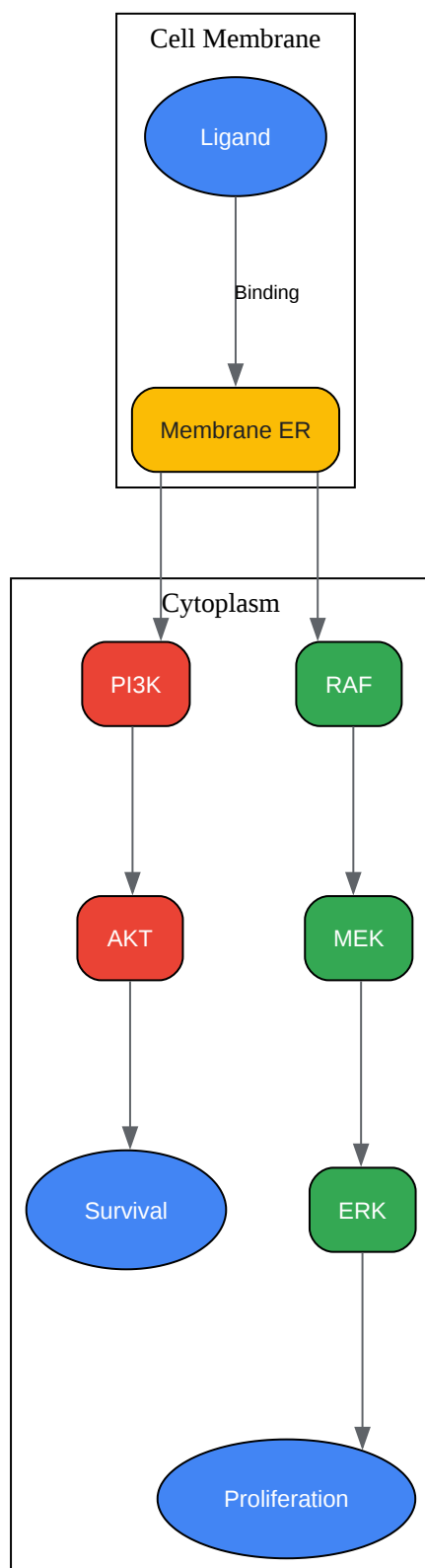

[Click to download full resolution via product page](#)

Non-Genomic ER Signaling Pathways.

Experimental Protocols

Detailed methodologies for the key experiments cited in this guide are provided below.

Estrogen Receptor Competitive Binding Assay

This assay determines the ability of a test compound to compete with radiolabeled estradiol for binding to the estrogen receptor.

Materials:

- Rat uterine cytosol (source of ER)
- [³H]-17β-estradiol (radiolabeled ligand)
- Test compound (e.g., **ER ligand-6**)
- Assay buffer (TEDG: 10 mM Tris, 1.5 mM EDTA, 1 mM dithiothreitol, 10% glycerol, pH 7.4)
- Hydroxylapatite (HAP) slurry
- Scintillation fluid and counter

Procedure:

- Prepare serial dilutions of the test compound and a standard (unlabeled 17β-estradiol).
- In assay tubes, combine a fixed amount of rat uterine cytosol, a fixed concentration of [³H]-17β-estradiol, and varying concentrations of the test compound or standard.
- Include tubes for total binding (no competitor) and non-specific binding (a high concentration of unlabeled estradiol).
- Incubate the tubes overnight at 4°C to reach equilibrium.
- Add HAP slurry to each tube to separate bound from free radioligand.
- Wash the HAP pellets to remove unbound radioligand.

- Add scintillation fluid to the pellets and measure radioactivity using a scintillation counter.
- Calculate the percentage of specific binding at each concentration of the test compound and determine the IC50 value.[\[8\]](#)

MTT Cell Viability Assay

This colorimetric assay measures the metabolic activity of cells as an indicator of cell viability.

Materials:

- Human breast cancer cell lines (e.g., MCF-7, T47D, MDA-MB-231)
- Cell culture medium and supplements
- Test compound
- MTT (3-(4,5-dimethylthiazol-2-yl)-2,5-diphenyltetrazolium bromide) solution (5 mg/mL in PBS)
- Solubilization solution (e.g., DMSO or a solution of 0.2% NP-40 and 8 mM HCl in isopropanol)
- 96-well plates
- Microplate reader

Procedure:

- Seed cells in a 96-well plate at a predetermined density and allow them to adhere overnight.
- Treat the cells with serial dilutions of the test compound for the desired duration (e.g., 72 hours).
- Add MTT solution to each well and incubate for 3-4 hours at 37°C, allowing viable cells to reduce the MTT to formazan crystals.
- Remove the medium and add the solubilization solution to dissolve the formazan crystals.

- Measure the absorbance at a wavelength of 570-590 nm using a microplate reader.
- Calculate the percentage of cell viability relative to untreated control cells and determine the IC50 value.[\[9\]](#)[\[10\]](#)

Quantitative Real-Time PCR (qPCR)

qPCR is used to measure the relative expression levels of target genes.

Materials:

- Treated cells
- RNA extraction kit
- Reverse transcription kit
- qPCR master mix (e.g., SYBR Green)
- Gene-specific primers for target genes (e.g., TFF1, PGR, GREB1) and a reference gene (e.g., GAPDH, ACTB)
- qPCR instrument

Procedure:

- Lyse the treated cells and extract total RNA using a commercial kit.
- Assess RNA quality and quantity.
- Synthesize complementary DNA (cDNA) from the RNA using a reverse transcription kit.
- Set up the qPCR reactions containing cDNA, qPCR master mix, and gene-specific primers.
- Run the qPCR reaction in a real-time PCR instrument.
- Analyze the data using the comparative Ct ($\Delta\Delta C_t$) method to determine the relative fold change in gene expression, normalized to the reference gene.[\[11\]](#)[\[12\]](#)

Western Blot Analysis

Western blotting is used to detect specific proteins and assess their expression and phosphorylation status.

Materials:

- Treated cells
- Lysis buffer with protease and phosphatase inhibitors
- Protein quantification assay (e.g., BCA assay)
- SDS-PAGE gels and running buffer
- Transfer apparatus and buffer
- PVDF or nitrocellulose membrane
- Blocking buffer (e.g., 5% non-fat milk or BSA in TBST)
- Primary antibodies (e.g., anti-p-AKT, anti-total-AKT, anti-p-ERK, anti-total-ERK, anti- β -actin)
- HRP-conjugated secondary antibodies
- Chemiluminescent substrate
- Imaging system

Procedure:

- Lyse the treated cells and quantify the protein concentration.
- Separate the proteins by size using SDS-PAGE.
- Transfer the separated proteins to a membrane.
- Block the membrane to prevent non-specific antibody binding.

- Incubate the membrane with a primary antibody specific to the target protein overnight at 4°C.
- Wash the membrane and incubate with an HRP-conjugated secondary antibody.
- Wash the membrane again and add a chemiluminescent substrate.
- Capture the signal using an imaging system and perform densitometric analysis to quantify protein levels, normalizing to a loading control like β -actin.[13][14]

Experimental Workflow

The following diagram illustrates a typical workflow for the initial characterization of a novel ER ligand.

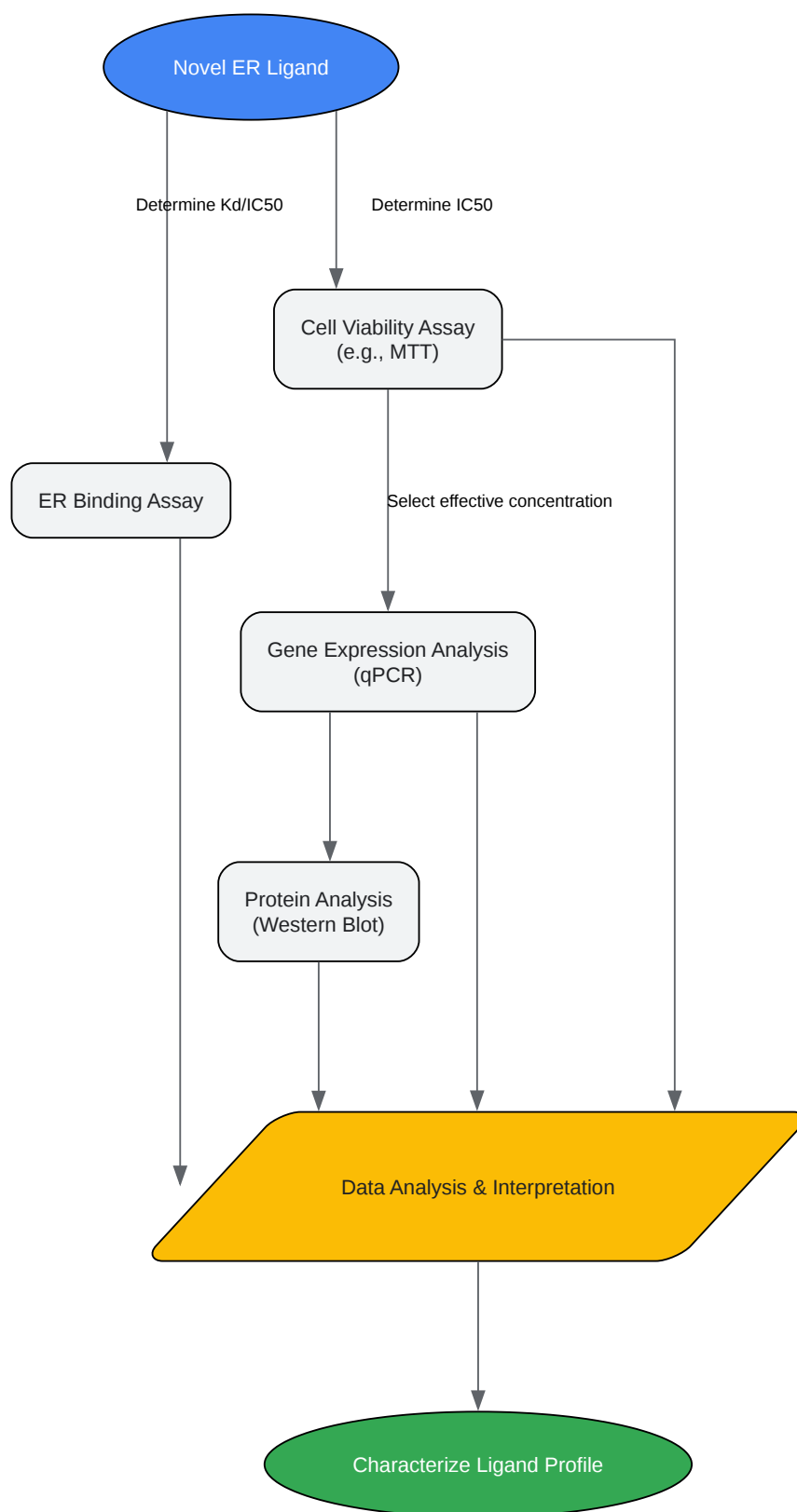

[Click to download full resolution via product page](#)

Workflow for ER Ligand Characterization.

This comprehensive approach, combining binding, functional, and signaling assays, will provide a robust characterization of the downstream effects of a novel estrogen receptor ligand, enabling informed decisions for further drug development.

Need Custom Synthesis?

BenchChem offers custom synthesis for rare earth carbides and specific isotopic labeling.

Email: info@benchchem.com or [Request Quote Online](#).

References

- [1. Western Blot Protocol | Proteintech Group \[ptglab.com\]](#)
- [2. Phospho-ERK Assays - Assay Guidance Manual - NCBI Bookshelf \[ncbi.nlm.nih.gov\]](#)
- [3. Frontiers | Development of a novel cell-based, In-Cell Western/ERK assay system for the high-throughput screening of agonists acting on the delta-opioid receptor \[frontiersin.org\]](#)
- [4. benchchem.com \[benchchem.com\]](#)
- [5. idtdna.com \[idtdna.com\]](#)
- [6. creative-diagnostics.com \[creative-diagnostics.com\]](#)
- [7. Western blot protocol | Abcam \[abcam.com\]](#)
- [8. ntp.niehs.nih.gov \[ntp.niehs.nih.gov\]](#)
- [9. researchhub.com \[researchhub.com\]](#)
- [10. merckmillipore.com \[merckmillipore.com\]](#)
- [11. stackscientific.nd.edu \[stackscientific.nd.edu\]](#)
- [12. 定量PCR基础知识 \[sigmaaldrich.com\]](#)
- [13. benchchem.com \[benchchem.com\]](#)
- [14. Western Blot Protocol | Proteintech Group \[ptglab.com\]](#)
- To cite this document: BenchChem. [Investigating the Downstream Effects of Estrogen Receptor Ligands: A Technical Guide]. BenchChem, [2026]. [Online PDF]. Available at: [<https://www.benchchem.com/product/b15620076/docs#investigating-the-downstream-effects-of-estrogen-receptor-ligands-a-technical-guide>]

Disclaimer & Data Validity:

The information provided in this document is for Research Use Only (RUO) and is strictly not intended for diagnostic or therapeutic procedures. While BenchChem strives to provide accurate protocols, we make no warranties, express or implied, regarding the fitness of this product for every specific experimental setup.

Technical Support: The protocols provided are for reference purposes. Unsure if this reagent suits your experiment?

Need Industrial/Bulk Grade? [Request Custom Synthesis Quote](#)

BenchChem

Our mission is to be the trusted global source of essential and advanced chemicals, empowering scientists and researchers to drive progress in science and industry.

Contact

Address: 3281 E Guasti Rd
Ontario, CA 91761, United States
Phone: (601) 213-4426
Email: info@benchchem.com

[Contact our Ph.D. Support Team for a compatibility check](#)