

CHMFL-PI4K-127: A Comparative Guide to its On-Target Activity

Author: BenchChem Technical Support Team. **Date:** April 2026

Compound of Interest

Compound Name: CHMFL-PI4K-127

Cat. No.: B15620493

[Get Quote](#)

For Researchers, Scientists, and Drug Development Professionals

This guide provides a comprehensive comparison of **CHMFL-PI4K-127**, a potent inhibitor of Plasmodium falciparum phosphatidylinositol 4-kinase (PfPI4K), with other known PI4K inhibitors. The information presented herein is supported by experimental data to offer an objective analysis of its on-target activity, selectivity, and cellular efficacy.

On-Target Potency and Cellular Efficacy

CHMFL-PI4K-127 demonstrates exceptional potency against its intended target, PfPI4K, with a half-maximal inhibitory concentration (IC₅₀) in the nanomolar range. This high biochemical potency translates to effective inhibition of parasite growth in cellular assays.

Compound	Target	Biochemical IC50 (nM)	Cellular EC50 (nM)	Reference
CHMFL-PI4K-127	PfPI4K	0.9	25.1 (P. falciparum 3D7 strain)	[1][2]
MMV390048	PfPI4K	-	-	[3][4]
UCT943	PfPI4K	-	-	[5]
KDU691	Plasmodium PI4K	-	-	[6]

Note: Direct comparison of IC50 and EC50 values should be made with caution as they may be determined using different experimental protocols.

CHMFL-PI4K-127 has been shown to be highly selective for PfPI4K over human lipid and protein kinases, a critical attribute for minimizing off-target effects and potential toxicity.[1][2][7] The structural differences between the ATP-binding sites of PfPI4K and human PI4K isoforms are thought to be the basis for this selectivity.[5][8][9]

Comparative Analysis with Alternative PI4K Inhibitors

A number of other inhibitors targeting PI4K have been developed, primarily for anti-malarial and anti-viral applications. The following table summarizes the activity of some of these compounds.

Inhibitor	Target(s)	Biochemical IC50 (nM)	Notes
MMV390048	Plasmodium PI4K	-	First PfPI4K inhibitor to enter clinical trials. [3]
UCT943	Plasmodium PI4K	-	Optimized from the 2-aminopyridine series to improve solubility and potency.[5]
KDU691	Plasmodium PI4K	-	Active against liver-stage hypnozoites.[6]
GSK-A1	PI4KA	~3 (cellular IC50)	Selective inhibitor of human PI4KIII α .

Experimental Protocols

The determination of on-target activity and selectivity of PI4K inhibitors involves a combination of biochemical and cell-based assays.

Biochemical Kinase Activity Assays

1. ADP-Glo™ Kinase Assay:

This luminescent assay quantifies the amount of ADP produced during the kinase reaction.

- Principle: The assay is performed in two steps. First, the kinase reaction is stopped, and the remaining ATP is depleted. Second, the ADP is converted to ATP, which is then used in a luciferase/luciferin reaction to generate a light signal that is proportional to the ADP concentration.
- Procedure:
 - Recombinant PI4K enzyme is incubated with the lipid substrate (phosphatidylinositol) and ATP in the presence of varying concentrations of the inhibitor.

- After incubation, ADP-Glo™ Reagent is added to terminate the kinase reaction and deplete the remaining ATP.
- Kinase Detection Reagent is then added to convert ADP to ATP and generate a luminescent signal.
- Luminescence is measured using a plate reader.
- IC50 values are calculated by plotting the luminescence signal against the inhibitor concentration.

2. Competitive ELISA:

This assay measures the amount of the kinase product, phosphatidylinositol 4-phosphate (PI4P).

- Principle: This is a competitive enzyme-linked immunosorbent assay where the signal is inversely proportional to the amount of PI4P produced.
- Procedure:
 - The PI4K enzymatic reaction is performed as described above.
 - The reaction is stopped, and a PI4P detector protein is added.
 - This mixture is transferred to a plate pre-coated with a PI4P-binding protein.
 - The detector protein competes with the plate-bound protein for binding to the PI4P produced in the reaction.
 - A secondary antibody conjugated to an enzyme (e.g., HRP) is added, followed by a chromogenic substrate.
 - The absorbance is measured, and the amount of PI4P is quantified, from which the inhibitor's potency is determined.

Cell-Based Assays

1. P. falciparum Growth Inhibition Assay:

This assay measures the ability of a compound to inhibit the growth of malaria parasites in red blood cells.

- Principle: Parasite growth is assessed by measuring the incorporation of a fluorescent dye, such as SYBR Green I, which binds to parasitic DNA.
- Procedure:
 - Synchronized P. falciparum-infected red blood cells are incubated with serial dilutions of the test compound for a full parasite life cycle (e.g., 72 hours).
 - After incubation, the cells are lysed, and SYBR Green I dye is added.
 - Fluorescence is measured to quantify the amount of parasitic DNA, which is proportional to parasite growth.
 - EC50 values are determined by plotting fluorescence against inhibitor concentration.

Kinase Selectivity Profiling

Kinobeads™ Technology:

This chemical proteomics approach is used to determine the selectivity of a kinase inhibitor against a broad panel of kinases.

- Principle: A cell lysate is incubated with the inhibitor of interest at various concentrations. The mixture is then passed over beads coupled with a broad-spectrum kinase inhibitor (kinobeads). Kinases that are not bound by the test inhibitor will bind to the beads. By quantifying the amount of each kinase that binds to the beads at different inhibitor concentrations, the binding affinity (and thus selectivity) can be determined.
- Procedure:
 - Cell lysates are pre-incubated with different concentrations of the test inhibitor or a DMSO control.

- The lysates are then incubated with the kinobeads to capture unbound kinases.
- The beads are washed, and the bound proteins are eluted and identified and quantified using mass spectrometry.
- The degree of competition between the test inhibitor and the kinobeads for each kinase is used to determine the inhibitor's selectivity profile.

Visualizing Key Processes

To better understand the context of **CHMFL-PI4K-127**'s activity, the following diagrams illustrate the PI4K signaling pathway and a general workflow for kinase inhibitor profiling.

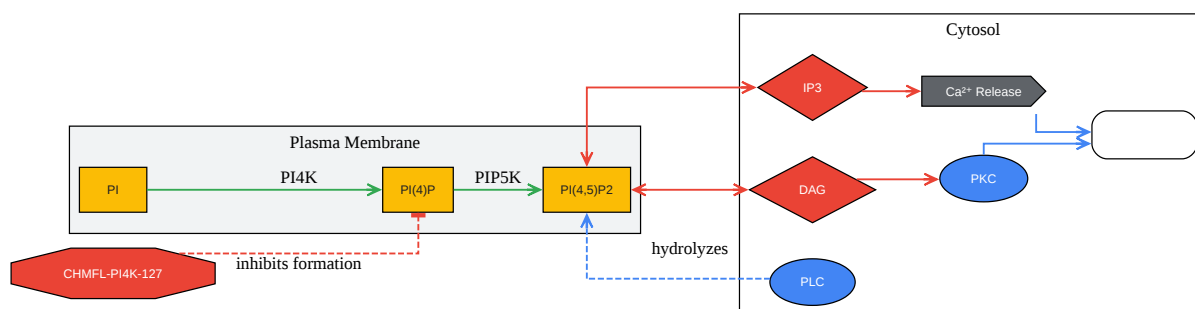

[Click to download full resolution via product page](#)

Caption: Simplified PI4K signaling pathway and the inhibitory action of **CHMFL-PI4K-127**.

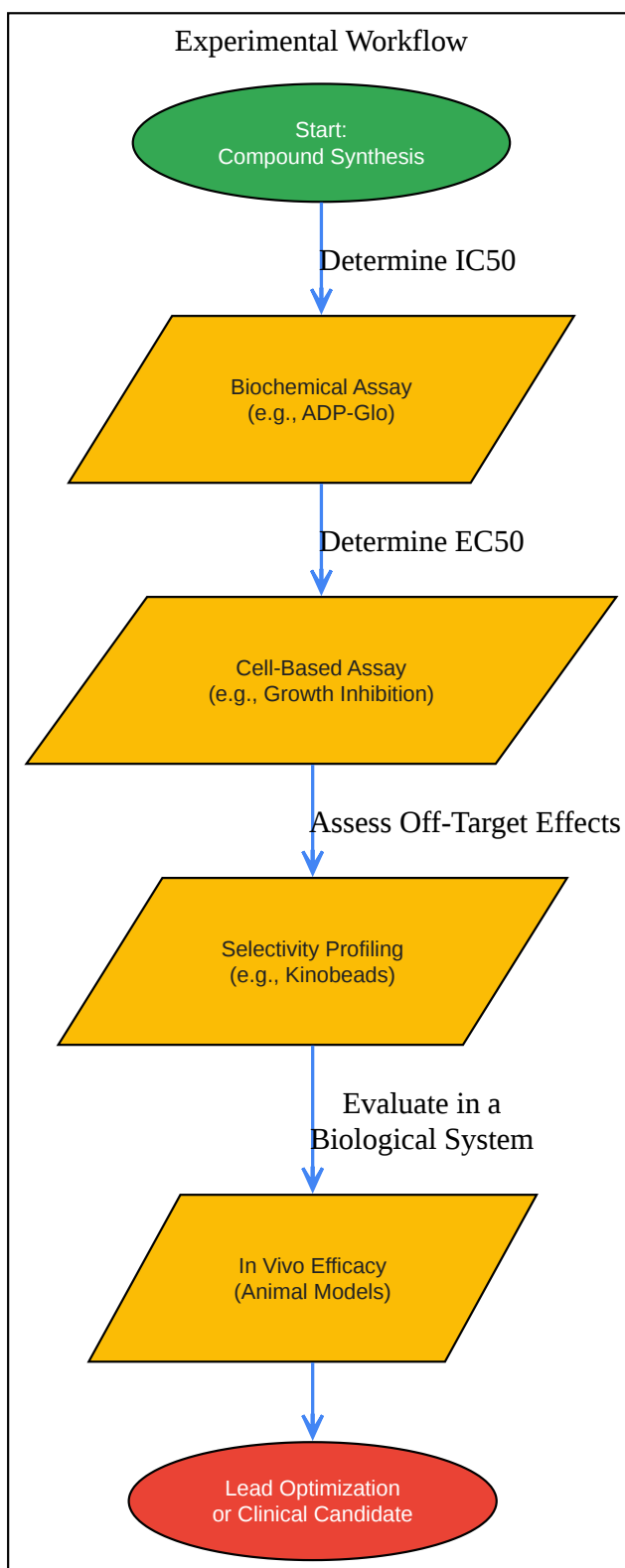

[Click to download full resolution via product page](#)

Caption: A general experimental workflow for kinase inhibitor profiling.

Need Custom Synthesis?

BenchChem offers custom synthesis for rare earth carbides and specific isotopic labeling.

Email: info@benchchem.com or [Request Quote Online](#).

References

- 1. Scientists Discover Novel Kinase Inhibitor Against Plasmodium---High Magnetic Field Laboratory, Chinese Academy of Sciences [english.hmfl.cas.cn]
- 2. Discovery of 6'-chloro-N-methyl-5'-(phenylsulfonamido)-[3,3'-bipyridine]-5-carboxamide (CHMFL-PI4K-127) as a novel Plasmodium falciparum PI(4)K inhibitor with potent antimalarial activity against both blood and liver stages of Plasmodium - PubMed [pubmed.ncbi.nlm.nih.gov]
- 3. researchgate.net [researchgate.net]
- 4. Antimalarial efficacy of MMV390048, an inhibitor of Plasmodium phosphatidylinositol 4-kinase - PMC [pmc.ncbi.nlm.nih.gov]
- 5. researchgate.net [researchgate.net]
- 6. Targeting Plasmodium phosphatidylinositol 4-kinase to eliminate malaria - PMC [pmc.ncbi.nlm.nih.gov]
- 7. medchemexpress.com [medchemexpress.com]
- 8. Structural Basis for Inhibitor Potency and Selectivity of Plasmodium falciparum Phosphatidylinositol 4-Kinase Inhibitors - PubMed [pubmed.ncbi.nlm.nih.gov]
- 9. pubs.acs.org [pubs.acs.org]
- To cite this document: BenchChem. [CHMFL-PI4K-127: A Comparative Guide to its On-Target Activity]. BenchChem, [2026]. [Online PDF]. Available at: [https://www.benchchem.com/product/b15620493/docs#chmfl-pi4k-127-a-comparative-guide-to-its-on-target-activity]

Disclaimer & Data Validity:

The information provided in this document is for Research Use Only (RUO) and is strictly not intended for diagnostic or therapeutic procedures. While BenchChem strives to provide

accurate protocols, we make no warranties, express or implied, regarding the fitness of this product for every specific experimental setup.

Technical Support: The protocols provided are for reference purposes. Unsure if this reagent suits your experiment?

Need Industrial/Bulk Grade? [Request Custom Synthesis Quote](#)

BenchChem

Our mission is to be the trusted global source of essential and advanced chemicals, empowering scientists and researchers to drive progress in science and industry.

Contact

Address: 3281 E Guasti Rd

Ontario, CA 91761, United States

Phone: (601) 213-4426

Email: info@benchchem.com

[Contact our Ph.D. Support Team for a compatibility check](#)