

# "CDK7 ligand 2" binding affinity and kinetics

**Author:** BenchChem Technical Support Team. **Date:** April 2026

## Compound of Interest

Compound Name: CDK7 ligand 2

Cat. No.: B15620224

[Get Quote](#)

An In-depth Technical Guide on the Binding Affinity and Kinetics of a Representative CDK7 Ligand: THZ1

## Introduction

Cyclin-dependent kinase 7 (CDK7) is a crucial enzyme that plays a dual role in regulating the cell cycle and gene transcription.<sup>[1][2]</sup> It acts as a CDK-activating kinase (CAK), phosphorylating other CDKs to control cell cycle progression, and as a component of the general transcription factor TFIIH, where it phosphorylates the C-terminal domain (CTD) of RNA Polymerase II (Pol II) to initiate transcription.<sup>[2][3][4]</sup> Given its central role in processes frequently deregulated in cancer, CDK7 has emerged as a significant target for therapeutic intervention.

The term "**CDK7 ligand 2**" is often used to describe a chemical moiety for building PROteolysis Targeting Chimeras (PROTACs) and does not refer to a single, well-characterized molecule with extensive public data. This guide, therefore, focuses on THZ1, a potent and selective covalent inhibitor of CDK7, as a representative ligand to provide researchers, scientists, and drug development professionals with a detailed understanding of the principles and methodologies for characterizing such compounds.<sup>[5][6][7]</sup> THZ1 achieves its high potency and selectivity by forming an irreversible covalent bond with a unique cysteine residue (Cys312) located near the ATP-binding pocket of CDK7.<sup>[3][5][6]</sup>

## Binding Affinity and Kinetics

The interaction of THZ1 with CDK7 is characterized by high affinity and a covalent, irreversible binding mechanism. This leads to sustained and potent inhibition of the kinase's activity.

### Quantitative Binding Affinity Data

The affinity of THZ1 for CDK7 has been determined using various biochemical assays. The half-maximal inhibitory concentration (IC50) and dissociation constant (Kd) values highlight its potency.

Parameter	Value (nM)	Assay Type	Target Complex	Reference(s)
IC50	3.2	In Vitro Kinase Assay	Recombinant CDK7	[1][5][6][7]
Kd	3.2	LanthaScreen® Eu Kinase Binding Assay	Recombinant CDK7	[8]
Cellular IC50	0.55 - 101.2	Cell Viability/Proliferation Assays	Varies by cell line (e.g., Jurkat, Loucy, NALM6)	[6][9]

### Binding Kinetics and Covalent Inhibition

THZ1's mechanism involves time-dependent, irreversible inhibition, a hallmark of covalent inhibitors. Its acrylamide moiety forms a permanent bond with Cys312 of CDK7.[3]

Parameter	Description	Evidence/Value	Reference(s)
Mechanism	Covalent, Irreversible	Forms a covalent bond with Cysteine 312 (Cys312) on CDK7.	[3][4][10]
Time-Dependence	Inhibitory activity increases with longer pre-incubation times before ATP addition.	Confirmed via LanthaScreen® and in vitro kinase assays.	[11][12]
Kinetic Rate (k <sub>inact</sub> )	A related, faster-acting inhibitor (YKL-5-124) has a k <sub>inact</sub> of 103 μM <sup>-1</sup> s <sup>-1</sup> , compared to ~9 μM <sup>-1</sup> s <sup>-1</sup> for THZ1, providing a kinetic benchmark.	Comparative kinetic analysis.	[13]
Irreversibility	Inhibition is sustained even after the compound is removed from the surrounding medium.	Demonstrated in cellular washout experiments.	[12]

## Experimental Protocols

The following protocols provide detailed methodologies for characterizing the binding affinity and kinetics of covalent CDK7 inhibitors like THZ1.

### In Vitro Kinase Inhibition Assay (IC<sub>50</sub> Determination)

This assay directly measures the enzymatic activity of CDK7 in the presence of an inhibitor.

- Objective: To determine the concentration of the inhibitor required to reduce CDK7 kinase activity by 50%.
- Materials:

- Recombinant human CDK7/Cyclin H/MAT1 complex.[4]
- Kinase Buffer (e.g., 50 mM HEPES pH 7.5, 10 mM MgCl<sub>2</sub>, 1 mM EGTA, 2 mM DTT, 0.01% Tween-20).[4]
- ATP solution.
- Substrate: A peptide derived from the RNA Polymerase II CTD.[4][10]
- THZ1 (or test compound) serially diluted in DMSO.
- Detection Reagent: ADP-Glo™ Kinase Assay kit, which measures ADP production as a proxy for kinase activity.[4]
- 384-well plates.
- Procedure:
  - Prepare serial dilutions of THZ1 in DMSO.
  - In a 384-well plate, add the kinase buffer, the diluted THZ1, and the CDK7 enzyme solution.
  - To assess time-dependent inhibition, pre-incubate the enzyme and inhibitor mixture for a defined period (e.g., 60 minutes) at room temperature.[11]
  - Initiate the kinase reaction by adding the substrate/ATP solution. The final ATP concentration should be close to its Michaelis constant (K<sub>m</sub>) for CDK7.[4][10]
  - Allow the reaction to proceed for a set time (e.g., 1 hour) at 30°C.[4]
  - Stop the reaction and add the ADP-Glo™ detection reagents according to the manufacturer's protocol.
  - Measure the resulting luminescence using a plate reader.
  - Calculate the percent inhibition for each THZ1 concentration relative to a DMSO vehicle control and fit the data to a dose-response curve to determine the IC<sub>50</sub> value.[4]

## LanthaScreen® Eu Kinase Binding Assay (Kd Determination)

This assay measures the binding affinity of the inhibitor to the kinase directly.

- Objective: To determine the dissociation constant (Kd) and confirm time-dependent binding.
- Methodology: This is a proprietary time-resolved fluorescence resonance energy transfer (TR-FRET) assay. It involves a europium-labeled anti-tag antibody that binds to the kinase and a fluorescently labeled ATP-competitive tracer that binds to the kinase's active site. An inhibitor will displace the tracer, leading to a decrease in the FRET signal.
- Procedure:
  - The recombinant CDK7 complex is incubated with the Eu-labeled antibody, the fluorescent tracer, and varying concentrations of THZ1.[\[12\]](#)
  - To demonstrate time-dependence, measurements are taken at multiple time points (e.g., 20, 60, and 180 minutes).[\[11\]](#)[\[12\]](#)
  - The TR-FRET signal is read on a compatible plate reader.
  - The data is used to calculate the affinity (Kd) of THZ1 for CDK7. A decrease in the apparent affinity over time is indicative of covalent bond formation.[\[12\]](#)

## Cellular Washout Assay (Confirmation of Irreversibility)

This experiment is crucial for demonstrating that an inhibitor binds irreversibly within a cellular context.

- Objective: To assess whether the inhibition of CDK7's downstream signaling is sustained after the removal of the inhibitor.
- Procedure:
  - Culture cells (e.g., Jurkat T-ALL cells) and treat them with a potent concentration of THZ1 or a DMSO control for a sufficient duration (e.g., 4 hours) to ensure target engagement.  
[\[12\]](#)

- Washout Step: Remove the inhibitor-containing medium, wash the cells multiple times with fresh, pre-warmed medium to remove any unbound compound.
- Resuspend the cells in fresh, inhibitor-free medium.
- Collect cell samples at various time points post-washout (e.g., 0, 2, 4, 6 hours).[12]
- Prepare cell lysates and perform Western blotting to analyze the phosphorylation status of CDK7 substrates, such as Serine 5 on the RNAPII CTD.[12]
- Sustained suppression of RNAPII phosphorylation at later time points, long after the compound has been washed away, confirms irreversible inhibition.[12]

## Visualizations

Diagrams are essential for illustrating the complex biological pathways and experimental procedures involved in CDK7 inhibitor characterization.

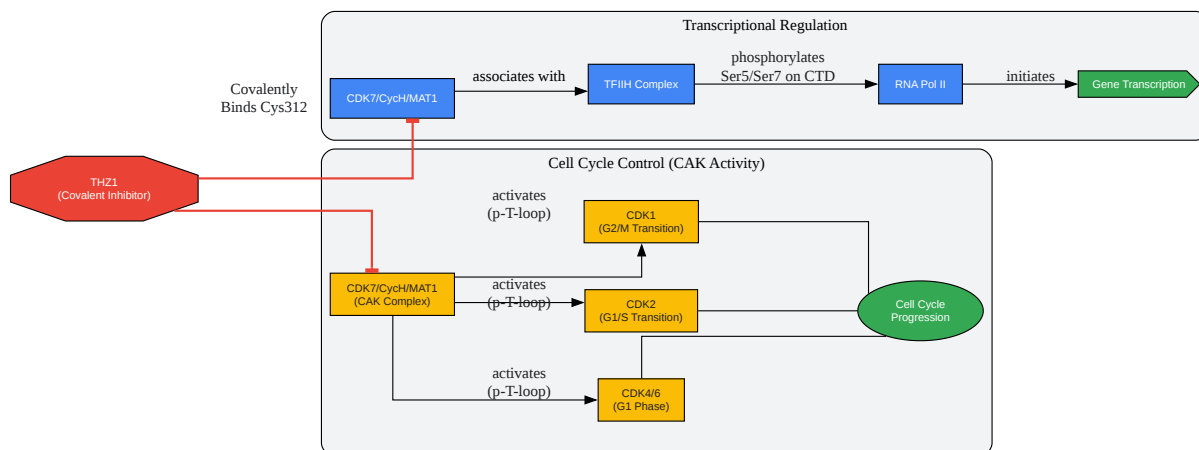

[Click to download full resolution via product page](#)

**Caption:** Dual roles of CDK7 in transcription and cell cycle, and its inhibition by THZ1.

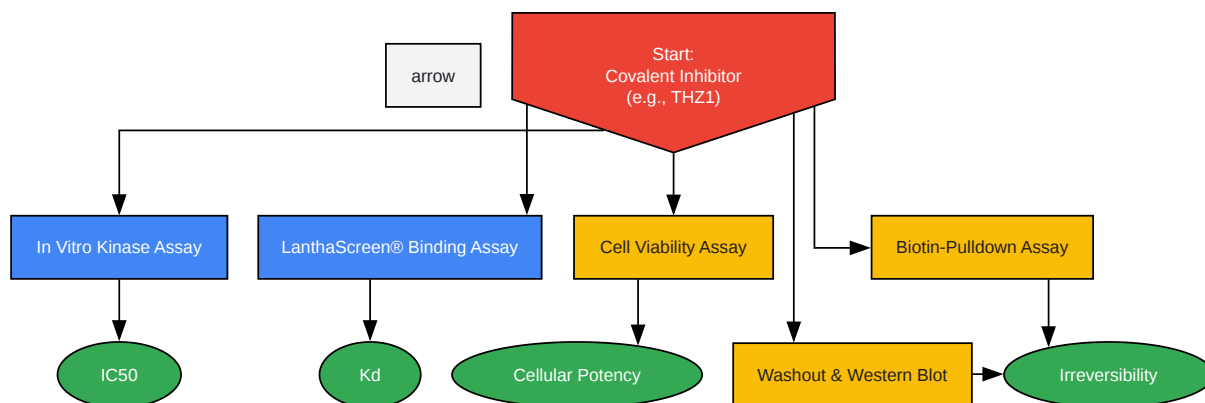

[Click to download full resolution via product page](#)

**Caption:** Workflow for characterizing a covalent CDK7 inhibitor like THZ1.

### Need Custom Synthesis?

BenchChem offers custom synthesis for rare earth carbides and specific isotopic labeling.

Email: [info@benchchem.com](mailto:info@benchchem.com) or [Request Quote Online](#).

## References

- 1. Identification of CDK7 Inhibitors from Natural Sources Using Pharmacoinformatics and Molecular Dynamics Simulations - PMC [[pmc.ncbi.nlm.nih.gov](https://pubmed.ncbi.nlm.nih.gov/)]
- 2. Cyclin-dependent kinase 7 - Wikipedia [[en.wikipedia.org](https://en.wikipedia.org/)]
- 3. [benchchem.com](https://www.benchchem.com/) [[benchchem.com](https://www.benchchem.com/)]
- 4. [benchchem.com](https://www.benchchem.com/) [[benchchem.com](https://www.benchchem.com/)]
- 5. THZ1 | CDK | TargetMol [[targetmol.com](https://www.targetmol.com/)]
- 6. [apexbt.com](https://www.apexbt.com/) [[apexbt.com](https://www.apexbt.com/)]
- 7. [medchemexpress.com](https://www.medchemexpress.com/) [[medchemexpress.com](https://www.medchemexpress.com/)]
- 8. Probe THZ1 | Chemical Probes Portal [[chemicalprobes.org](https://www.chemicalprobes.org/)]

- [9. Frontiers | CDK7 Inhibitor THZ1 Induces the Cell Apoptosis of B-Cell Acute Lymphocytic Leukemia by Perturbing Cellular Metabolism \[frontiersin.org\]](#)
- [10. benchchem.com \[benchchem.com\]](#)
- [11. benchchem.com \[benchchem.com\]](#)
- [12. Targeting transcription regulation in cancer with a covalent CDK7 inhibitor - PMC \[pmc.ncbi.nlm.nih.gov\]](#)
- [13. Development of a selective CDK7 covalent inhibitor reveals predominant cell cycle phenotype - PMC \[pmc.ncbi.nlm.nih.gov\]](#)
- To cite this document: BenchChem. ["CDK7 ligand 2" binding affinity and kinetics]. BenchChem, [2026]. [Online PDF]. Available at: [\[https://www.benchchem.com/product/b15620224/docs#cdk7-ligand-2-binding-affinity-and-kinetics\]](https://www.benchchem.com/product/b15620224/docs#cdk7-ligand-2-binding-affinity-and-kinetics)

---

#### Disclaimer & Data Validity:

The information provided in this document is for Research Use Only (RUO) and is strictly not intended for diagnostic or therapeutic procedures. While BenchChem strives to provide accurate protocols, we make no warranties, express or implied, regarding the fitness of this product for every specific experimental setup.

**Technical Support:** The protocols provided are for reference purposes. Unsure if this reagent suits your experiment?

**Need Industrial/Bulk Grade?** [Request Custom Synthesis Quote](#)

## BenchChem

Our mission is to be the trusted global source of essential and advanced chemicals, empowering scientists and researchers to drive progress in science and industry.

#### Contact

Address: 3281 E Guasti Rd  
Ontario, CA 91761, United States  
Phone: (601) 213-4426  
Email: [info@benchchem.com](mailto:info@benchchem.com)

Contact our Ph.D. Support Team for a compatibility check