

Application Notes and Protocols: Biotin-PEG3-C3-NH2 Reaction with Carboxylic Acids

Author: BenchChem Technical Support Team. **Date:** December 2025

Compound of Interest

Compound Name: *Biotin-PEG3-C3-NH2*

Cat. No.: *B15620072*

[Get Quote](#)

For Researchers, Scientists, and Drug Development Professionals

Introduction

Biotinylation, the process of covalently attaching biotin to a molecule, is a cornerstone technique in biotechnology, enabling a wide range of applications from immunoassays and affinity purification to targeted drug delivery.[1] The exceptional affinity between biotin and streptavidin ($K_a = 10^{15} \text{ M}^{-1}$) provides a highly specific and robust system for the detection, isolation, and study of biomolecules.[1][2]

This document provides detailed application notes and protocols for the reaction of **Biotin-PEG3-C3-NH2** with molecules containing carboxylic acids, such as proteins, peptides, and nanoparticles.[3] This biotinylation reagent features a primary amine group that can be covalently linked to carboxyl groups (-COOH) on aspartic acid, glutamic acid residues, or the C-terminus of a polypeptide chain.[1] The reaction is efficiently mediated by the carbodiimide crosslinker 1-Ethyl-3-(3-dimethylaminopropyl)carbodiimide (EDC), often in conjunction with N-hydroxysuccinimide (NHS) or its water-soluble analog, Sulfo-NHS, to enhance coupling efficiency and stability.[1][4]

The incorporated polyethylene glycol (PEG) spacer in **Biotin-PEG3-C3-NH2** offers several advantages, including increased aqueous solubility and reduced steric hindrance, which facilitates efficient binding of the biotin moiety to avidin or streptavidin.[5][6]

Principle of the Reaction

The conjugation of **Biotin-PEG3-C3-NH2** to a carboxylic acid is a two-step process facilitated by EDC and NHS (or Sulfo-NHS).

- **Activation of Carboxylic Acid:** EDC activates the carboxyl groups on the target molecule to form a highly reactive O-acylisourea intermediate.[1] This intermediate is unstable in aqueous solutions and susceptible to hydrolysis.[7]
- **Formation of a Stable Intermediate:** To improve the efficiency and stability of the reaction, NHS or Sulfo-NHS is added. It reacts with the O-acylisourea intermediate to form a more stable, amine-reactive NHS ester.[4] This NHS ester is less prone to hydrolysis.[7]
- **Amide Bond Formation:** The primary amine of the **Biotin-PEG3-C3-NH2** molecule then performs a nucleophilic attack on the NHS ester, resulting in the formation of a stable amide bond and covalently linking the biotin moiety to the target molecule.[1]

The inclusion of NHS or Sulfo-NHS in the reaction mixture increases the overall efficiency of the conjugation and minimizes undesirable side reactions, such as protein-protein polymerization.[1][8]

Core Reaction Pathway

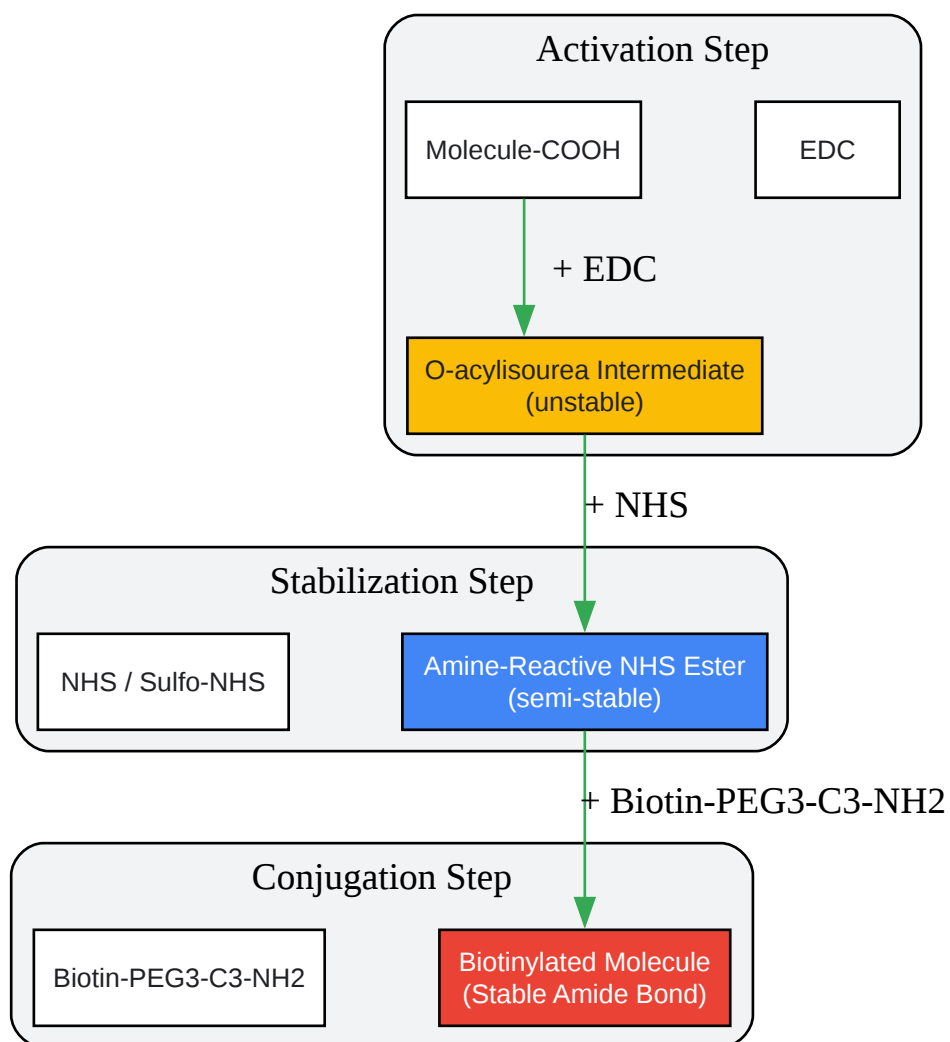

[Click to download full resolution via product page](#)

Caption: EDC/NHS mediated biotinylation of a carboxylic acid.

Quantitative Data and Reaction Parameters

The efficiency of the biotinylation reaction is dependent on several factors, including pH, temperature, and the molar ratios of the reactants. The following tables provide recommended starting conditions that may require further optimization for specific applications.

Table 1: Recommended pH for Reaction Steps

Reaction Step	Optimal pH Range	Recommended Buffer	Rationale
Carboxylic Acid Activation	4.7 - 6.0	MES Buffer	EDC/NHS chemistry is most efficient at a slightly acidic pH for the activation of carboxyl groups.[1][7]
Amine Coupling	7.0 - 8.0	PBS or Bicarbonate Buffer	The primary amine of Biotin-PEG3-C3-NH2 is more nucleophilic at a neutral to slightly basic pH, promoting efficient coupling to the NHS ester.[3][9]

Table 2: Recommended Molar Ratios of Reactants

Reactants	Recommended Molar Ratio	Notes
Molecule : EDC : NHS	1 : 40 : 100 to 1 : 200 : 500	A significant molar excess of EDC and NHS over the number of carboxyl groups is typically required to drive the reaction.[3]
Molecule : Biotin-PEG3-C3-NH2	1 : 20 to 1 : 100	The optimal ratio depends on the desired degree of labeling. A higher ratio increases biotin incorporation but may also impact the function of the target molecule.[3]

Experimental Protocols

Materials and Reagents

- Molecule to be labeled (e.g., protein, peptide) with available carboxyl groups.
- **Biotin-PEG3-C3-NH2**
- 1-Ethyl-3-(3-dimethylaminopropyl)carbodiimide (EDC)
- N-hydroxysuccinimide (NHS) or N-hydroxysulfosuccinimide (Sulfo-NHS)
- Activation Buffer: 0.1 M MES (2-(N-morpholino)ethanesulfonic acid), pH 4.7-6.0.[1] Crucially, avoid buffers containing primary amines (e.g., Tris, glycine) or carboxylates (e.g., acetate). [10][11]
- Coupling Buffer: Phosphate-Buffered Saline (PBS), pH 7.2-8.0.[3]
- Quenching Solution (Optional): 1 M Tris-HCl, pH 8.0 or 1 M Glycine.
- Desalting column or dialysis cassette for purification.
- Anhydrous Dimethylsulfoxide (DMSO) or Dimethylformamide (DMF) for preparing stock solutions.

Preparation of Stock Solutions

- Molecule Solution: Prepare the molecule to be labeled at a concentration of 1-5 mg/mL in cold Activation Buffer.[3]
- **Biotin-PEG3-C3-NH2** Stock: Dissolve **Biotin-PEG3-C3-NH2** in DMSO or DMF to create a 10-50 mM stock solution.[3]
- EDC Stock (Prepare Fresh): Immediately before use, dissolve EDC in cold Activation Buffer to a concentration of 10 mg/mL (~52 mM).[3]
- NHS/Sulfo-NHS Stock (Prepare Fresh): Immediately before use, dissolve NHS or Sulfo-NHS in cold Activation Buffer to a concentration of 10 mg/mL (~87 mM for NHS).[3]

Two-Step Biotinylation Protocol

This protocol is a general guideline and may require optimization for your specific molecule.

- Activation of Carboxylic Acids:
 - To your molecule solution in Activation Buffer, add the freshly prepared EDC and NHS/Sulfo-NHS stock solutions. A common starting point is a 40-fold molar excess of EDC and a 100-fold molar excess of NHS over the molecule.[\[3\]](#)
 - Incubate for 15-30 minutes at room temperature with gentle mixing.[\[1\]](#)
- Conjugation with **Biotin-PEG3-C3-NH2**:
 - If a desalting column was not used to remove excess EDC/NHS, adjust the reaction pH to 7.2-8.0 by adding Coupling Buffer or a dilute base.[\[3\]](#)
 - Add the calculated amount of **Biotin-PEG3-C3-NH2** stock solution to the activated molecule solution. A 20- to 50-fold molar excess of the biotin reagent over the molecule is a good starting point.[\[1\]](#)
 - Incubate for 2 hours at room temperature or overnight at 4°C with gentle mixing.[\[1\]](#)[\[3\]](#)
- Quenching (Optional):
 - To stop the reaction, add a quenching solution (e.g., Tris or glycine) to a final concentration of 10-50 mM.[\[3\]](#)
 - Incubate for 15 minutes at room temperature. This step will consume any unreacted NHS esters.[\[3\]](#)
- Purification:
 - Remove excess, non-reacted **Biotin-PEG3-C3-NH2** and byproducts using a desalting column or dialysis against an appropriate buffer (e.g., PBS).[\[12\]](#)

Experimental Workflow

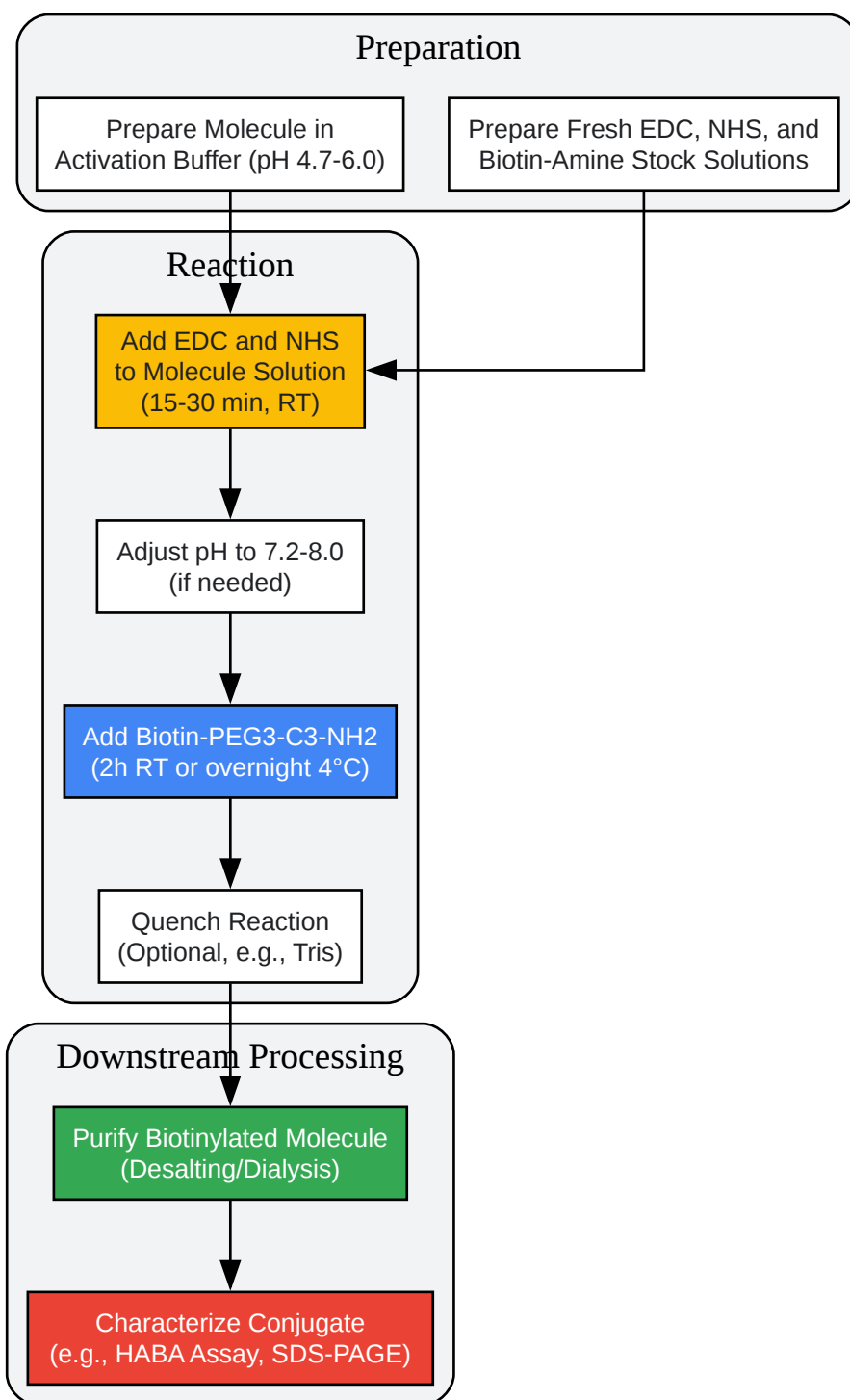

[Click to download full resolution via product page](#)

Caption: General workflow for biotinylation of carboxylic acids.

Troubleshooting

Issue	Potential Cause	Suggested Solution
Low Labeling Efficiency	Inefficient activation of carboxyl groups.	Ensure the pH of the Activation Buffer is between 4.7 and 6.0. Use freshly prepared EDC and NHS solutions.[7][9]
Hydrolysis of NHS ester.	Perform the conjugation step immediately after activation. Ensure the pH for the coupling reaction is not too high (ideally 7.2-8.0).[9]	
Presence of amine-containing buffers.	Use amine-free buffers such as MES and PBS for the reaction.[10][11]	
Protein Precipitation	High concentration of organic solvent from stock solutions.	Ensure the final concentration of DMSO or DMF is below 10% of the total reaction volume.[9]
Protein polymerization.	Use a two-step protocol and consider removing excess EDC and NHS before adding the biotin-amine. A large molar excess of the biotin reagent can also help to outcompete protein-protein crosslinking. [12]	

Applications

The biotinylation of molecules via their carboxyl groups using **Biotin-PEG3-C3-NH2** is a versatile technique with numerous applications in research and drug development, including:

- Immunoassays: Development of detection reagents for ELISA, Western blotting, and immunohistochemistry.[1]

- Affinity Purification: Immobilization of proteins or other molecules onto streptavidin-coated surfaces for pull-down assays and the identification of binding partners.[5]
- PROTAC Development: **Biotin-PEG3-C3-NH2** can serve as a linker in the synthesis of Proteolysis Targeting Chimeras (PROTACs), where the biotin moiety can be used for in vitro studies and purification.[5]
- Cell Surface Labeling: Biotinylation of surface-exposed proteins on living cells for their subsequent isolation and analysis.[13] Carboxyl-reactive biotinylation can be more selective and efficient than amine-reactive methods for this purpose.[13]

By following the detailed protocols and considering the key parameters outlined in these application notes, researchers can successfully employ **Biotin-PEG3-C3-NH2** for the efficient and specific biotinylation of carboxylic acid-containing molecules to advance their scientific investigations.

Need Custom Synthesis?

BenchChem offers custom synthesis for rare earth carbides and specific isotopic labeling.

Email: info@benchchem.com or [Request Quote Online](#).

References

- 1. benchchem.com [benchchem.com]
- 2. Bioconjugation application notes [bionordika.fi]
- 3. benchchem.com [benchchem.com]
- 4. Carbodiimide Crosslinker Chemistry | Thermo Fisher Scientific - HK [thermofisher.com]
- 5. benchchem.com [benchchem.com]
- 6. Biotin-PEG3-amine, 359860-27-8 | BroadPharm [broadpharm.com]
- 7. benchchem.com [benchchem.com]
- 8. General Protocol for Coupling Biomolecules to Carboxylate Particles using EDC/Sulfo-NHS [echobiosystems.com]
- 9. benchchem.com [benchchem.com]

- 10. Biotinylation - Wikipedia [en.wikipedia.org]
- 11. Biotinylation | Thermo Fisher Scientific - US [thermofisher.com]
- 12. documents.thermofisher.com [documents.thermofisher.com]
- 13. pubs.acs.org [pubs.acs.org]
- To cite this document: BenchChem. [Application Notes and Protocols: Biotin-PEG3-C3-NH2 Reaction with Carboxylic Acids]. BenchChem, [2025]. [Online PDF]. Available at: [https://www.benchchem.com/product/b15620072#biotin-peg3-c3-nh2-reaction-with-carboxylic-acids]

Disclaimer & Data Validity:

The information provided in this document is for Research Use Only (RUO) and is strictly not intended for diagnostic or therapeutic procedures. While BenchChem strives to provide accurate protocols, we make no warranties, express or implied, regarding the fitness of this product for every specific experimental setup.

Technical Support: The protocols provided are for reference purposes. Unsure if this reagent suits your experiment? [[Contact our Ph.D. Support Team for a compatibility check](#)]

Need Industrial/Bulk Grade? [Request Custom Synthesis Quote](#)

BenchChem

Our mission is to be the trusted global source of essential and advanced chemicals, empowering scientists and researchers to drive progress in science and industry.

Contact

Address: 3281 E Guasti Rd

Ontario, CA 91761, United States

Phone: (601) 213-4426

Email: info@benchchem.com