

common issues with AM-6494 stability in long-term studies

Author: BenchChem Technical Support Team. **Date:** April 2026

Compound of Interest

Compound Name: AM-6494

Cat. No.: B15619981

[Get Quote](#)

AM-6494 Technical Support Center

Disclaimer: This technical support center provides generalized guidance on the handling and stability of the BACE1 inhibitor, **AM-6494**. As extensive long-term stability data for **AM-6494** is not publicly available, the information herein is based on its known preclinical status and general principles for small molecule compounds. Researchers are strongly encouraged to perform their own stability assessments for their specific experimental conditions.

Frequently Asked Questions (FAQs)

Q1: What is **AM-6494** and what is its mechanism of action?

A1: **AM-6494** is a potent and orally efficacious inhibitor of β -site amyloid precursor protein cleaving enzyme 1 (BACE1).[1][2] BACE1 is an aspartyl protease that plays a key role in the production of amyloid- β (A β) peptides, which are central to the pathology of Alzheimer's disease.[1][3][4] By inhibiting BACE1, **AM-6494** reduces the generation of A β . [2] It has demonstrated high selectivity for BACE1 over the related protease BACE2.[5]

Q2: What are the known solubility properties of **AM-6494**?

A2: Specific solubility data for **AM-6494** in various solvents is not extensively published. As a small molecule inhibitor that has undergone preclinical development, it is designed for oral efficacy, suggesting some level of aqueous solubility is achievable in formulation.[2] However, like many small molecule inhibitors, it is likely to have higher solubility in organic solvents such as dimethyl sulfoxide (DMSO) compared to aqueous buffers. Researchers should determine the solubility in their specific experimental media.

Q3: How should I prepare and store stock solutions of **AM-6494**?

A3: For initial stock solutions, using a high-purity, anhydrous grade of DMSO is recommended. Prepare a high-concentration stock (e.g., 10-50 mM) to minimize the volume of organic solvent in the final assay. Aliquot the stock solution into small, single-use volumes in tightly sealed, low-adsorption vials and store at -80°C to minimize degradation from repeated freeze-thaw cycles and exposure to moisture.

Q4: I am observing a decrease in **AM-6494** activity in my multi-day cell culture experiment. What could be the cause?

A4: A decrease in activity over time in cell culture could be due to several factors:

- **Chemical Instability:** **AM-6494** may be degrading in the culture medium at 37°C. Potential degradation pathways for small molecules include hydrolysis or oxidation.
- **Metabolic Instability:** The compound may be metabolized by the cells into less active or inactive forms.
- **Adsorption:** The compound may be adsorbing to the surface of the cell culture plates or other plasticware, reducing its effective concentration.
- **Precipitation:** The compound's solubility in the culture medium may be limited, leading to precipitation over time, especially if the initial DMSO stock was not sufficiently diluted.

It is recommended to perform a stability study of **AM-6494** in your specific cell culture medium without cells to assess its chemical stability and solubility under the experimental conditions.

Troubleshooting Guides

In Vitro Assay Instability

This guide addresses common issues encountered during in vitro experiments with **AM-6494**.

Observed Issue	Potential Cause	Troubleshooting Steps
Inconsistent results between experiments	Compound degradation in stock solution or assay buffer.	Prepare fresh stock solutions. Perform a stability study of AM-6494 in the assay buffer at the experimental temperature.
Inaccurate pipetting of viscous stock solutions.	Use positive displacement pipettes for accurate handling of DMSO stock solutions.	
Loss of compound activity over time	Hydrolysis or oxidation in aqueous buffer.	Adjust the pH of the buffer if the compound is pH-sensitive. Add antioxidants like ascorbic acid if oxidation is suspected (ensure compatibility with the assay).
Adsorption to plasticware.	Use low-binding plates and pipette tips. Include a small amount of a non-ionic surfactant (e.g., Tween-20) in the buffer, if compatible with the assay.	
Precipitate forms in assay well	Poor aqueous solubility.	Decrease the final concentration of AM-6494. Increase the percentage of co-solvent (e.g., DMSO) if the assay can tolerate it (typically $\leq 0.5\%$).

In Vivo Formulation and Stability

This guide provides troubleshooting for preparing **AM-6494** for animal studies.

Observed Issue	Potential Cause	Troubleshooting Steps
Precipitation of AM-6494 in the formulation vehicle	Exceeding the solubility limit in the chosen vehicle.	Determine the solubility of AM-6494 in individual excipients and the final vehicle.
Improper mixing or order of addition of components.	Ensure the compound is fully dissolved in a primary solvent (e.g., DMSO) before adding co-solvents or aqueous components. Use sonication or gentle heating if the compound is heat-stable.	
Variable drug exposure in pharmacokinetic studies	Inconsistent dosing of a suspension.	If using a suspension, ensure it is homogenous by continuous stirring or vortexing before and during dosing.
Degradation of the compound in the formulation.	Prepare the formulation fresh before each use. Conduct a short-term stability study of the formulation at room temperature.	

Experimental Protocols

Protocol: Assessing the Stability of AM-6494 in Aqueous Buffer

Objective: To determine the chemical stability of **AM-6494** in a specific aqueous buffer over time at different temperatures.

Materials:

- **AM-6494**
- High-purity DMSO

- Aqueous buffer of interest (e.g., PBS, pH 7.4)
- Low-binding microcentrifuge tubes
- Incubators or water baths set at desired temperatures (e.g., 4°C, 25°C, 37°C)
- HPLC or LC-MS/MS system

Methodology:

- **Prepare Stock Solution:** Prepare a 10 mM stock solution of **AM-6494** in DMSO.
- **Prepare Working Solution:** Dilute the stock solution to a final concentration of 10 µM in the pre-warmed aqueous buffer. Ensure the final DMSO concentration is low (e.g., ≤0.1%) to minimize its effect on stability.
- **Incubation:** Aliquot the working solution into separate low-binding tubes for each time point and temperature condition.
- **Time Points:** Incubate the tubes at the selected temperatures. At designated time points (e.g., 0, 1, 2, 4, 8, 24, 48 hours), remove one tube from each temperature condition.
- **Sample Analysis:** Immediately analyze the samples by a validated HPLC or LC-MS/MS method to determine the concentration of the parent **AM-6494** compound. The time zero sample represents 100% of the initial concentration.
- **Data Analysis:** Plot the percentage of **AM-6494** remaining versus time for each temperature. This will provide the degradation kinetics of the compound under the tested conditions.

Visualizations

Signaling Pathway

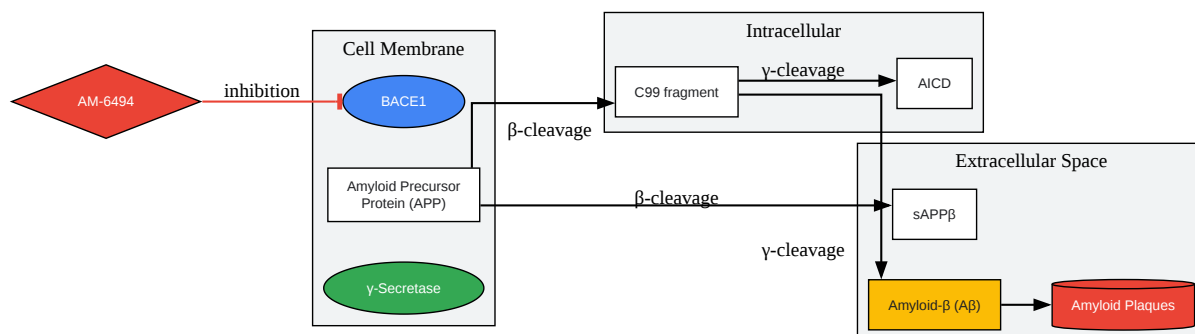

[Click to download full resolution via product page](#)

Caption: Mechanism of action of **AM-6494** in the amyloidogenic pathway.

Experimental Workflow

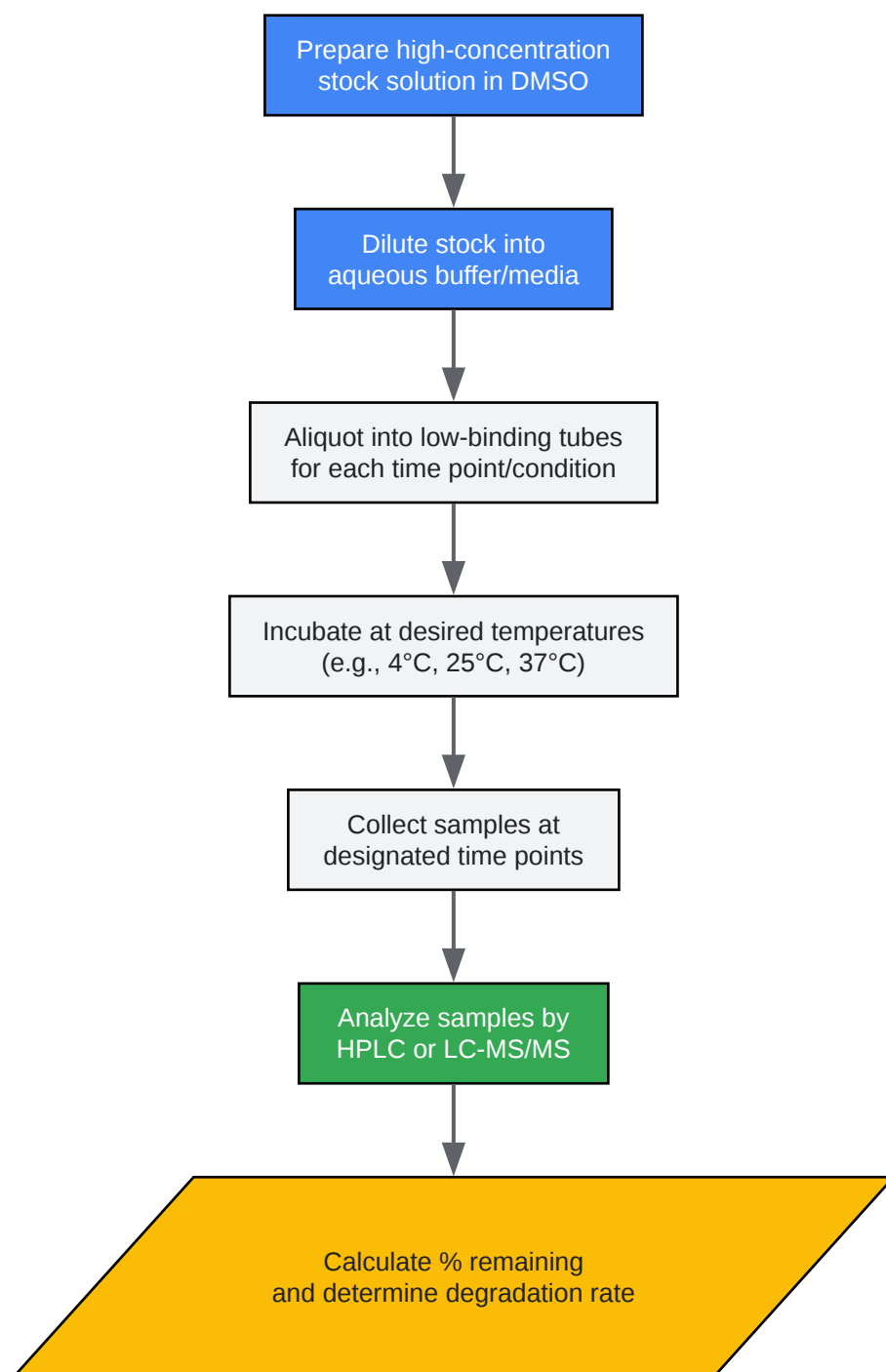

[Click to download full resolution via product page](#)

Caption: General workflow for assessing in vitro compound stability.

Troubleshooting Logic

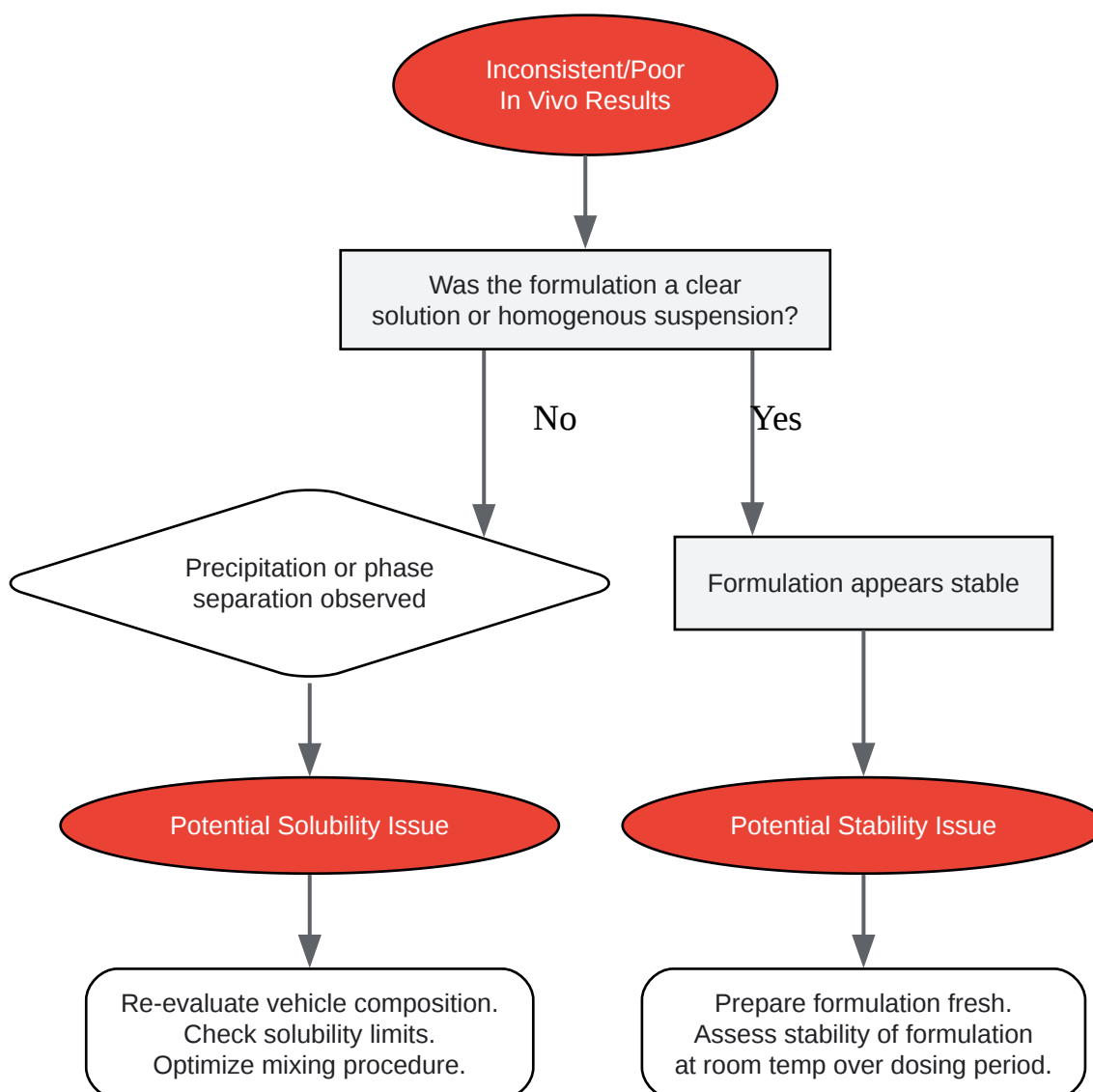

[Click to download full resolution via product page](#)

Caption: Troubleshooting logic for in vivo formulation issues.

Need Custom Synthesis?

BenchChem offers custom synthesis for rare earth carbides and specific isotopic labeling.

Email: info@benchchem.com or [Request Quote Online](#).

References

- 1. scholars.northwestern.edu [scholars.northwestern.edu]

- [2. Discovery of AM-6494: A Potent and Orally Efficacious \$\beta\$ -Site Amyloid Precursor Protein Cleaving Enzyme 1 \(BACE1\) Inhibitor with in Vivo Selectivity over BACE2 - PubMed](#) [pubmed.ncbi.nlm.nih.gov]
- [3. mdpi.com](#) [mdpi.com]
- [4. Role of BACE1 in Alzheimer's synaptic function - PMC](#) [pmc.ncbi.nlm.nih.gov]
- [5. researchgate.net](#) [researchgate.net]
- To cite this document: BenchChem. [common issues with AM-6494 stability in long-term studies]. BenchChem, [2026]. [Online PDF]. Available at: [<https://www.benchchem.com/product/b15619981/docs#common-issues-with-am-6494-stability-in-long-term-studies>]

Disclaimer & Data Validity:

The information provided in this document is for Research Use Only (RUO) and is strictly not intended for diagnostic or therapeutic procedures. While BenchChem strives to provide accurate protocols, we make no warranties, express or implied, regarding the fitness of this product for every specific experimental setup.

Technical Support: The protocols provided are for reference purposes. Unsure if this reagent suits your experiment?

Need Industrial/Bulk Grade? [Request Custom Synthesis Quote](#)

BenchChem

Our mission is to be the trusted global source of essential and advanced chemicals, empowering scientists and researchers to drive progress in science and industry.

Contact

Address: 3281 E Guasti Rd
Ontario, CA 91761, United States
Phone: (601) 213-4426
Email: info@benchchem.com

Contact our Ph.D. Support Team for a compatibility check