

Technical Support Center: UCT943 Kinase Assays

Author: BenchChem Technical Support Team. **Date:** April 2026

Compound of Interest

Compound Name: UCT943
Cat. No.: B15619827

[Get Quote](#)

This technical support center provides troubleshooting guides and frequently asked questions (FAQs) for researchers, scientists, and drug development professionals using **UCT943** in kinase assays.

Frequently Asked Questions (FAQs)

Q1: What is the primary target of **UCT943**?

A1: The primary molecular target of **UCT943** is Plasmodium falciparum phosphatidylinositol 4-kinase (PfPI4K), a lipid kinase essential for the parasite's life cycle.[1][2][3][4] **UCT943** is a potent inhibitor of PfPI4K and was developed as a next-generation antimalarial candidate.[2][3]

Q2: What is the selectivity profile of **UCT943** against human kinases?

A2: **UCT943** demonstrates high selectivity for the parasite's PI4K over the human ortholog, PI4K β (also known as PI4KB).[1][5] Studies have shown that **UCT943** has an IC₅₀ value of 5.4 μ M against human PI4K β , which is over 200-fold higher than its IC₅₀ against P. vivax PI4K (23 nM).[1] While comprehensive screening data against a broad panel of human kinases is not readily available in the public domain, a study on a related series of compounds mentioned that

a representative compound was profiled against 80 human kinases and showed inhibition of only one. This suggests a generally clean off-target profile for this chemical class.

Q3: What are the known off-target effects of **UCT943**?

A3: Besides the activity on human PI4K β , **UCT943** has been evaluated against a panel of ion channels to assess cardiotoxicity risk. The IC₅₀ values were determined to be >33 μ M for NaV1.5, CaV1.2, and KV1.5, and 10 μ M for hERG. These values indicate a low risk of cardiotoxicity at therapeutic concentrations.

Q4: How should I prepare **UCT943** for in vitro kinase assays?

A4: **UCT943** is typically dissolved in dimethyl sulfoxide (DMSO) to create a high-concentration stock solution (e.g., 10 mM). This stock solution is then serially diluted in the kinase assay buffer to achieve the desired final concentrations. It is crucial to ensure that the final DMSO concentration in the assay is low (typically \leq 1%) to avoid solvent-induced inhibition of the kinase.

Data Presentation

Table 1: **UCT943** In Vitro IC₅₀ Data

Target	Organism	IC ₅₀ (nM)	Notes
PI4K (PvPI4K)	Plasmodium vivax	23	Primary target
PI4K β (PI4KB)	Human	5400	>200-fold selectivity over human
hERG (Kv11.1)	Human	10000	Ion channel off-target
NaV1.5	Human	>33000	Ion channel off-target
CaV1.2	Human	>33000	Ion channel off-target
KV1.5	Human	>33000	Ion channel off-target

Experimental Protocols

Protocol 1: Human PI4K β (PI4KB) Kinase Assay using ADP-Glo™

This protocol is adapted from established methods for PI4K assays and is suitable for determining the inhibitory activity of **UCT943** against human PI4K β .

Materials:

- Recombinant human PI4K β enzyme
- Phosphatidylinositol (PI) substrate
- ATP (high purity)
- **UCT943** compound
- ADP-Glo™ Kinase Assay Kit (Promega)
- Kinase Assay Buffer (e.g., 25 mM HEPES pH 7.5, 10 mM MgCl₂, 0.5 mM EGTA)
- DMSO
- White, opaque 384-well plates

Procedure:

- Compound Preparation:
 - Prepare a 10 mM stock solution of **UCT943** in DMSO.
 - Perform serial dilutions of the **UCT943** stock solution in kinase assay buffer to create a concentration gradient. Ensure the final DMSO concentration in the assay does not exceed 1%.
- Kinase Reaction Setup:
 - In a 384-well plate, add 2.5 μ L of the diluted **UCT943** or DMSO (for control wells).

- Add 2.5 μL of a solution containing the PI4K β enzyme and PI substrate in kinase assay buffer. The final concentrations should be optimized for linear reaction kinetics.
- Initiate the kinase reaction by adding 5 μL of ATP solution in kinase assay buffer to each well. The final ATP concentration should be at or near the K_m for PI4K β (approximately 120 μM).^[6]
- Incubation:
 - Incubate the plate at room temperature for 60 minutes. The incubation time should be optimized to ensure the reaction is in the linear range.
- ADP Detection:
 - Add 10 μL of ADP-Glo™ Reagent to each well to stop the kinase reaction and deplete the remaining ATP.
 - Incubate the plate for 40 minutes at room temperature.
 - Add 20 μL of Kinase Detection Reagent to each well to convert ADP to ATP and generate a luminescent signal.
 - Incubate for 30-60 minutes at room temperature.
- Data Acquisition and Analysis:
 - Measure the luminescence using a plate reader.
 - Calculate the percentage of inhibition for each **UCT943** concentration relative to the DMSO control.
 - Plot the percentage of inhibition against the logarithm of the **UCT943** concentration and fit the data to a dose-response curve to determine the IC50 value.

Mandatory Visualizations

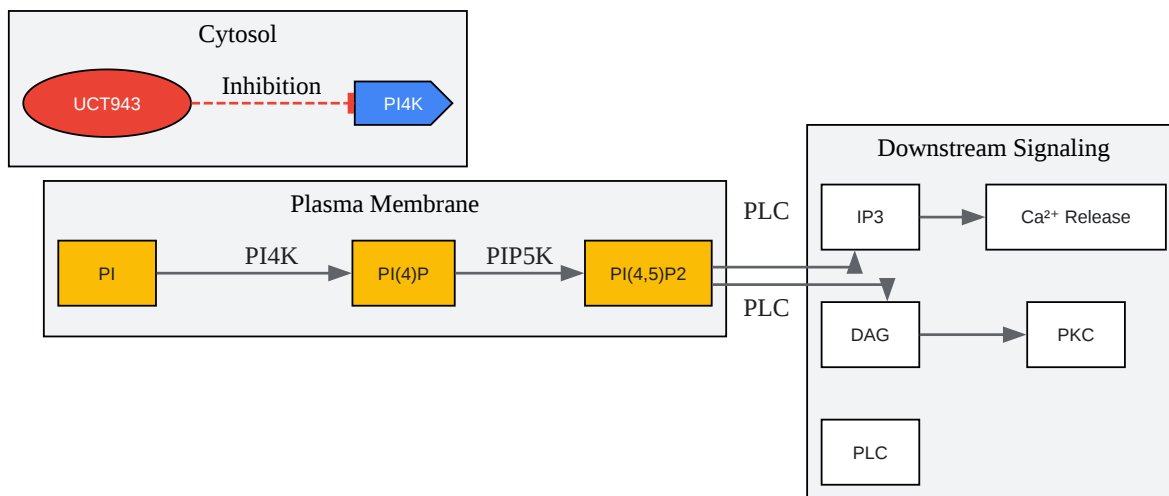

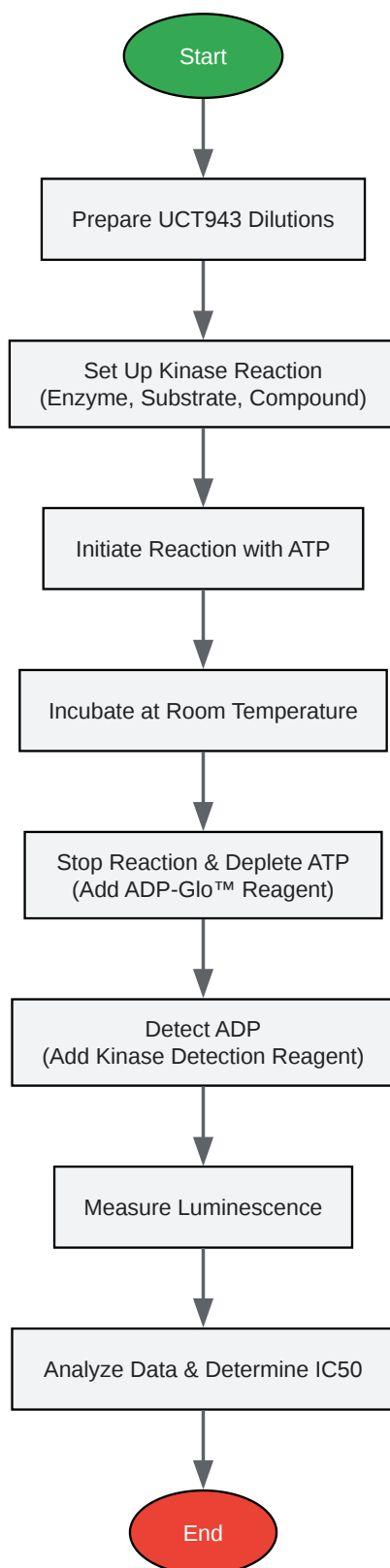

[Click to download full resolution via product page](#)

Need Custom Synthesis?

BenchChem offers custom synthesis for rare earth carbides and specific isotopic labeling.

Email: info@benchchem.com or [Request Quote Online](#).

References

- [1. UCT943, a Next-Generation Plasmodium falciparum PI4K Inhibitor Preclinical Candidate for the Treatment of Malaria - PMC \[pmc.ncbi.nlm.nih.gov\]](#)
- [2. researchgate.net \[researchgate.net\]](#)
- [3. UCT-H3D, MMV and international partners identify second potent antimalarial candidate | Medicines for Malaria Venture \[mmv.org\]](#)
- [4. UCT-943 - Drug Targets, Indications, Patents - Synapse \[synapse.patsnap.com\]](#)
- [5. journals.asm.org \[journals.asm.org\]](#)
- [6. A homogeneous and nonisotopic assay for phosphatidylinositol 4-kinases - PMC \[pmc.ncbi.nlm.nih.gov\]](#)
- To cite this document: BenchChem. [Technical Support Center: UCT943 Kinase Assays]. BenchChem, [2026]. [Online PDF]. Available at: [\[https://www.benchchem.com/product/b15619827/docs#technical-support-center-uct943-kinase-assays\]](https://www.benchchem.com/product/b15619827/docs#technical-support-center-uct943-kinase-assays)

Disclaimer & Data Validity:

The information provided in this document is for Research Use Only (RUO) and is strictly not intended for diagnostic or therapeutic procedures. While BenchChem strives to provide accurate protocols, we make no warranties, express or implied, regarding the fitness of this product for every specific experimental setup.

Technical Support: The protocols provided are for reference purposes. Unsure if this reagent suits your experiment?

Need Industrial/Bulk Grade? [Request Custom Synthesis Quote](#)

BenchChem

Our mission is to be the trusted global source of essential and advanced chemicals, empowering scientists and researchers to drive progress in science and industry.

Contact

Address: 3281 E Guasti Rd

Ontario, CA 91761, United States

Phone: (601) 213-4426

Email: info@benchchem.com

[Contact our Ph.D. Support Team for a compatibility check](#)