

# BI-605906: A Technical Guide for Inflammation Research

**Author:** BenchChem Technical Support Team. **Date:** April 2026

## Compound of Interest

Compound Name: BI605906  
Cat. No.: B15619562

[Get Quote](#)

For Researchers, Scientists, and Drug Development Professionals

This document provides an in-depth technical overview of BI-605906, a potent and selective inhibitor of I $\kappa$ B kinase  $\beta$  (IKK $\beta$ ), for its application in inflammation research.

## Introduction

Inflammation is a complex biological response implicated in a wide range of physiological and pathological processes. The nuclear factor- $\kappa$ B (NF- $\kappa$ B) signaling pathway is a cornerstone of the inflammatory response, regulating the expression of numerous pro-inflammatory genes, including cytokines, chemokines, and adhesion molecules.[1][2] At the heart of this pathway lies the I $\kappa$ B kinase (IKK) complex, with IKK $\beta$  being the critical catalytic subunit responsible for the phosphorylation and subsequent degradation of the inhibitor of  $\kappa$ B (I $\kappa$ B), leading to NF- $\kappa$ B activation.[2][3][4] Consequently, IKK $\beta$  has emerged as a key therapeutic target for a multitude of inflammatory disorders.[3][5]

BI-605906 is a chemical probe designed by Boehringer Ingelheim that acts as a potent and highly selective, ATP-competitive inhibitor of IKK $\beta$ . [5][6] Its utility as a research tool is underscored by its demonstrated efficacy in mechanistically consistent cell-based assays and in vivo models of inflammation.[5] This guide summarizes the key quantitative data, details

relevant experimental protocols, and visualizes the underlying signaling pathways to facilitate the use of BI-605906 in inflammation research.

## Mechanism of Action

BI-605906 exerts its anti-inflammatory effects by directly inhibiting the kinase activity of IKK $\beta$ .<sup>[5]</sup><sup>[6]</sup> In the canonical NF- $\kappa$ B pathway, pro-inflammatory stimuli such as tumor necrosis factor- $\alpha$  (TNF- $\alpha$ ) or interleukin-1 beta (IL-1 $\beta$ ) activate upstream kinases that, in turn, activate the IKK complex.<sup>[1][2]</sup> Activated IKK $\beta$  then phosphorylates I $\kappa$ B $\alpha$ , targeting it for ubiquitination and proteasomal degradation.<sup>[1][7]</sup> The degradation of I $\kappa$ B $\alpha$  releases the NF- $\kappa$ B heterodimer (typically p65/p50), allowing it to translocate to the nucleus and initiate the transcription of target inflammatory genes.<sup>[1][4]</sup> BI-605906, by binding to the ATP-binding pocket of IKK $\beta$ , prevents the phosphorylation of I $\kappa$ B $\alpha$ , thereby blocking the entire downstream signaling cascade.<sup>[5][7]</sup>

## Quantitative Data

The following tables summarize the key in vitro and cellular potency and selectivity data for BI-605906.

Table 1: In Vitro and Cellular Activity of BI-605906

Parameter	Value	Species/Cell Line	Experimental Conditions	Source(s)
IKK $\beta$ Inhibition (IC50)	50 nM	-	Biochemical Assay	[5]
380 nM	-	Biochemical Assay (at 0.1 mM ATP)	[6][8][9][10][11][12]	
I $\kappa$ B $\alpha$ Phosphorylation Inhibition (EC50)	0.9 $\mu$ M	HeLa cells	-	[5]
ICAM-1 Expression Inhibition (EC50)	0.7 $\mu$ M	HeLa cells	-	[5]

Table 2: Kinase Selectivity Profile of BI-605906

Kinase/Target	Inhibition/Activity	Concentration	Source(s)
IKK $\alpha$	Inactive (IC <sub>50</sub> > 10 $\mu$ M)	-	[5]
IKK $\gamma$ (NEMO)	Inactive (IC <sub>50</sub> > 10 $\mu$ M)	-	[5]
IKK $\epsilon$	No significant inhibition	-	[6]
TBK1	No significant inhibition	-	[6]
Insulin-like growth factor 1 (IGF1) receptor	IC <sub>50</sub> = 7.6 $\mu$ M	-	[6][8][10][11][12]
GAK	93% inhibition	10 $\mu$ M	[5]
AAK1	87% inhibition	10 $\mu$ M	[5]
IRAK3	76% inhibition	10 $\mu$ M	[5]
Panel of >100 other protein kinases	No significant inhibition	-	[6][8][12]

Table 3: In Vivo Efficacy of BI-605906

Animal Model	Dose	Efficacy	Source(s)
Rat Collagen-Induced Arthritis	60 mg/kg	Comparable efficacy to anti-TNF- $\alpha$ standard etanercept	[5]

## Experimental Protocols

### In Vitro IKK $\beta$ Kinase Inhibition Assay

This protocol is a representative method for determining the in vitro inhibitory activity of BI-605906 against IKK $\beta$ .

- Reagents and Materials:
  - Recombinant human IKK $\beta$
  - IKK $\beta$  substrate (e.g., a peptide corresponding to the phosphorylation sites on I $\kappa$ B $\alpha$ )
  - BI-605906 (and other test compounds)
  - ATP (e.g., at a concentration of 0.1 mM)[6]
  - Kinase buffer
  - Detection reagent (e.g., ADP-Glo™ Kinase Assay)
  - 384-well plates
- Procedure:
  1. Prepare serial dilutions of BI-605906 in DMSO and then dilute in kinase buffer.
  2. Add the diluted BI-605906 or vehicle control (DMSO) to the wells of a 384-well plate.
  3. Add the IKK $\beta$  enzyme and substrate to the wells.
  4. Initiate the kinase reaction by adding ATP.
  5. Incubate the plate at room temperature for a specified time (e.g., 60 minutes).
  6. Stop the reaction and measure the kinase activity using a suitable detection reagent according to the manufacturer's instructions.
  7. Calculate the IC<sub>50</sub> value by fitting the dose-response data to a four-parameter logistic equation.

## Cellular Inhibition of I $\kappa$ B $\alpha$ Phosphorylation (Western Blot)

This protocol describes a method to assess the cellular activity of BI-605906 by measuring the inhibition of TNF- $\alpha$ -induced I $\kappa$ B $\alpha$  phosphorylation in HeLa cells.[\[5\]](#)

- Reagents and Materials:
  - HeLa cells
  - Complete cell culture medium
  - BI-605906
  - TNF- $\alpha$
  - Lysis buffer
  - Primary antibodies (anti-phospho-I $\kappa$ B $\alpha$ , anti-I $\kappa$ B $\alpha$ , anti- $\beta$ -actin)
  - HRP-conjugated secondary antibody
  - Chemiluminescent substrate
- Procedure:
  1. Seed HeLa cells in 6-well plates and allow them to adhere overnight.
  2. Pre-treat the cells with varying concentrations of BI-605906 or vehicle control for 1 hour.
  3. Stimulate the cells with TNF- $\alpha$  (e.g., 10 ng/mL) for 15 minutes.
  4. Wash the cells with ice-cold PBS and lyse them in lysis buffer.
  5. Determine the protein concentration of the lysates.
  6. Separate the proteins by SDS-PAGE and transfer them to a PVDF membrane.
  7. Block the membrane and incubate with primary antibodies overnight at 4°C.

8. Wash the membrane and incubate with the HRP-conjugated secondary antibody.
9. Detect the protein bands using a chemiluminescent substrate and an imaging system.
10. Quantify the band intensities and normalize the phospho-I $\kappa$ B $\alpha$  signal to total I $\kappa$ B $\alpha$  and the loading control ( $\beta$ -actin).
11. Calculate the EC50 value from the dose-response curve.

## In Vivo Model of Collagen-Induced Arthritis in Rats

This protocol provides a general framework for evaluating the in vivo efficacy of BI-605906 in a rat model of collagen-induced arthritis.[\[5\]](#)

- Animals:
  - Lewis rats
- Induction of Arthritis:
  1. Emulsify bovine type II collagen with complete Freund's adjuvant.
  2. On day 0, immunize the rats with an intradermal injection of the collagen emulsion at the base of the tail.
  3. On day 7, administer a booster injection of collagen in incomplete Freund's adjuvant.
- Treatment:
  1. Prepare BI-605906 for administration (e.g., in a vehicle of 10% DMSO, 40% PEG300, 5% Tween-80, and 45% Saline for a clear solution, or a suspension for oral/intraperitoneal injection).[\[6\]](#)
  2. Begin treatment with BI-605906 (e.g., 60 mg/kg) or vehicle control at the onset of clinical signs of arthritis.
  3. Administer the treatment daily via the desired route (e.g., oral gavage).
- Assessment of Arthritis:

1. Monitor the animals daily for clinical signs of arthritis, such as paw swelling, erythema, and joint stiffness.
2. Measure paw volume using a plethysmometer.
3. At the end of the study, collect tissues for histological analysis to assess joint inflammation, cartilage destruction, and bone erosion.
4. Measure serum levels of inflammatory biomarkers (e.g., cytokines).

## Signaling Pathways and Experimental Workflows



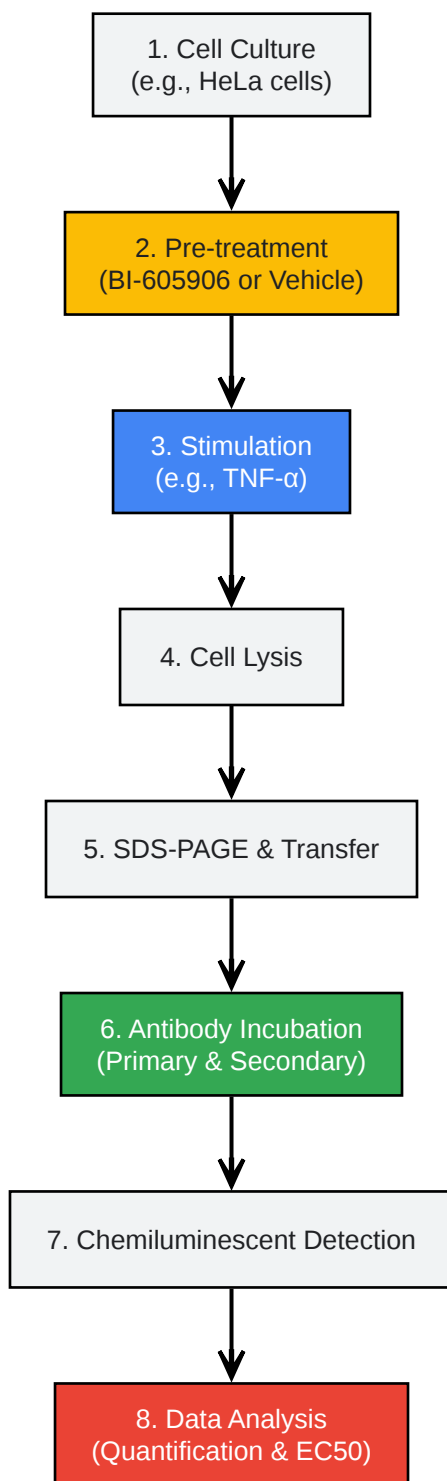

[Click to download full resolution via product page](#)

### Need Custom Synthesis?

BenchChem offers custom synthesis for rare earth carbides and specific isotopic labeling.

Email: [info@benchchem.com](mailto:info@benchchem.com) or [Request Quote Online](#).

## References

- [1. WO2002060386A2 - METHODS OF TREATING INFLAMMATORY AND IMMUNE DISEASES USING INHIBITORS OF I \$\kappa\$ B KINASE \(IKK\) - Google Patents \[patents.google.com\]](#)
- [2. A selective novel low-molecular-weight inhibitor of I \$\kappa\$ B kinase- \$\beta\$  \(IKK- \$\beta\$ \) prevents pulmonary inflammation and shows broad anti-inflammatory activity - PMC \[pmc.ncbi.nlm.nih.gov\]](#)
- [3. An antiinflammatory role for IKK \$\beta\$  through the inhibition of “classical” macrophage activation - PMC \[pmc.ncbi.nlm.nih.gov\]](#)
- [4. scholarhub.ui.ac.id \[scholarhub.ui.ac.id\]](#)
- [5. Pardon Our Interruption \[opnme.com\]](#)
- [6. medchemexpress.com \[medchemexpress.com\]](#)
- [7. researchgate.net \[researchgate.net\]](#)
- [8. rndsystems.com \[rndsystems.com\]](#)
- [9. I \$\kappa\$ B kinase \(IKK\) \(inhibitors, antagonists, agonists\)-ProbeChem.com \[probechem.com\]](#)
- [10. selleck.co.jp \[selleck.co.jp\]](#)
- [11. selleckchem.com \[selleckchem.com\]](#)
- [12. BI 605906 | I \$\kappa\$ B Kinase | Tocris Bioscience \[toocris.com\]](#)
- To cite this document: BenchChem. [BI-605906: A Technical Guide for Inflammation Research]. BenchChem, [2026]. [Online PDF]. Available at: [<https://www.benchchem.com/product/b15619562/docs#bi-605906-a-technical-guide-for-inflammation-research>]

---

### Disclaimer & Data Validity:

The information provided in this document is for Research Use Only (RUO) and is strictly not intended for diagnostic or therapeutic procedures. While BenchChem strives to provide accurate protocols, we make no warranties, express or implied, regarding the fitness of this product for every specific experimental setup.

**Technical Support:** The protocols provided are for reference purposes. Unsure if this reagent suits your experiment?

**Need Industrial/Bulk Grade?** [Request Custom Synthesis Quote](#)

## BenchChem

Our mission is to be the trusted global source of essential and advanced chemicals, empowering scientists and researchers to drive progress in science and industry.

### Contact

Address: 3281 E Guasti Rd  
Ontario, CA 91761, United States  
Phone: (601) 213-4426  
Email: [info@benchchem.com](mailto:info@benchchem.com)

[Contact our Ph.D. Support Team for a compatibility check](#)