

# Application Notes: GID4 Ligand 3 in Cancer Research

**Author:** BenchChem Technical Support Team. **Date:** April 2026

## Compound of Interest

Compound Name: GID4 Ligand 3

Cat. No.: B15619748

[Get Quote](#)

## Harnessing the GID4 E3 Ligase for Targeted Protein Degradation in Oncology

The burgeoning field of targeted protein degradation (TPD) offers a novel therapeutic modality in cancer research, aiming to eliminate pathogenic proteins rather than merely inhibiting them. A key strategy in TPD is the use of proteolysis-targeting chimeras (PROTACs), heterobifunctional molecules that recruit a target protein to an E3 ubiquitin ligase, leading to its ubiquitination and subsequent degradation by the proteasome. While the majority of PROTACs in development utilize the VHL or cereblon E3 ligases, there is a growing effort to expand the repertoire of utilized E3 ligases to overcome resistance and enhance tissue- and tumor-specific protein degradation.

GID4 (Glucose-Induced Degradation protein 4), a substrate receptor of the CTLH (C-terminal to LisH) E3 ubiquitin ligase complex, has emerged as a promising new E3 ligase for TPD applications.[1][2][3] Small molecule binders of GID4, such as **GID4 Ligand 3** (also referred to as compound 16), have been developed to enable the recruitment of this E3 ligase for the degradation of oncoproteins.[4] These ligands serve as the E3 ligase-recruiting moiety in GID4-based PROTACs, which have demonstrated preclinical efficacy in cancer models.

This document provides detailed application notes and protocols for researchers, scientists, and drug development professionals on the utilization of **GID4 Ligand 3** and derivative PROTACs in cancer research.

## Mechanism of Action: GID4-Based PROTACs

GID4-based PROTACs are heterobifunctional molecules comprising three key components: a ligand that binds to the protein of interest (POI), a linker, and a GID4-recruiting ligand, such as **GID4 Ligand 3**. The PROTAC functions by inducing the formation of a ternary complex between the POI and the GID4 subunit of the CTLH E3 ligase complex.<sup>[1][2]</sup> This proximity facilitates the transfer of ubiquitin from an E2-conjugating enzyme to the POI. The resulting polyubiquitinated POI is then recognized and degraded by the 26S proteasome. A prominent example of a target protein for GID4-based PROTACs in cancer is BRD4, a member of the BET (Bromodomain and Extra-Terminal) family of proteins that acts as an epigenetic reader and is a key driver of oncogene expression, including c-Myc.<sup>[1][2][5]</sup>

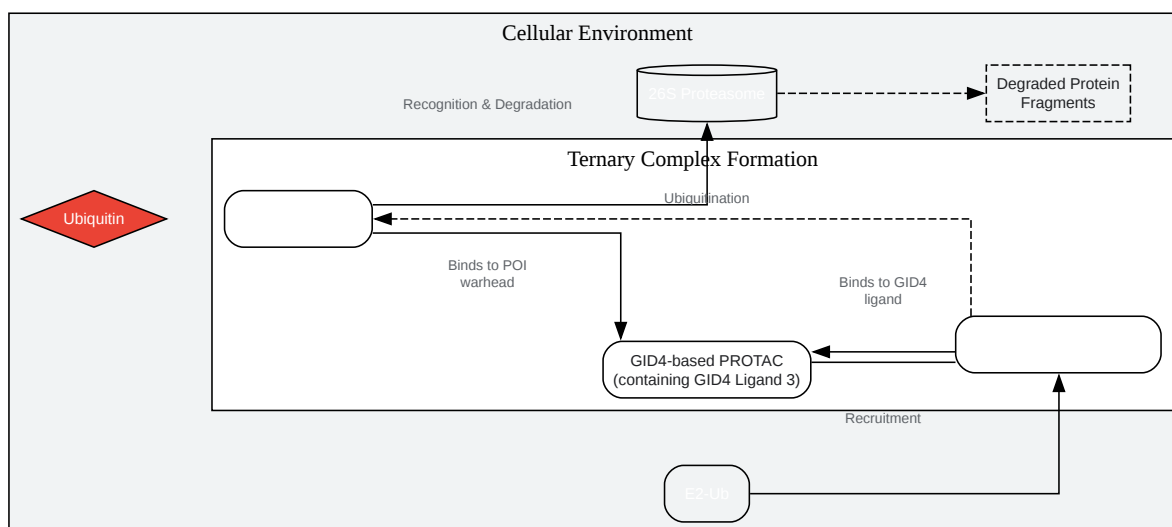

[Click to download full resolution via product page](#)

Caption: GID4-PROTAC mediated protein degradation pathway.

## Quantitative Data Summary

The following tables summarize the binding affinities and degradation potencies of GID4 ligands and derived PROTACs from published literature.

Table 1: Binding Affinities of GID4 Ligands

Compound	Assay	Kd ( $\mu\text{M}$ )	IC50 ( $\mu\text{M}$ )	Reference
GID4 Ligand 3 (compound 16)	In vitro	110	148.5	[4]
Compound 67	In vitro	17	-	[6]
Compound 88	In vitro	5.6	-	[2]
PFI-7	SPR	0.079	-	[7]
PFI-7	NanoBRET	-	0.57	[7]
Compound 14	Biophysical assays	0.023	-	[8]

Table 2: In Vitro Efficacy of GID4-Based PROTACs Against BRD4

PROTAC	Cell Line	DC50 ( $\mu\text{M}$ )	Assay Time (h)	Reference
NEP108	U2OS	~3.8	18	[9]
NEP162	U2OS	Not specified	18	[1][2]

## Experimental Protocols

Detailed methodologies for key experiments in the evaluation of **GID4 Ligand 3** and its derivative PROTACs are provided below.

## Protocol 1: Western Blot Analysis of BRD4 Degradation

This protocol details the steps to assess the degradation of a target protein, such as BRD4, in cancer cells following treatment with a GID4-based PROTAC.

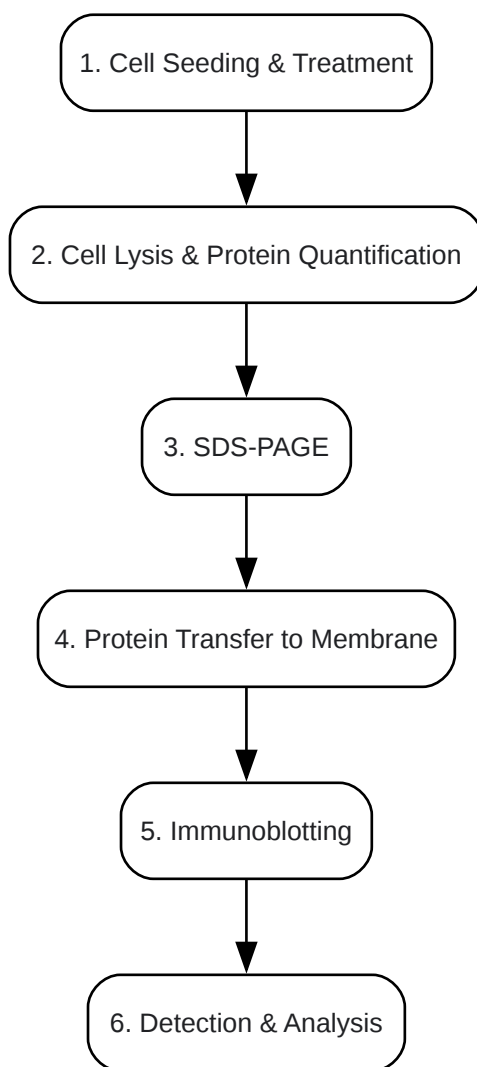

[Click to download full resolution via product page](#)

Caption: Workflow for Western blot analysis of protein degradation.

Materials:

- Cancer cell line (e.g., U2OS, HeLa, MDA-MB-231)[5]
- Complete growth medium (e.g., DMEM with 10% FBS)

- GID4-based PROTAC (e.g., NEP162)
- DMSO (vehicle control)
- Proteasome inhibitor (e.g., MG132, as a control)
- Lysis buffer (e.g., RIPA buffer with protease and phosphatase inhibitors)
- BCA Protein Assay Kit
- SDS-PAGE gels, running buffer, and transfer buffer
- PVDF or nitrocellulose membrane
- Blocking buffer (e.g., 5% non-fat milk or BSA in TBST)
- Primary antibodies: anti-BRD4, anti-c-Myc, anti-GAPDH (or other loading control)
- HRP-conjugated secondary antibody
- Chemiluminescent substrate

#### Procedure:

- Cell Seeding and Treatment:
  - Seed cells in 6-well plates to achieve 70-80% confluency at the time of harvest.
  - Allow cells to adhere overnight.
  - Treat cells with varying concentrations of the GID4-based PROTAC (e.g., 0.1, 1, 10  $\mu$ M) for a specified time course (e.g., 4, 8, 16, 24 hours). Include a DMSO vehicle control.
- Cell Lysis and Protein Quantification:
  - Wash cells with ice-cold PBS and lyse with RIPA buffer.
  - Collect cell lysates and centrifuge to pellet debris.

- Determine the protein concentration of the supernatant using a BCA assay.
- SDS-PAGE and Protein Transfer:
  - Normalize protein concentrations and prepare samples with Laemmli buffer.
  - Load equal amounts of protein onto an SDS-PAGE gel and perform electrophoresis.
  - Transfer the separated proteins to a PVDF or nitrocellulose membrane.
- Immunoblotting:
  - Block the membrane with blocking buffer for 1 hour at room temperature.
  - Incubate the membrane with primary antibodies (e.g., anti-BRD4, anti-c-Myc, and a loading control) overnight at 4°C.
  - Wash the membrane with TBST and incubate with the appropriate HRP-conjugated secondary antibody for 1 hour at room temperature.
- Detection and Analysis:
  - Wash the membrane with TBST.
  - Apply the chemiluminescent substrate and visualize the protein bands using an imaging system.
  - Quantify band intensities to determine the extent of protein degradation relative to the loading control.

## Protocol 2: Cell Viability Assay

This protocol is used to determine the anti-proliferative effect of GID4-based PROTACs on cancer cells.

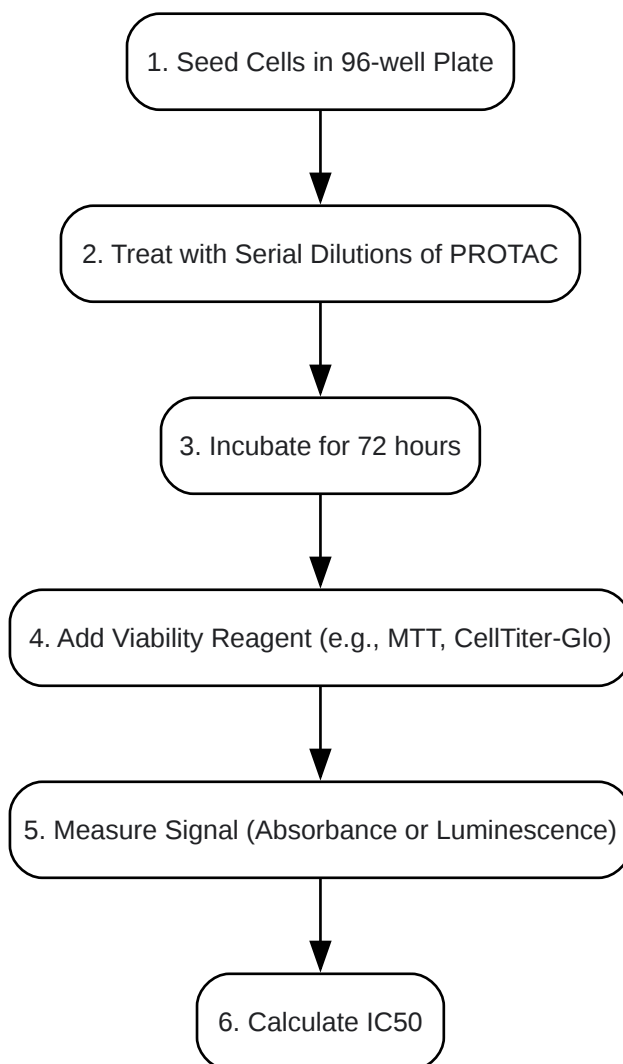

[Click to download full resolution via product page](#)

Caption: Workflow for a cell viability assay.

Materials:

- Cancer cell line
- Complete growth medium
- GID4-based PROTAC
- 96-well, opaque-walled plates (for luminescence assays) or clear plates (for absorbance assays)

- Cell viability reagent (e.g., CellTiter-Glo® Luminescent Cell Viability Assay or MTT reagent)
- Plate reader capable of measuring luminescence or absorbance

Procedure:

- Cell Seeding:
  - Seed cells in a 96-well plate at a density that allows for logarithmic growth over the experimental period.
- Compound Treatment:
  - After cell adherence, treat with a serial dilution of the GID4-based PROTAC. Include a vehicle control.
- Incubation:
  - Incubate the plate for a desired duration (e.g., 72 hours) at 37°C in a CO2 incubator.
- Assay Measurement:
  - Equilibrate the plate and the cell viability reagent to room temperature.
  - Add the reagent to each well according to the manufacturer's instructions.
  - For CellTiter-Glo®, mix on an orbital shaker to induce lysis and incubate to stabilize the luminescent signal.
  - For MTT, incubate to allow for formazan crystal formation, then solubilize the crystals.
  - Record the luminescence or absorbance using a plate reader.
- Data Analysis:
  - Normalize the data to the vehicle control and plot the results to determine the IC50 value.

## Protocol 3: In Vivo Xenograft Tumor Growth Inhibition Study

This protocol outlines a general procedure for evaluating the anti-tumor efficacy of a GID4-based PROTAC in a mouse xenograft model.

### Materials:

- Immunocompromised mice (e.g., BALB/c nude mice)
- Cancer cell line for tumor implantation
- GID4-based PROTAC formulated for in vivo administration
- Vehicle control solution
- Calipers for tumor measurement

### Procedure:

- Tumor Implantation:
  - Subcutaneously inject cancer cells into the flank of the mice.
  - Allow tumors to grow to a palpable size (e.g., 100 mm<sup>3</sup>).
- Animal Grouping and Dosing:
  - Randomize mice into treatment and control groups.
  - Administer the GID4-based PROTAC (e.g., intraperitoneally) at a specified dose and schedule (e.g., 10 mg/kg, twice daily for 14 days).<sup>[10]</sup> Administer the vehicle solution to the control group.
- Tumor Measurement and Body Weight Monitoring:
  - Measure tumor volume using calipers at regular intervals.

- Monitor the body weight of the mice as an indicator of toxicity.
- Data Analysis:
  - Calculate tumor growth inhibition (TGI) to assess the efficacy of the treatment.

## Protocol 4: Co-Immunoprecipitation (Co-IP) for Ternary Complex Formation

This protocol is designed to confirm the formation of the POI-PROTAC-GID4 ternary complex.

Materials:

- Cells expressing the target protein and GID4
- GID4-based PROTAC
- Co-IP lysis buffer
- Antibody against the target protein or an epitope tag
- Protein A/G magnetic beads
- Wash buffer
- Elution buffer
- Western blot reagents

Procedure:

- Cell Treatment and Lysis:
  - Treat cells with the GID4-based PROTAC or vehicle control.
  - Lyse the cells with Co-IP lysis buffer.
- Immunoprecipitation:

- Pre-clear the cell lysates.
- Incubate the lysates with an antibody against the target protein.
- Add protein A/G magnetic beads to pull down the antibody-protein complex.
- Washing and Elution:
  - Wash the beads to remove non-specific binding.
  - Elute the protein complexes from the beads.
- Western Blot Analysis:
  - Analyze the eluates by Western blotting using antibodies against the target protein and GID4 to detect the co-immunoprecipitated proteins.

## Conclusion

**GID4 Ligand 3** and the resulting GID4-based PROTACs represent a promising new frontier in targeted cancer therapy. The protocols and data presented here provide a framework for researchers to explore the potential of this novel E3 ligase in their own cancer research and drug development programs. As our understanding of the CTLH complex and its substrates grows, so too will the opportunities for developing innovative and effective cancer treatments based on GID4 recruitment.

### *Need Custom Synthesis?*

*BenchChem offers custom synthesis for rare earth carbides and specific isotopic labeling.*

*Email: [info@benchchem.com](mailto:info@benchchem.com) or [Request Quote Online](#).*

## References

- [1. researchgate.net \[researchgate.net\]](https://www.researchgate.net)
- [2. Design of PROTACs utilizing the E3 ligase GID4 for targeted protein degradation - PubMed \[pubmed.ncbi.nlm.nih.gov\]](https://pubmed.ncbi.nlm.nih.gov/)

- [3. pubs.acs.org \[pubs.acs.org\]](https://pubs.acs.org)
- [4. benchchem.com \[benchchem.com\]](https://benchchem.com)
- [5. benchchem.com \[benchchem.com\]](https://benchchem.com)
- [6. Discovery and Structural Characterization of Small Molecule Binders of the Human CTLH E3 Ligase Subunit GID4 - PMC \[pmc.ncbi.nlm.nih.gov\]](https://pubmed.ncbi.nlm.nih.gov)
- [7. biorxiv.org \[biorxiv.org\]](https://biorxiv.org)
- [8. GID4 \(human\) cellular assay – openlabnotebooks.org \[openlabnotebooks.org\]](https://openlabnotebooks.org)
- [9. Protocol to test for the formation of ternary protein complexes in vivo or in vitro using a two-step immunoprecipitation approach - PubMed \[pubmed.ncbi.nlm.nih.gov\]](https://pubmed.ncbi.nlm.nih.gov)
- [10. PROTAC derivatization of natural products for target identification and drug discovery: Design of evodiamine-based PROTACs as novel REXO4 degraders - PMC \[pmc.ncbi.nlm.nih.gov\]](https://pubmed.ncbi.nlm.nih.gov)
- To cite this document: BenchChem. [Application Notes: GID4 Ligand 3 in Cancer Research]. BenchChem, [2026]. [Online PDF]. Available at: [\[https://www.benchchem.com/product/b15619748/docs#application-notes-gid4-ligand-3-in-cancer-research\]](https://www.benchchem.com/product/b15619748/docs#application-notes-gid4-ligand-3-in-cancer-research)

---

#### Disclaimer & Data Validity:

The information provided in this document is for Research Use Only (RUO) and is strictly not intended for diagnostic or therapeutic procedures. While BenchChem strives to provide accurate protocols, we make no warranties, express or implied, regarding the fitness of this product for every specific experimental setup.

**Technical Support:** The protocols provided are for reference purposes. Unsure if this reagent suits your experiment?

**Need Industrial/Bulk Grade?** [Request Custom Synthesis Quote](#)

# BenchChem

Our mission is to be the trusted global source of essential and advanced chemicals, empowering scientists and researchers to drive progress in science and industry.

## Contact

Address: 3281 E Guasti Rd

Ontario, CA 91761, United States

Phone: (601) 213-4426

Email: [info@benchchem.com](mailto:info@benchchem.com)

[Contact our Ph.D. Support Team for a compatibility check](#)