

Technical Support Center: Minimizing Off-Target Effects of TCS 1102

Author: BenchChem Technical Support Team. **Date:** April 2026

Compound of Interest

Compound Name: Tcs 1102
Cat. No.: B15618917

[Get Quote](#)

This technical support center provides researchers, scientists, and drug development professionals with comprehensive guidance on minimizing the off-target effects of **TCS 1102**, a potent dual orexin receptor antagonist. By implementing the strategies and protocols outlined below, researchers can enhance the specificity of their experiments and ensure the reliability of their data.

Frequently Asked Questions (FAQs)

Q1: What is **TCS 1102** and what are its primary targets?

TCS 1102 is a potent, dual antagonist of orexin receptor 1 (OX1R) and orexin receptor 2 (OX2R).^{[1][2][3][4][5][6][7]} It exhibits high affinity for these receptors, with K_i values of 3 nM for OX1R and 0.2 nM for OX2R.^{[1][3][4][7]} Orexin receptors are G-protein coupled receptors that play a crucial role in regulating arousal, wakefulness, and appetite.

Q2: What are off-target effects and why are they a concern when using **TCS 1102**?

Off-target effects occur when a compound, such as **TCS 1102**, binds to and modulates the activity of proteins other than its intended targets (OX1R and OX2R). These unintended interactions can lead to misinterpretation of experimental results, cellular toxicity, and a lack of

translational relevance. Minimizing off-target effects is critical for obtaining accurate and reproducible data.

Q3: How can I proactively minimize off-target effects in my experimental design?

Several strategies can be employed to reduce the likelihood of off-target effects:

- Use the Lowest Effective Concentration: Titrate **TCS 1102** to determine the lowest concentration that elicits the desired on-target effect. Higher concentrations are more likely to engage lower-affinity off-target proteins.
- Employ Control Compounds: Include a structurally similar but inactive analog of **TCS 1102** as a negative control. This helps to ensure that the observed effects are not due to the chemical scaffold itself.
- Orthogonal Approaches: Use alternative methods to validate your findings. This could include using another orexin receptor antagonist with a different chemical structure or employing genetic approaches like siRNA or CRISPR-Cas9 to knock down the orexin receptors.

Troubleshooting Guide: Identifying and Mitigating Off-Target Effects

This guide provides a systematic approach to troubleshooting potential off-target effects in your experiments with **TCS 1102**.

Scenario 1: Inconsistent results between different cell lines.

- Possible Cause: The expression levels of on-target (OX1R, OX2R) or off-target proteins may vary between cell lines.
- Troubleshooting Steps:
 - Confirm Target Expression: Verify the expression of OX1R and OX2R in your cell lines of interest using techniques like qPCR or Western blotting.

- Perform Dose-Response Curves: Generate dose-response curves for **TCS 1102** in each cell line to determine the EC50/IC50. A significant shift in potency may indicate differing target or off-target expression.
- Consider Off-Target Profiling: If inconsistencies persist, consider performing an unbiased off-target screening assay, such as a kinase panel or a broader receptor profiling service.

Scenario 2: Observed phenotype does not match known orexin signaling pathways.

- Possible Cause: The observed effect may be due to the modulation of an unknown off-target.
- Troubleshooting Steps:
 - Literature Review: Conduct a thorough literature search to see if similar unexpected phenotypes have been reported for other orexin antagonists.
 - Target Validation: Use genetic methods (siRNA, CRISPR-Cas9) to knock down OX1R and OX2R. If the phenotype persists in the absence of the intended targets, it is likely an off-target effect.
 - Cellular Thermal Shift Assay (CETSA): Perform a CETSA to confirm direct binding of **TCS 1102** to OX1R and OX2R in your cellular model. This can also be adapted to identify novel binding partners.

Quantitative Data Summary

Table 1: On-Target Affinity of **TCS 1102**

Target	Ki (nM)
Orexin Receptor 1 (OX1R)	3
Orexin Receptor 2 (OX2R)	0.2

Data compiled from multiple sources.[\[1\]](#)[\[3\]](#)[\[4\]](#)[\[7\]](#)

Key Experimental Protocols

Protocol 1: Cellular Thermal Shift Assay (CETSA) for Target Engagement

Objective: To confirm the direct binding of **TCS 1102** to its target proteins (OX1R and OX2R) in intact cells.

Methodology:

- Cell Treatment: Treat intact cells with **TCS 1102** at various concentrations or with a vehicle control (e.g., DMSO).
- Heat Challenge: Heat the cell lysates or intact cells across a range of temperatures (e.g., 40-70°C).
- Lysis and Centrifugation: Lyse the cells and centrifuge to separate the soluble protein fraction from the aggregated, denatured proteins.
- Protein Quantification: Collect the supernatant and quantify the amount of soluble target protein (OX1R or OX2R) using Western blotting or other protein detection methods.
- Data Analysis: Plot the amount of soluble protein as a function of temperature. A shift in the melting curve to a higher temperature in the presence of **TCS 1102** indicates target engagement.

Protocol 2: Genetic Validation using CRISPR-Cas9 Knockout

Objective: To determine if the genetic removal of the target proteins (OX1R and OX2R) recapitulates the phenotype observed with **TCS 1102** treatment.

Methodology:

- gRNA Design and Cloning: Design and clone guide RNAs (gRNAs) targeting the genes encoding OX1R and OX2R into a Cas9 expression vector.
- Transfection and Selection: Transfect the gRNA/Cas9 plasmids into the cells and select for successfully transfected cells.

- Clonal Isolation: Isolate single-cell clones.
- Knockout Validation: Verify the knockout of OX1R and OX2R at the genomic, mRNA, and protein levels.
- Phenotypic Analysis: Perform the relevant phenotypic assays on the knockout clones and compare the results to cells treated with **TCS 1102**. If the phenotype is absent in the knockout cells, it provides strong evidence that the effect of **TCS 1102** is on-target.

Visualizations

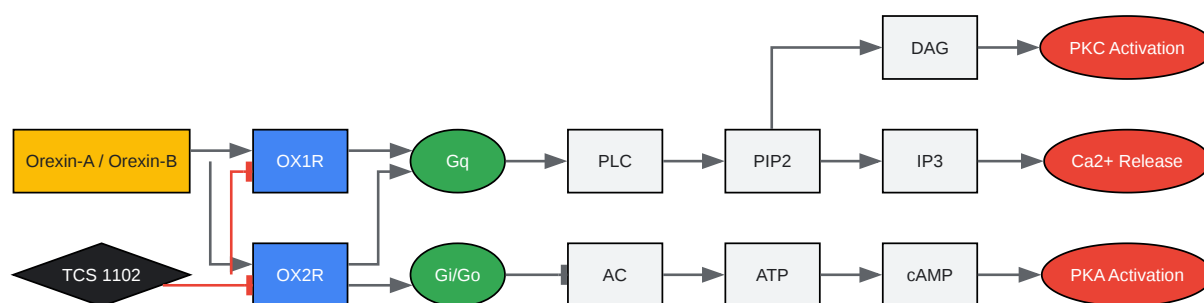

[Click to download full resolution via product page](#)

Caption: Simplified Orexin Signaling Pathway and the inhibitory action of **TCS 1102**.

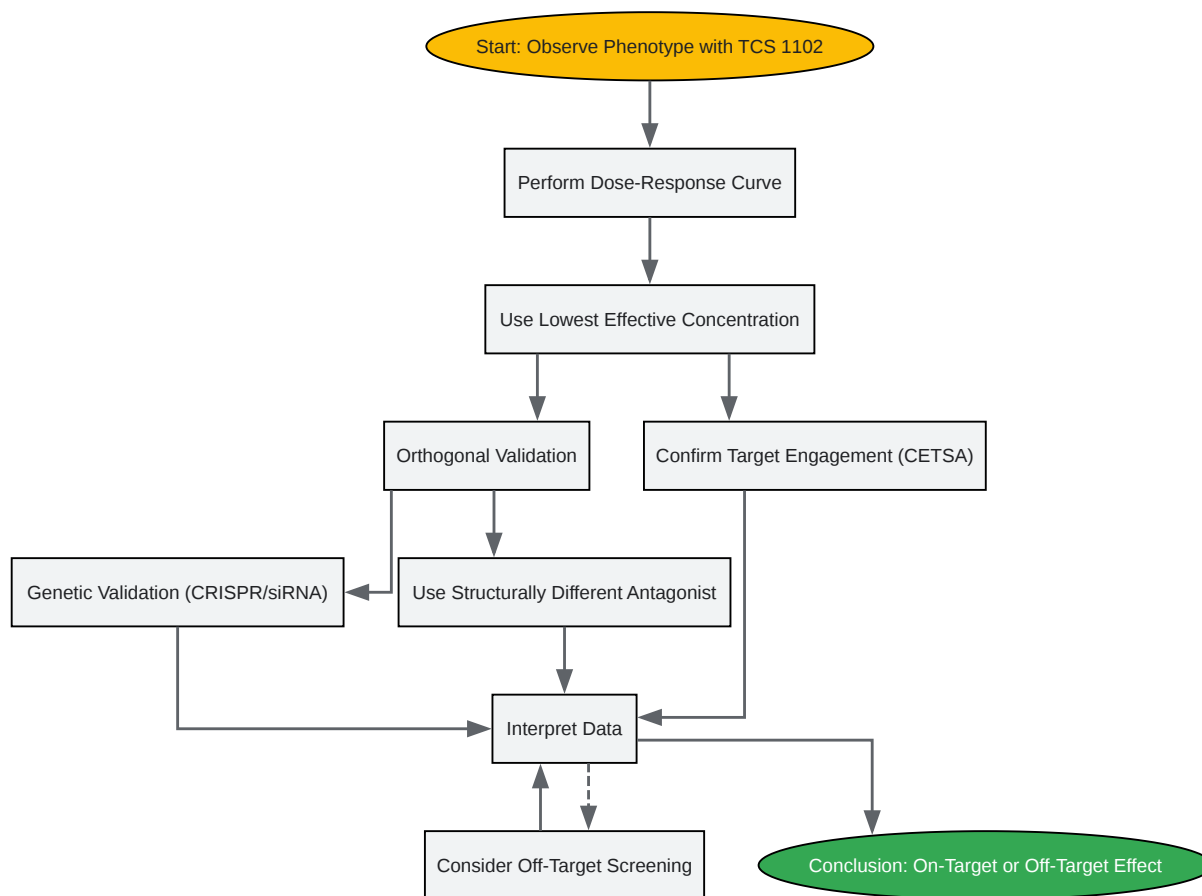

[Click to download full resolution via product page](#)

Caption: Experimental workflow for identifying and validating off-target effects of **TCS 1102**.

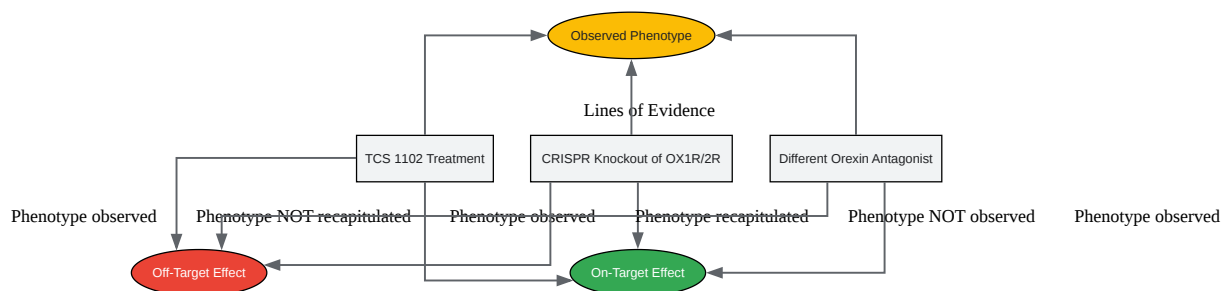

[Click to download full resolution via product page](#)

Caption: Logical relationship for determining on-target vs. off-target effects.

Need Custom Synthesis?

BenchChem offers custom synthesis for rare earth carbides and specific isotopic labeling.

Email: info@benchchem.com or [Request Quote Online](#).

References

- 1. [benchchem.com](https://www.benchchem.com) [benchchem.com]
- 2. Screening for Target Engagement using the Cellular Thermal Shift Assay - CETSA - Assay Guidance Manual - NCBI Bookshelf [ncbi.nlm.nih.gov]
- 3. TCS 1102 - Immunomart [immunomart.com]
- 4. rndsystems.com [rndsystems.com]
- 5. caymanchem.com [caymanchem.com]
- 6. labshake.com [labshake.com]
- 7. medchemexpress.com [medchemexpress.com]
- To cite this document: BenchChem. [Technical Support Center: Minimizing Off-Target Effects of TCS 1102]. BenchChem, [2026]. [Online PDF]. Available at:

[\[https://www.benchchem.com/product/b15618917/docs#technical-support-center-minimizing-off-target-effects-of-tcs-1102\]](https://www.benchchem.com/product/b15618917/docs#technical-support-center-minimizing-off-target-effects-of-tcs-1102)

Disclaimer & Data Validity:

The information provided in this document is for Research Use Only (RUO) and is strictly not intended for diagnostic or therapeutic procedures. While BenchChem strives to provide accurate protocols, we make no warranties, express or implied, regarding the fitness of this product for every specific experimental setup.

Technical Support: The protocols provided are for reference purposes. Unsure if this reagent suits your experiment?

Need Industrial/Bulk Grade? [Request Custom Synthesis Quote](#)

BenchChem

Our mission is to be the trusted global source of essential and advanced chemicals, empowering scientists and researchers to drive progress in science and industry.

Contact

Address: 3281 E Guasti Rd
Ontario, CA 91761, United States
Phone: (601) 213-4426
Email: info@benchchem.com

[Contact our Ph.D. Support Team for a compatibility check](#)