

Application Notes and Protocols for Calcium Imaging Assays with BTT-266

Author: BenchChem Technical Support Team. **Date:** April 2026

Compound of Interest

Compound Name: BTT-266
Cat. No.: B15618137

[Get Quote](#)

Introduction

BTT-266 is a novel small molecule inhibitor targeting key cellular signaling pathways implicated in oncogenesis. This document provides detailed application notes and protocols for utilizing calcium imaging assays to characterize the activity of **BTT-266** in live cells. Intracellular calcium (Ca^{2+}) is a ubiquitous second messenger that governs a multitude of cellular processes, including proliferation, differentiation, and apoptosis.[1] Dysregulation of Ca^{2+} signaling is a hallmark of various pathologies, including cancer. Calcium imaging serves as a powerful tool to investigate how novel therapeutics like **BTT-266** modulate these signaling events.

These protocols are intended for researchers, scientists, and drug development professionals engaged in the characterization of novel therapeutic compounds.

Principle of the Assay

This assay quantifies changes in intracellular calcium concentration in response to **BTT-266** treatment. Cells are loaded with a fluorescent calcium indicator dye, which exhibits an increase in fluorescence intensity upon binding to free Ca^{2+} . By monitoring the fluorescence changes over time using fluorescence microscopy or a plate reader, the inhibitory effect of **BTT-266** on signaling pathways that modulate intracellular calcium can be determined. A common approach

involves stimulating a G-protein coupled receptor (GPCR) that leads to the release of calcium from intracellular stores, and then assessing the ability of **BTT-266** to inhibit this response.

Data Presentation

The following tables represent typical quantitative data obtained from calcium imaging assays with **BTT-266**.

Table 1: Dose-Response of **BTT-266** on Intracellular Calcium Mobilization

BTT-266 Concentration (nM)	Peak Fluorescence Intensity (RFU)	% Inhibition
0 (Vehicle)	55,000	0
1	48,000	12.7
10	35,000	36.4
100	18,000	67.3
1000	8,000	85.5
10000	5,500	90.0

RFU: Relative Fluorescence Units

Table 2: Comparative Analysis of **BTT-266** with a Reference Inhibitor

Compound	IC50 (nM)	Maximum Inhibition (%)
BTT-266	85	92
Reference Inhibitor X	120	88

Experimental Protocols

Materials and Reagents

- Human cancer cell line expressing a relevant GPCR (e.g., HEK293, HeLa, or a cancer-specific line)
- Cell culture medium (e.g., DMEM) supplemented with 10% fetal bovine serum (FBS) and 1% penicillin-streptomycin
- **BTT-266** stock solution (e.g., 10 mM in DMSO)
- Fluorescent calcium indicator dye (e.g., Fluo-4 AM, Fura-2 AM)
- Pluronic F-127
- Hanks' Balanced Salt Solution (HBSS) with 20 mM HEPES
- GPCR agonist (e.g., ATP, Bradykinin)
- Black, clear-bottom 96-well microplates
- Fluorescence microplate reader or fluorescence microscope equipped with a camera and appropriate filters

Experimental Workflow

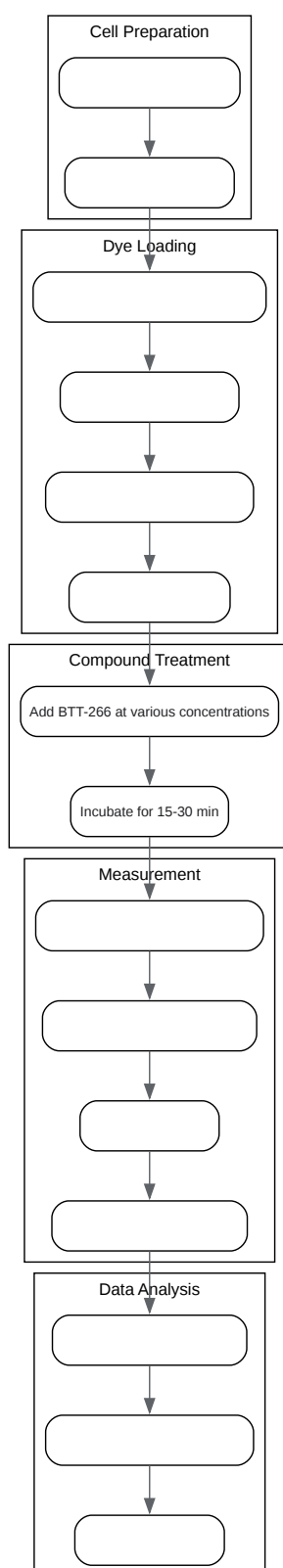

[Click to download full resolution via product page](#)

Caption: Experimental workflow for the calcium imaging assay with **BTT-266**.

Step-by-Step Protocol

- Cell Seeding:
 1. Harvest and count cells.
 2. Seed the cells into a black, clear-bottom 96-well microplate at a density of 40,000-80,000 cells per well in 100 μ L of complete culture medium.
 3. Incubate the plate at 37°C in a 5% CO₂ incubator for 24-48 hours to allow for cell attachment and formation of a monolayer.
- Calcium Indicator Dye Loading:
 1. Prepare a 2X Fluo-4 AM loading solution in HBSS. For example, for a final concentration of 4 μ M Fluo-4 AM and 0.04% Pluronic F-127, mix equal volumes of 8 μ M Fluo-4 AM and 0.08% Pluronic F-127 in HBSS.
 2. Aspirate the culture medium from the cell plate and add 100 μ L of the 2X Fluo-4 AM loading solution to each well.
 3. Incubate the plate at 37°C for 30-60 minutes.
 4. Wash the cells twice with 100 μ L of HBSS, leaving 100 μ L of HBSS in each well after the final wash.
- Compound Treatment:
 1. Prepare serial dilutions of **BTT-266** in HBSS at 2X the final desired concentrations.
 2. Add 100 μ L of the **BTT-266** dilutions to the corresponding wells of the cell plate. For vehicle control wells, add 100 μ L of HBSS containing the same percentage of DMSO.
 3. Incubate the plate at room temperature or 37°C for 15-30 minutes.
- Fluorescence Measurement:

1. Place the microplate into a fluorescence plate reader or on the stage of a fluorescence microscope.
 2. Set the instrument to record fluorescence at an excitation wavelength of ~494 nm and an emission wavelength of ~516 nm.
 3. Record a baseline fluorescence reading for 10-20 seconds.
 4. Add the GPCR agonist at a predetermined concentration (e.g., EC80) to all wells simultaneously using an automated dispenser.
 5. Continue recording the fluorescence intensity for an additional 1-2 minutes to capture the peak calcium response.
- Data Analysis:
 1. For each well, calculate the peak fluorescence response by subtracting the baseline fluorescence from the maximum fluorescence intensity after agonist addition.
 2. Normalize the data to the vehicle control wells (0% inhibition) and a positive control inhibitor or no-agonist control (100% inhibition).
 3. Plot the percent inhibition as a function of **BTT-266** concentration and fit the data to a four-parameter logistic equation to determine the IC50 value.

Signaling Pathway and Mechanism of Action

BTT-266 is hypothesized to inhibit the Wnt/ β -catenin signaling pathway. In the canonical Wnt pathway, the binding of a Wnt ligand to its receptor complex leads to the stabilization and nuclear translocation of β -catenin, which then activates target gene transcription. This pathway can also influence intracellular calcium levels through non-canonical signaling branches. **BTT-266** may act by preventing the release of calcium from the endoplasmic reticulum, which is a key event in Wnt-induced calcium signaling.

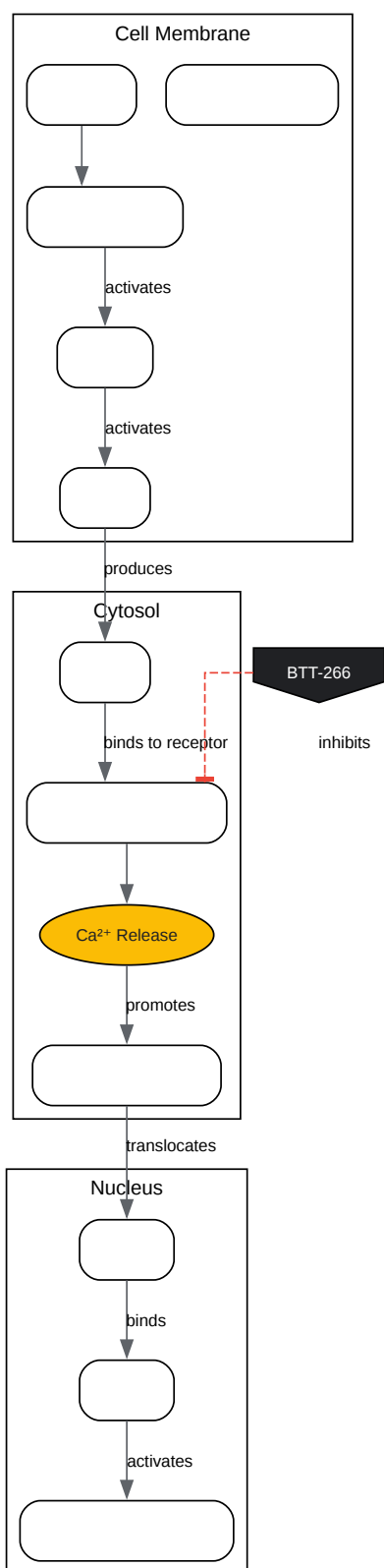

[Click to download full resolution via product page](#)

Caption: Hypothesized mechanism of **BTT-266** in the Wnt signaling pathway.

Logical Relationship Diagram

The inhibitory action of **BTT-266** on the Wnt signaling pathway can be logically represented as a disruption of the cascade that leads to an increase in intracellular calcium.

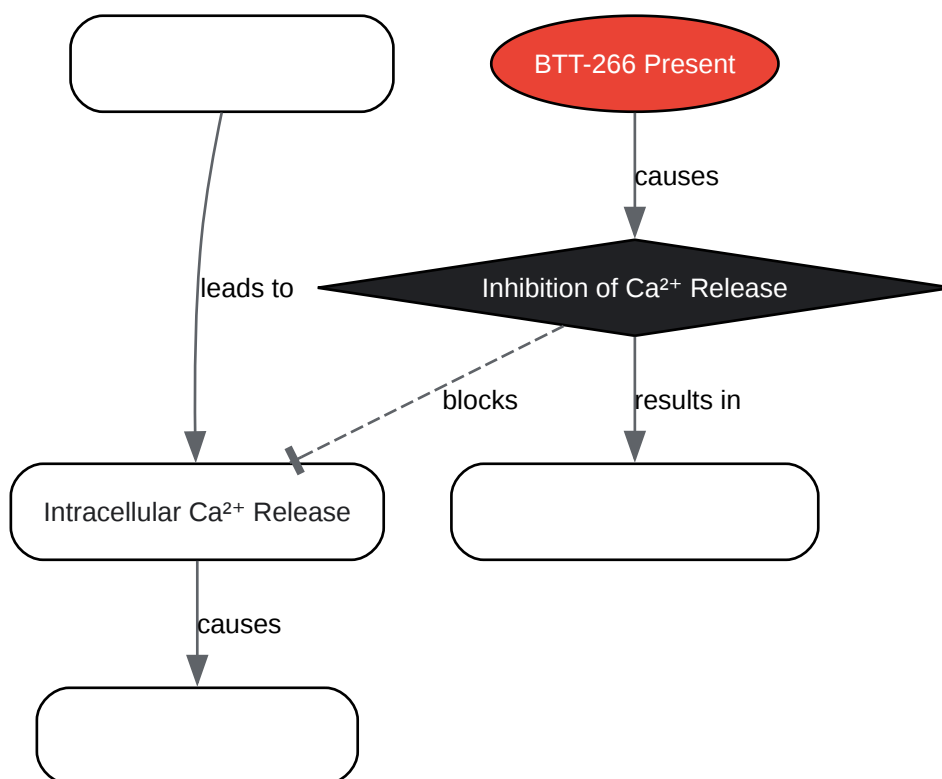

[Click to download full resolution via product page](#)

Caption: Logical diagram of **BTT-266**'s inhibitory effect on calcium signaling.

Need Custom Synthesis?

BenchChem offers custom synthesis for rare earth carbides and specific isotopic labeling.

Email: info@benchchem.com or [Request Quote Online](#).

References

- 1. [Image Analysis of Ca²⁺ Signals as a Basis for Neurotoxicity Assays: Promises and Challenges - PMC \[pmc.ncbi.nlm.nih.gov\]](#)

- To cite this document: BenchChem. [Application Notes and Protocols for Calcium Imaging Assays with BTT-266]. BenchChem, [2026]. [Online PDF]. Available at: [<https://www.benchchem.com/product/b15618137/docs#application-notes-and-protocols-for-calcium-imaging-assays-with-btt-266>]

Disclaimer & Data Validity:

The information provided in this document is for Research Use Only (RUO) and is strictly not intended for diagnostic or therapeutic procedures. While BenchChem strives to provide accurate protocols, we make no warranties, express or implied, regarding the fitness of this product for every specific experimental setup.

Technical Support: The protocols provided are for reference purposes. Unsure if this reagent suits your experiment?

Need Industrial/Bulk Grade? [Request Custom Synthesis Quote](#)

BenchChem

Our mission is to be the trusted global source of essential and advanced chemicals, empowering scientists and researchers to drive progress in science and industry.

Contact

Address: 3281 E Guasti Rd
Ontario, CA 91761, United States
Phone: (601) 213-4426
Email: info@benchchem.com

[Contact our Ph.D. Support Team for a compatibility check](#)