

Application Notes and Protocols: DMX-129 in Combination Therapies

Author: BenchChem Technical Support Team. **Date:** April 2026

Compound of Interest

Compound Name: DMX-129
Cat. No.: B15618236

[Get Quote](#)

For Researchers, Scientists, and Drug Development Professionals

Introduction

DMX-129 is a potent, small-molecule dual inhibitor of the non-canonical I κ B kinases, TANK-binding kinase 1 (TBK1) and I κ B kinase ϵ (IKK ϵ), with reported IC₅₀ values below 30 nM for both enzymes.[1] These kinases are critical nodes in signaling pathways that regulate innate immunity, inflammatory responses, and cell survival. In various cancers, aberrant activation of TBK1 and IKK ϵ promotes oncogenic phenotypes, including proliferation, survival, and evasion of immune surveillance.[1] Inhibition of TBK1/IKK ϵ can therefore suppress tumor growth and, critically, sensitize cancer cells to other therapeutic agents.

These notes provide detailed application guidelines and experimental protocols for investigating **DMX-129** in combination with two key classes of anti-cancer drugs: immune checkpoint inhibitors and MEK inhibitors.

Signaling Pathway and Mechanism of Action

TBK1 and IKK ϵ are key downstream effectors of pattern recognition receptors (e.g., Toll-like receptors) and the cGAS-STING pathway, which senses cytosolic DNA. Upon activation, they

phosphorylate transcription factors such as Interferon Regulatory Factor 3 (IRF3) and IRF7, leading to the production of type I interferons (IFN-I).[2] They also play a role in activating the NF- κ B pathway and the AKT/mTOR signaling cascade, both of which are crucial for tumor cell survival and proliferation.[3]

By inhibiting TBK1 and IKK ϵ , **DMX-129** blocks these downstream effects. This can lead to reduced production of immunosuppressive cytokines, decreased tumor cell survival, and an altered tumor microenvironment that is more susceptible to immune attack.

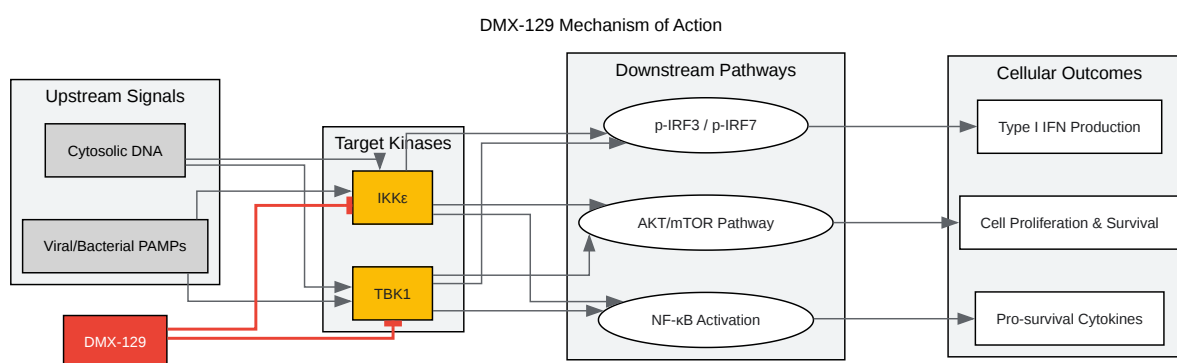

[Click to download full resolution via product page](#)

Fig. 1: **DMX-129** inhibits TBK1/IKK ϵ , blocking downstream pro-survival and immunomodulatory pathways.

Application Note 1: Combination with Immune Checkpoint Inhibitors

Rationale: Immune checkpoint inhibitors (ICIs), such as anti-PD-1 or anti-PD-L1 antibodies, rely on a pre-existing anti-tumor T-cell response. Many tumors, however, create an immunosuppressive microenvironment to evade immune destruction, rendering them "cold" and unresponsive to ICIs. TBK1/IKK ϵ activity in tumor cells can contribute to this resistance.

Inhibition of TBK1 with **DMX-129** has been shown to sensitize tumors to immune attack.[4] By blocking TBK1/IKK ϵ , **DMX-129** can lower the threshold for tumor cell killing by immune effector cytokines like TNF α and IFN γ . [2][4] This action can convert immunologically "cold" tumors into "hot" tumors that are responsive to checkpoint blockade. The combination of **DMX-129** and an anti-PD-1/PD-L1 agent is therefore a promising strategy to overcome immunotherapy resistance.[5]

Expected Synergistic Effects: The combination of **DMX-129** with an anti-PD-1 antibody is expected to produce greater tumor control than either agent alone. This can be monitored by observing tumor growth in vivo and analyzing key biomarkers in the tumor microenvironment.

Treatment Group	Tumor Growth Inhibition (%) (Illustrative)	Key Biomarker Changes in Tumor
Vehicle Control	0%	Baseline
DMX-129 (monotherapy)	25%	↓ p-TBK1, ↓ p-IRF3
Anti-PD-1 (monotherapy)	20%	↑ CD8+ T-cell infiltration
DMX-129 + Anti-PD-1	75%	↓ p-TBK1, ↓ p-IRF3, ↑↑ CD8+ T-cell infiltration, ↑ IFN γ , ↑ Granzyme B

Table 1: Representative data illustrating the expected synergy between **DMX-129** and anti-PD-1 therapy in a syngeneic mouse tumor model. Quantitative values are for illustrative purposes to demonstrate the anticipated synergistic effect.

Application Note 2: Combination with MEK Inhibitors

Rationale: The RAS-RAF-MEK-ERK (MAPK) pathway is frequently hyperactivated in many cancers due to mutations in genes like KRAS or BRAF. While MEK inhibitors (MEKi) can be effective, tumors often develop resistance through the activation of bypass signaling pathways, one of which is the PI3K/AKT/mTOR pathway.[3][6] Since TBK1 and IKK ϵ are known to activate AKT, their inhibition presents a rational strategy to block this escape route.[7]

Simultaneously targeting both the MEK and TBK1/IKKε pathways can create a potent synergistic anti-tumor effect, preventing the adaptive resistance that limits the efficacy of MEK inhibitor monotherapy.[8] This combination is particularly relevant for tumors with known RAS pathway mutations.

Expected Synergistic Effects: The combination of **DMX-129** and a MEK inhibitor (e.g., Trametinib) is expected to show strong synergy in cancer cell lines, particularly those with KRAS mutations. This can be quantified by measuring cell viability and calculating a Combination Index (CI), where a value < 1 indicates synergy.

Cell Line (Mutation)	Treatment	IC50 (nM) (Illustrative)	Combination Index (CI) (Illustrative)
HCT116 (KRAS G13D)	DMX-129	25	-
	Trametinib	10	-
DMX-129 + Trametinib	DMX-129: 5, Trametinib: 2	0.4 (Strong Synergy)	
SW620 (KRAS G12V)	DMX-129	30	-
	Trametinib	15	-
DMX-129 + Trametinib	DMX-129: 7, Trametinib: 3.5	0.5 (Synergy)	

Table 2: Representative cell viability data illustrating the expected synergistic interaction between **DMX-129** and a MEK inhibitor in KRAS-mutant colorectal cancer cell lines. IC50 and CI values are for illustrative purposes. A CI value < 1 indicates a synergistic effect.

Experimental Protocols

Workflow: In Vitro Synergy Assessment

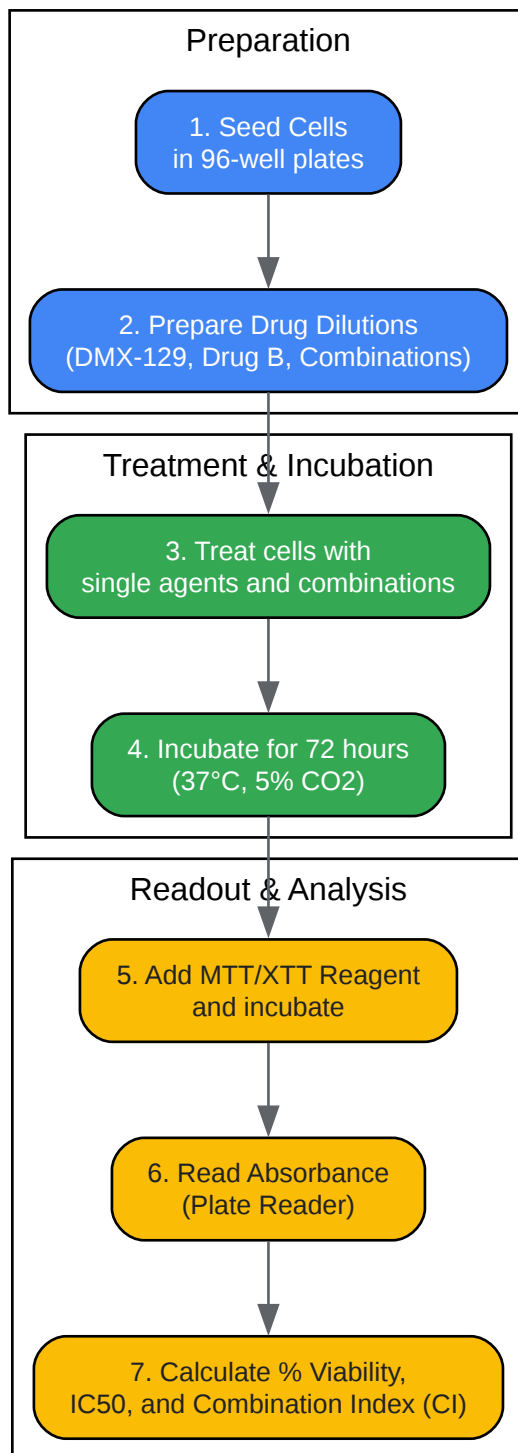

[Click to download full resolution via product page](#)

Fig. 2: Experimental workflow for determining the synergistic effects of **DMX-129** in combination with another drug.

Protocol 1: In Vitro Synergy Assessment (MTT/XTT Cell Viability Assay)

This protocol outlines a method to determine if the combination of **DMX-129** and a second drug (Drug B) results in a synergistic, additive, or antagonistic effect on cancer cell proliferation.

Materials:

- Cancer cell line of interest
- 96-well flat-bottom cell culture plates
- Complete growth medium (e.g., DMEM/RPMI + 10% FBS)
- **DMX-129** and Drug B, dissolved in DMSO to create high-concentration stocks
- MTT (3-(4,5-dimethylthiazol-2-yl)-2,5-diphenyltetrazolium bromide) or XTT reagent kit
- DMSO (for formazan solubilization in MTT assay)
- Multichannel pipette
- Microplate reader

Procedure:

- Cell Seeding:
 - Trypsinize and count cells that are in the logarithmic growth phase.
 - Resuspend cells in complete medium and seed them into 96-well plates at a pre-determined optimal density (e.g., 2,000-10,000 cells/well in 100 μ L).
 - Incubate the plates for 24 hours at 37°C, 5% CO₂ to allow cells to attach.
- Drug Preparation and Treatment:

- Prepare serial dilutions of **DMX-129** and Drug B in complete medium. A common approach is a 6x6 or 7x7 matrix.
- For combination treatments, prepare mixtures of **DMX-129** and Drug B at a constant ratio (e.g., based on the ratio of their individual IC50 values).
- Carefully remove the medium from the cells and add 100 μ L of the medium containing the appropriate drug concentrations (single agents, combinations, or vehicle control).
- Include wells with medium only (no cells) for blank correction.
- Incubation:
 - Return the plates to the incubator and incubate for 72 hours at 37°C, 5% CO₂.
- Viability Measurement (MTT Assay Example):
 - Add 10 μ L of MTT solution (5 mg/mL in PBS) to each well.
 - Incubate for 3-4 hours at 37°C until purple formazan crystals are visible.
 - Carefully aspirate the medium and add 100 μ L of DMSO to each well to dissolve the crystals. Mix gently by pipetting.
- Data Acquisition and Analysis:
 - Read the absorbance at 570 nm using a microplate reader.
 - Subtract the average absorbance of the blank wells from all other values.
 - Calculate the percentage of cell viability for each treatment relative to the vehicle-treated control wells.
 - Use software like GraphPad Prism to calculate IC50 values for each drug.
 - Use software like CompuSyn to calculate the Combination Index (CI) based on the Chou-Talalay method.^[9] A CI < 1 indicates synergy, CI = 1 indicates an additive effect, and CI > 1 indicates antagonism.

Protocol 2: Western Blot Analysis of Pathway Modulation

This protocol is used to confirm that **DMX-129**, alone or in combination, is inhibiting the intended signaling pathways.

Materials:

- 6-well cell culture plates
- RIPA buffer with protease and phosphatase inhibitors
- BCA Protein Assay Kit
- SDS-PAGE gels and running buffer
- PVDF membrane
- Transfer buffer and system
- Blocking buffer (e.g., 5% non-fat milk or BSA in TBST)
- Primary antibodies (e.g., anti-p-TBK1, anti-TBK1, anti-p-AKT, anti-AKT, anti-p-ERK, anti-ERK, anti-GAPDH)
- HRP-conjugated secondary antibodies
- Enhanced Chemiluminescence (ECL) substrate
- Imaging system

Procedure:

- Cell Treatment and Lysis:
 - Seed cells in 6-well plates and grow to 70-80% confluency.

- Treat cells with **DMX-129**, Drug B, the combination, or vehicle control for a specified time (e.g., 1, 6, or 24 hours).
- Wash cells with ice-cold PBS and lyse them directly in the plate with 100-150 μ L of ice-cold RIPA buffer.
- Scrape the cells, transfer the lysate to a microfuge tube, and centrifuge at 14,000 rpm for 15 minutes at 4°C.
- Collect the supernatant (protein lysate).
- Protein Quantification:
 - Determine the protein concentration of each lysate using a BCA assay according to the manufacturer's instructions.
- SDS-PAGE and Transfer:
 - Normalize protein amounts for all samples (e.g., 20-30 μ g per lane) and add Laemmli sample buffer. Boil for 5 minutes.
 - Load samples onto an SDS-PAGE gel and run until the dye front reaches the bottom.
 - Transfer the proteins from the gel to a PVDF membrane.
- Immunoblotting:
 - Block the membrane with blocking buffer for 1 hour at room temperature.
 - Incubate the membrane with the desired primary antibody (diluted in blocking buffer) overnight at 4°C with gentle agitation.
 - Wash the membrane three times for 10 minutes each with TBST.
 - Incubate with the appropriate HRP-conjugated secondary antibody for 1 hour at room temperature.
 - Wash the membrane again three times for 10 minutes each with TBST.

- Detection:
 - Apply ECL substrate to the membrane and capture the chemiluminescent signal using an imaging system.
 - Analyze the band intensities, normalizing phosphorylated proteins to their total protein counterparts and then to a loading control like GAPDH.

Protocol 3: In Vivo Xenograft/Syngeneic Model Study

This protocol provides a general framework for evaluating the in vivo efficacy of **DMX-129** in combination therapy using a mouse tumor model. For immunotherapy combinations, a syngeneic model (immunocompetent mice) is required. For other combinations, a xenograft model (immunocompromised mice) can be used.[\[10\]](#)

Materials:

- Immunocompetent (e.g., C57BL/6) or immunocompromised (e.g., NOD/SCID) mice
- Tumor cells (syngeneic or human)
- **DMX-129** and Drug B formulated for in vivo administration
- Calipers for tumor measurement
- Sterile syringes and needles

Procedure:

- Tumor Implantation:
 - Inject a suspension of tumor cells (e.g., 1×10^6 cells in 100 μ L PBS/Matrigel) subcutaneously into the flank of each mouse.[\[10\]](#)
 - Allow tumors to grow to a palpable size (e.g., 100-150 mm^3).
- Randomization and Treatment:
 - Measure tumor volumes using calipers (Volume = $0.5 \times \text{Length} \times \text{Width}^2$).

- Randomize mice into treatment groups (e.g., n=8-10 mice per group):
 - Group 1: Vehicle Control
 - Group 2: **DMX-129**
 - Group 3: Drug B
 - Group 4: **DMX-129** + Drug B
- Administer drugs according to a predetermined dosing schedule (e.g., daily oral gavage for **DMX-129**, weekly intraperitoneal injection for an antibody).
- Monitoring and Endpoints:
 - Monitor animal body weight and general health status 2-3 times per week as an indicator of toxicity.
 - Measure tumor volumes with calipers 2-3 times per week.
 - Continue treatment until tumors in the control group reach a predetermined endpoint size (e.g., 1500-2000 mm³), or for a set duration.
 - Primary endpoints are typically tumor growth inhibition (TGI) and survival analysis.
- Data Analysis:
 - Plot the mean tumor volume \pm SEM for each group over time.
 - Calculate the percent TGI for each treatment group compared to the vehicle control.
 - Perform statistical analysis (e.g., ANOVA or t-test) to determine the significance of the combination therapy compared to monotherapies.[11]
 - If applicable, generate Kaplan-Meier survival curves and perform log-rank tests.
 - At the end of the study, tumors can be harvested for pharmacodynamic analysis (e.g., Western blot or immunohistochemistry).

Need Custom Synthesis?

BenchChem offers custom synthesis for rare earth carbides and specific isotopic labeling.

Email: info@benchchem.com or [Request Quote Online](#).

References

- 1. Protocol for Cell Viability Assays: CCK-8 and MTT - Creative Biogene [creative-biogene.com]
- 2. Targeting TBK1 to overcome resistance to cancer immunotherapy - PubMed [pubmed.ncbi.nlm.nih.gov]
- 3. Beyond single pathway inhibition: MEK inhibitors as a platform for the development of pharmacological combinations with synergistic anti-leukemic effects - PubMed [pubmed.ncbi.nlm.nih.gov]
- 4. Targeting TBK1 to overcome resistance to cancer immunotherapy - PMC [pmc.ncbi.nlm.nih.gov]
- 5. TBK1 as promising new therapeutic target to overcome cancer immunotherapy resistance | BioWorld [bioworld.com]
- 6. Synergistic inhibition of MEK and reciprocal feedback networks for targeted intervention in malignancy - PMC [pmc.ncbi.nlm.nih.gov]
- 7. Selective TBK1/IKKi dual inhibitors with anti-cancer potency - PMC [pmc.ncbi.nlm.nih.gov]
- 8. researchgate.net [researchgate.net]
- 9. 4.2. Cell Viability Assays and Drug Combination Studies [bio-protocol.org]
- 10. In vivo Efficacy Studies in Cell Line and Patient-derived Xenograft Mouse Models - PMC [pmc.ncbi.nlm.nih.gov]
- 11. aacrjournals.org [aacrjournals.org]
- To cite this document: BenchChem. [Application Notes and Protocols: DMX-129 in Combination Therapies]. BenchChem, [2026]. [Online PDF]. Available at: [<https://www.benchchem.com/product/b15618236/docs#application-notes-and-protocols-dmx-129-in-combination-therapies>]

Disclaimer & Data Validity:

The information provided in this document is for Research Use Only (RUO) and is strictly not intended for diagnostic or therapeutic procedures. While BenchChem strives to provide accurate protocols, we make no warranties, express or implied, regarding the fitness of this product for every specific experimental setup.

Technical Support: The protocols provided are for reference purposes. Unsure if this reagent suits your experiment?

Need Industrial/Bulk Grade? [Request Custom Synthesis Quote](#)

BenchChem

Our mission is to be the trusted global source of essential and advanced chemicals, empowering scientists and researchers to drive progress in science and industry.

Contact

Address: 3281 E Guasti Rd
Ontario, CA 91761, United States
Phone: (601) 213-4426
Email: info@benchchem.com

[Contact our Ph.D. Support Team for a compatibility check](#)