

Technical Support Center: Ynt-185 & OX2R Selectivity

Author: BenchChem Technical Support Team. **Date:** April 2026

Compound of Interest

Compound Name: Ynt-185
Cat. No.: B15617110

[Get Quote](#)

Welcome to the technical support center for **Ynt-185**, a selective orexin 2 receptor (OX2R) agonist. This resource is designed for researchers, scientists, and drug development professionals to provide guidance on experiments aimed at characterizing and enhancing the selectivity of **Ynt-185** for OX2R.

Frequently Asked Questions (FAQs)

Q1: What is the reported selectivity of **Ynt-185** for OX2R over OX1R?

A1: **Ynt-185** is a nonpeptide, selective OX2R agonist.^{[1][2][3][4]} It demonstrates approximately 100-fold selectivity for the human OX2R over the human OX1R.^{[3][5]}

Q2: In what cell lines have **Ynt-185**'s activity and selectivity been validated?

A2: The activity of **Ynt-185** has been evaluated in Chinese hamster ovary (CHO) cells stably expressing either human OX1R (CHO/hOX1R) or human OX2R (CHO/hOX2R).^{[3][5]}

Q3: What are the key signaling pathways activated by OX2R?

A3: Orexin receptors, including OX2R, are G-protein coupled receptors (GPCRs).[6][7] Upon agonist binding, OX2R can couple to Gq, Gi/o, and Gs proteins.[6][8] This activation can lead to downstream effects such as mobilization of intracellular Ca²⁺, modulation of adenylyl cyclase activity, and activation of the ERK1/2 signaling cascade.[5][8][9]

Q4: Has **Ynt-185** shown efficacy in in vivo models?

A4: Yes, peripherally administered **Ynt-185** has been shown to cross the blood-brain barrier.[5][10] It has demonstrated the ability to suppress cataplexy-like episodes and promote wakefulness in mouse models of narcolepsy.[4][5][10][11] However, some studies note its limited efficacy in fully ameliorating wake fragmentation compared to other agonists, possibly due to differences in potency.[12][13]

Troubleshooting Guides

This section addresses specific issues that may arise during experiments with **Ynt-185**.

Issue 1: Lower than Expected OX2R Potency (High EC50 Value)

Possible Causes & Solutions:

- Compound Integrity:
 - Question: Has the integrity of the **Ynt-185** compound been verified?
 - Solution: Ensure **Ynt-185** has been stored correctly, protected from light, at -20°C for short-term or -80°C for long-term storage.[1] Prepare fresh working solutions for each experiment.[1] Consider verifying the compound's purity and identity via analytical methods like HPLC or mass spectrometry.
- Cell Health and Receptor Expression:
 - Question: Are the CHO-hOX2R cells healthy and expressing the receptor at sufficient levels?

- Solution: Regularly check cell viability and morphology. Perform quality control, such as Western blot or qPCR, to confirm stable expression of hOX2R in your cell line. Passage cells for a limited number of times to avoid genetic drift.
- Assay Conditions:
 - Question: Are the assay buffer components and incubation times optimal?
 - Solution: Ensure the assay buffer composition is appropriate for GPCR functional assays. Optimize incubation time to ensure the binding reaction reaches equilibrium.[\[14\]](#)

Issue 2: Poor Selectivity Observed (Significant OX1R Activation)

Possible Causes & Solutions:

- Compound Concentration:
 - Question: Is the concentration of **Ynt-185** used too high?
 - Solution: While **Ynt-185** is selective, at very high concentrations it may start to activate OX1R.[\[1\]](#)[\[3\]](#)[\[5\]](#) Perform a full dose-response curve to determine the optimal concentration range that maintains selectivity.
- Receptor Expression Levels:
 - Question: Could overexpression of OX1R in the cell system be masking the selectivity?
 - Solution: Use cell lines with well-characterized and comparable expression levels of OX1R and OX2R for direct comparison. High levels of receptor overexpression can sometimes lead to non-specific effects.
- Assay Sensitivity:
 - Question: Is the functional assay for OX1R activation more sensitive than the one for OX2R?

- Solution: Ensure that the downstream readouts for both receptor assays (e.g., Ca²⁺ mobilization) are comparable in their dynamic range and sensitivity. Use a reference dual agonist to normalize the responses between the two receptor subtypes.

Quantitative Data Summary

Compound	Receptor	EC50	Cell Line	Assay Type	Reference
Ynt-185	hOX2R	28 nM	CHO	Intracellular Ca ²⁺ Mobilization	[3] [5]
Ynt-185	hOX1R	2.75 μM	CHO	Intracellular Ca ²⁺ Mobilization	[1] [3] [5]
Orexin-A	hOX1R	0.50 nM	CHO	Intracellular Ca ²⁺ Mobilization	[12]
Orexin-A	hOX2R	0.20 nM	CHO	Intracellular Ca ²⁺ Mobilization	[12]
AL-OXB	hOX1R	58 nM	CHO	Intracellular Ca ²⁺ Mobilization	[12]
AL-OXB	hOX2R	0.055 nM	CHO	Intracellular Ca ²⁺ Mobilization	[12]

Key Experimental Protocols

Protocol 1: In Vitro Intracellular Calcium Mobilization Assay

This protocol is used to determine the potency (EC₅₀) of **Ynt-185** at hOX1R and hOX2R.

Methodology:

- **Cell Culture:** Culture CHO cells stably expressing either hOX1R or hOX2R in appropriate media and conditions.
- **Cell Plating:** Seed the cells into 96-well or 384-well black, clear-bottom microplates and allow them to adhere overnight.
- **Dye Loading:** Wash the cells with an assay buffer (e.g., Hanks' Balanced Salt Solution with 20 mM HEPES). Load the cells with a calcium-sensitive fluorescent dye (e.g., Fluo-4 AM) according to the manufacturer's instructions.
- **Compound Preparation:** Prepare a serial dilution of **Ynt-185** in the assay buffer.
- **Assay Execution:** Use a fluorescence plate reader (e.g., FLIPR or FlexStation) to measure the baseline fluorescence. Add the **Ynt-185** dilutions to the wells and monitor the change in fluorescence intensity over time, which corresponds to the intracellular Ca²⁺ concentration.
- **Data Analysis:** For each concentration, calculate the peak fluorescence response. Plot the response against the logarithm of the **Ynt-185** concentration and fit the data to a four-parameter logistic equation to determine the EC₅₀ value.

Protocol 2: Radioligand Binding Assay (Competitive)

This protocol can be used to determine the binding affinity (K_i) of **Ynt-185**.

Methodology:

- **Membrane Preparation:** Prepare cell membranes from CHO cells expressing either hOX1R or hOX2R.
- **Assay Setup:** In a microplate, combine the cell membranes, a fixed concentration of a suitable radiolabeled orexin receptor antagonist (e.g., [3H]-Suvorexant), and varying concentrations of unlabeled **Ynt-185**.
- **Incubation:** Incubate the mixture to allow the binding to reach equilibrium. The time and temperature must be optimized for the specific receptor and radioligand.[\[14\]](#)
- **Separation:** Separate the bound from unbound radioligand using rapid vacuum filtration through a glass fiber filter.

- Detection: Measure the radioactivity retained on the filters using a scintillation counter.
- Data Analysis: Plot the percentage of specific binding against the logarithm of the **Ynt-185** concentration. Fit the data to a one-site competition model to determine the IC50 value. Calculate the Ki value using the Cheng-Prusoff equation.

Visualizations

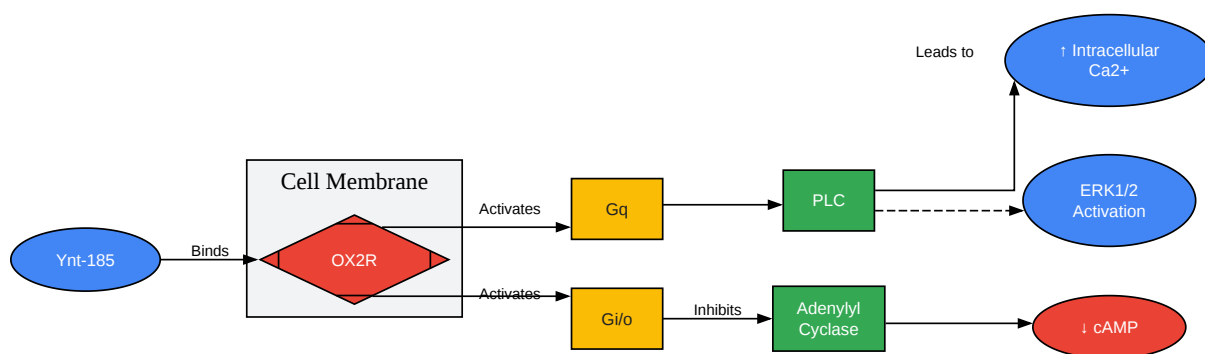

[Click to download full resolution via product page](#)

Caption: Simplified OX2R signaling cascade upon **Ynt-185** binding.

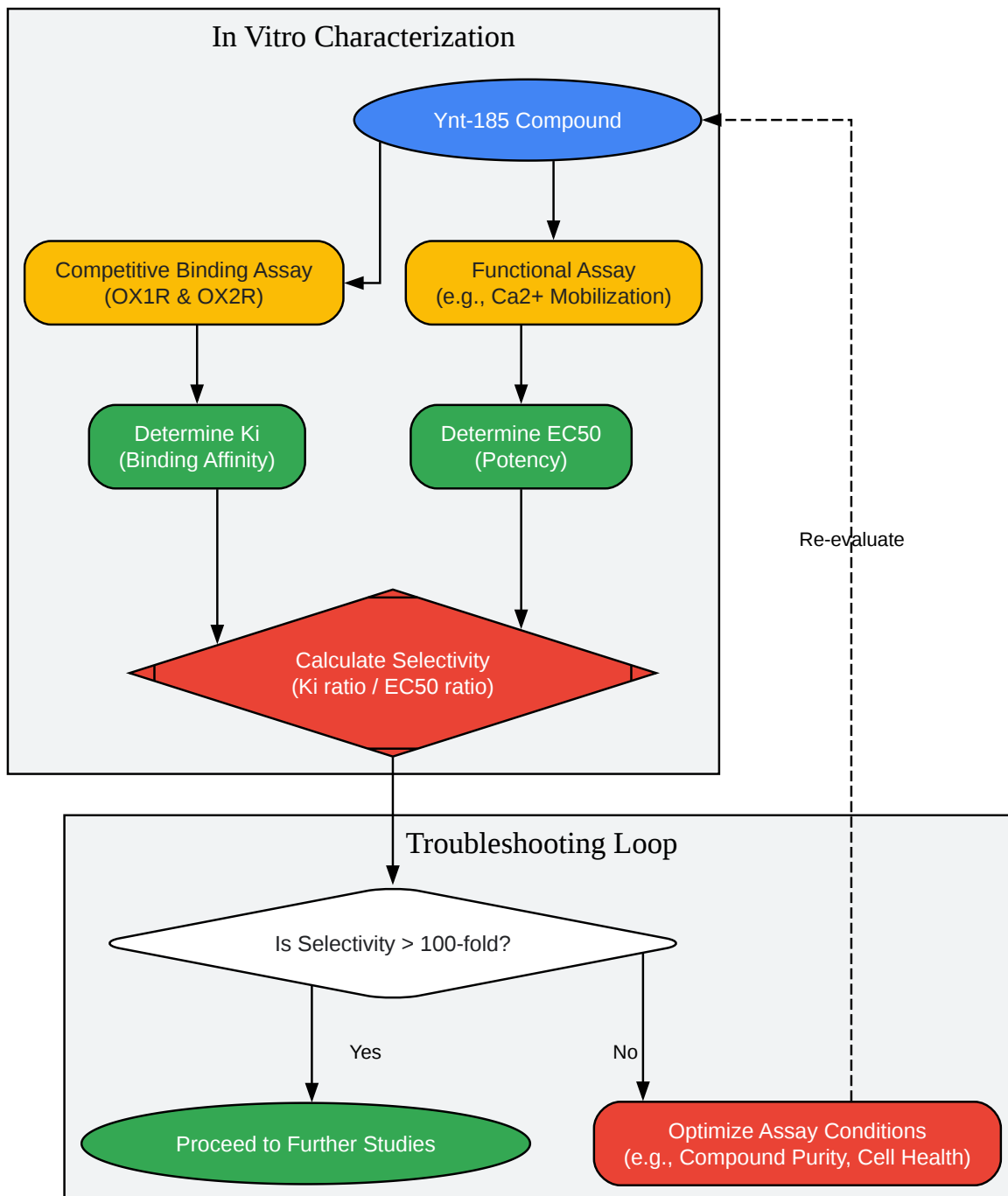

[Click to download full resolution via product page](#)

Caption: Workflow for determining and troubleshooting **Ynt-185** selectivity.

Need Custom Synthesis?

BenchChem offers custom synthesis for rare earth carbides and specific isotopic labeling.

Email: info@benchchem.com or [Request Quote Online](#).

References

- [1. medchemexpress.com \[medchemexpress.com\]](https://www.medchemexpress.com)
- [2. From orexin receptor agonist YNT-185 to novel antagonists with drug-like properties for the treatment of insomnia - PubMed \[pubmed.ncbi.nlm.nih.gov\]](#)
- [3. YNT 185 | OX2 Receptors | Tocris Bioscience \[tocris.com\]](https://www.tocris.com)
- [4. Nonpeptide orexin type-2 receptor agonist ameliorates narcolepsy-cataplexy symptoms in mouse models - PubMed \[pubmed.ncbi.nlm.nih.gov\]](#)
- [5. Nonpeptide orexin type-2 receptor agonist ameliorates narcolepsy-cataplexy symptoms in mouse models - PMC \[pmc.ncbi.nlm.nih.gov\]](#)
- [6. The Orexin/Receptor System: Molecular Mechanism and Therapeutic Potential for Neurological Diseases - PMC \[pmc.ncbi.nlm.nih.gov\]](#)
- [7. What are OX2R agonists and how do they work? \[synapse.patsnap.com\]](https://www.synapse.patsnap.com)
- [8. Frontiers | Orexin Signaling: A Complex, Multifaceted Process \[frontiersin.org\]](https://www.frontiersin.org)
- [9. A molecular network map of orexin-orexin receptor signaling system - PMC \[pmc.ncbi.nlm.nih.gov\]](#)
- [10. sleepreviewmag.com \[sleepreviewmag.com\]](https://www.sleepreviewmag.com)
- [11. Evaluation of the Efficacy of the Hypocretin/orexin Receptor Agonists TAK-925 and ARN-776 in Narcoleptic Orexin/tTA; TetO-DTA Mice - PMC \[pmc.ncbi.nlm.nih.gov\]](#)
- [12. OX2R-selective orexin agonism is sufficient to ameliorate cataplexy and sleep/wake fragmentation without inducing drug-seeking behavior in mouse model of narcolepsy - PMC \[pmc.ncbi.nlm.nih.gov\]](#)
- [13. OX2R-selective orexin agonism is sufficient to ameliorate cataplexy and sleep/wake fragmentation without inducing drug-seeking behavior in mouse model of narcolepsy | PLOS One \[journals.plos.org\]](#)
- [14. Approaches to Assess Functional Selectivity in GPCRs: Evaluating G Protein Signaling in an Endogenous Environment - PMC \[pmc.ncbi.nlm.nih.gov\]](#)

- To cite this document: BenchChem. [Technical Support Center: Ynt-185 & OX2R Selectivity]. BenchChem, [2026]. [Online PDF]. Available at: [<https://www.benchchem.com/product/b15617110/docs#technical-support-center-ynt-185-ox2r-selectivity>]

Disclaimer & Data Validity:

The information provided in this document is for Research Use Only (RUO) and is strictly not intended for diagnostic or therapeutic procedures. While BenchChem strives to provide accurate protocols, we make no warranties, express or implied, regarding the fitness of this product for every specific experimental setup.

Technical Support: The protocols provided are for reference purposes. Unsure if this reagent suits your experiment?

Need Industrial/Bulk Grade? [Request Custom Synthesis Quote](#)

BenchChem

Our mission is to be the trusted global source of essential and advanced chemicals, empowering scientists and researchers to drive progress in science and industry.

Contact

Address: 3281 E Guasti Rd
Ontario, CA 91761, United States
Phone: (601) 213-4426
Email: info@benchchem.com

[Contact our Ph.D. Support Team for a compatibility check](#)