

Technical Support Center: PF-06733804

Experimental Troubleshooting

Author: BenchChem Technical Support Team. **Date:** April 2026

Compound of Interest

Compound Name: PF-06733804

CAS No.: 1873373-33-1

Cat. No.: B15617577

[Get Quote](#)

This technical support center provides troubleshooting guides and frequently asked questions (FAQs) for researchers, scientists, and drug development professionals working with the pan-Trk inhibitor, **PF-06733804**.

Frequently Asked Questions (FAQs)

Q1: What is **PF-06733804** and what is its primary mechanism of action?

A1: **PF-06733804** is a potent, small molecule inhibitor of Tropomyosin receptor kinases (Trk). It acts as a pan-Trk inhibitor, meaning it targets all three members of the Trk receptor family: TrkA, TrkB, and TrkC. By binding to the ATP-binding site in the kinase domain of these receptors, **PF-06733804** blocks their phosphorylation and subsequent activation of downstream signaling pathways. This inhibition disrupts key cellular processes reliant on Trk signaling, such as cell growth, differentiation, and survival.

Q2: What are the reported IC50 values for **PF-06733804** against Trk receptors?

A2: In cell-based assays, **PF-06733804** has demonstrated potent inhibition of Trk receptors with the following half-maximal inhibitory concentrations (IC50):

Receptor	IC50 (nM)
TrkA	8.4
TrkB	6.2
TrkC	2.2

Q3: Which downstream signaling pathways are affected by **PF-06733804**?

A3: As a pan-Trk inhibitor, **PF-06733804** blocks the activation of the primary signaling cascades initiated by Trk receptors. These include the Ras/MAPK, PI3K/Akt, and PLC γ pathways. Inhibition of these pathways can lead to decreased cell proliferation, survival, and other cellular responses mediated by neurotrophins.

Q4: What are the recommended storage conditions for **PF-06733804**?

A4: For optimal stability, it is recommended to store the powdered form of **PF-06733804** at -20°C. Once dissolved in a solvent like DMSO, the stock solution should be aliquoted and stored at -80°C to minimize freeze-thaw cycles.

Troubleshooting Experimental Results

This section addresses common issues that may arise during experiments with **PF-06733804**.

Problem 1: No or lower than expected inhibitory effect in a cell-based assay.

Possible Causes and Solutions:

Cause	Recommended Action
Incorrect Inhibitor Concentration	Perform a dose-response experiment to determine the optimal IC50 for your specific cell line. A broad concentration range (e.g., 0.1 nM to 10 μ M) is recommended for initial experiments.
Low Trk Receptor Expression	Verify the expression levels of TrkA, TrkB, and TrkC in your cell line using techniques like Western blot or qPCR. Choose a cell line with known high expression of the target receptor for your experiments.
Cell Seeding Density	Optimize the cell seeding density to ensure cells are in the exponential growth phase during the experiment. Over-confluent or sparse cultures can lead to variable results.
Inadequate Incubation Time	The inhibitory effect of PF-06733804 may be time-dependent. Perform a time-course experiment (e.g., 24, 48, 72 hours) to determine the optimal incubation period for your assay.
Inhibitor Inactivity	Ensure the inhibitor has been stored correctly and has not undergone multiple freeze-thaw cycles. If in doubt, use a fresh aliquot or a new vial of the compound.
Assay Controls	Always include a vehicle control (e.g., DMSO) to account for solvent effects and a positive control (another known Trk inhibitor) to confirm assay performance.

Problem 2: High background or inconsistent results in an assay.

Possible Causes and Solutions:

Cause	Recommended Action
Cell Culture Contamination	Regularly test your cell lines for mycoplasma contamination. Ensure aseptic techniques are followed during all cell culture procedures.
Edge Effects in Multi-well Plates	To minimize evaporation and temperature gradients, avoid using the outer wells of the plate. Fill the perimeter wells with sterile PBS or media.
Uneven Cell Seeding	Ensure a single-cell suspension before seeding to avoid clumps. Pipette gently and use a consistent technique for all wells.
Reagent and Compound Pipetting Errors	Use calibrated pipettes and ensure proper mixing of reagents and the inhibitor in the media.
Inhibitor Precipitation	Visually inspect the media for any signs of precipitation after adding PF-06733804. If precipitation occurs, consider using a lower final concentration or a different solvent system (ensuring the final solvent concentration is non-toxic to cells).

Problem 3: Observing off-target effects or cellular toxicity.

Possible Causes and Solutions:

Cause	Recommended Action
High Inhibitor Concentration	High concentrations of kinase inhibitors can lead to off-target effects. Use the lowest effective concentration determined from your dose-response experiments.
Solvent Toxicity	Ensure the final concentration of the solvent (e.g., DMSO) in the cell culture medium is low (typically $\leq 0.1\%$) to avoid solvent-induced toxicity.
Cell Line Sensitivity	Some cell lines may be more sensitive to the inhibitor or the solvent. Perform a toxicity assay to determine the non-toxic concentration range for your specific cell line.
Confirmation of On-Target Effect	To confirm that the observed phenotype is due to Trk inhibition, consider performing rescue experiments by overexpressing a resistant Trk mutant or using a structurally different Trk inhibitor to see if it phenocopies the results.

Experimental Protocols

Cell Viability Assay (e.g., using CellTiter-Glo®)

This protocol provides a general framework for assessing the effect of **PF-06733804** on cell viability.

- Cell Seeding:
 - Harvest and count cells, then resuspend them in the appropriate growth medium.
 - Seed cells in a 96-well plate at a pre-determined optimal density.
 - Incubate the plate for 18-24 hours at 37°C and 5% CO₂ to allow for cell attachment.
- Compound Preparation and Treatment:

- Prepare a stock solution of **PF-06733804** in DMSO (e.g., 10 mM).
- Perform serial dilutions of the stock solution in complete growth medium to achieve the desired final concentrations. A typical dose-response curve might include concentrations from 0.1 nM to 10 μM.
- Add the diluted compound or vehicle control (DMSO) to the respective wells. Ensure the final DMSO concentration is consistent across all wells and does not exceed 0.1%.
- Incubation:
 - Incubate the plate for the desired time period (e.g., 72 hours) at 37°C and 5% CO₂.
- Viability Measurement:
 - Equilibrate the plate to room temperature for approximately 30 minutes.
 - Prepare and add the CellTiter-Glo® reagent to each well according to the manufacturer's protocol.
 - Mix the contents on an orbital shaker for 2 minutes to induce cell lysis.
 - Incubate at room temperature for 10 minutes to stabilize the luminescent signal.
 - Measure luminescence using a plate reader.
- Data Analysis:
 - Normalize the data to the vehicle-treated control wells and plot the results to determine the IC₅₀ value.

Western Blot for Phospho-Trk Inhibition

This protocol can be used to confirm the inhibition of Trk receptor phosphorylation by **PF-06733804**.

- Cell Treatment and Lysis:
 - Seed cells in a 6-well plate and grow to 70-80% confluency.

- Treat the cells with varying concentrations of **PF-06733804** or vehicle control for a predetermined time (e.g., 1-2 hours).
- Wash the cells with ice-cold PBS.
- Lyse the cells in RIPA buffer containing protease and phosphatase inhibitors.
- Quantify the protein concentration of the lysates using a BCA assay.
- SDS-PAGE and Western Blotting:
 - Normalize protein amounts and load equal amounts of protein per lane onto an SDS-PAGE gel.
 - Transfer the proteins to a PVDF membrane.
 - Block the membrane with 5% BSA or non-fat milk in TBST for 1 hour at room temperature.
 - Incubate the membrane with a primary antibody against phospho-TrkA/B/C overnight at 4°C.
 - Wash the membrane with TBST and incubate with an HRP-conjugated secondary antibody for 1 hour at room temperature.
 - Develop the blot using an ECL substrate and visualize the bands.
- Stripping and Re-probing:
 - To confirm equal protein loading, the membrane can be stripped and re-probed with an antibody against total Trk or a loading control like β -actin or GAPDH.

Visualizations

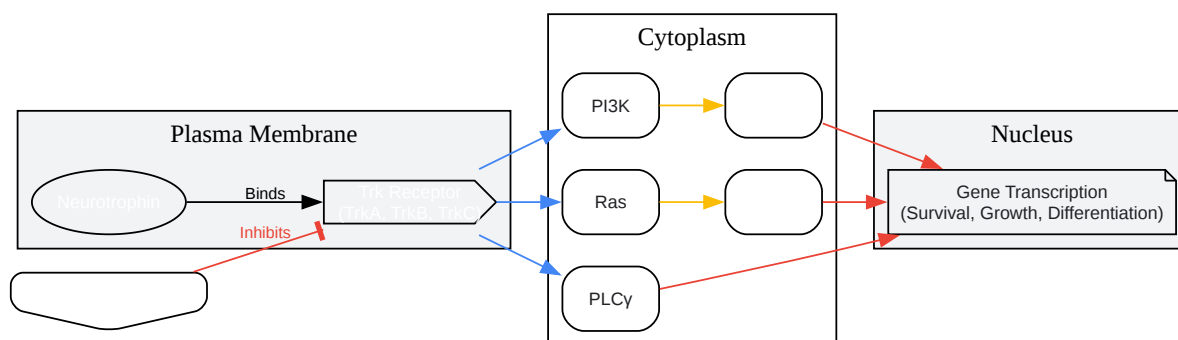

[Click to download full resolution via product page](#)

Caption: Trk signaling pathway and the inhibitory action of **PF-06733804**.

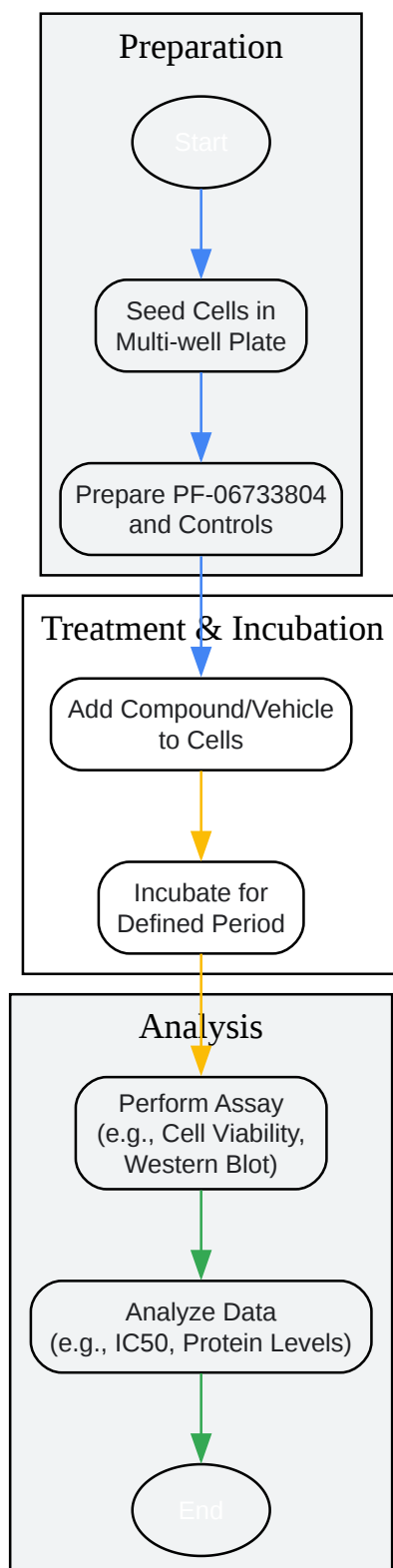

[Click to download full resolution via product page](#)

Caption: General experimental workflow for in vitro studies with **PF-06733804**.

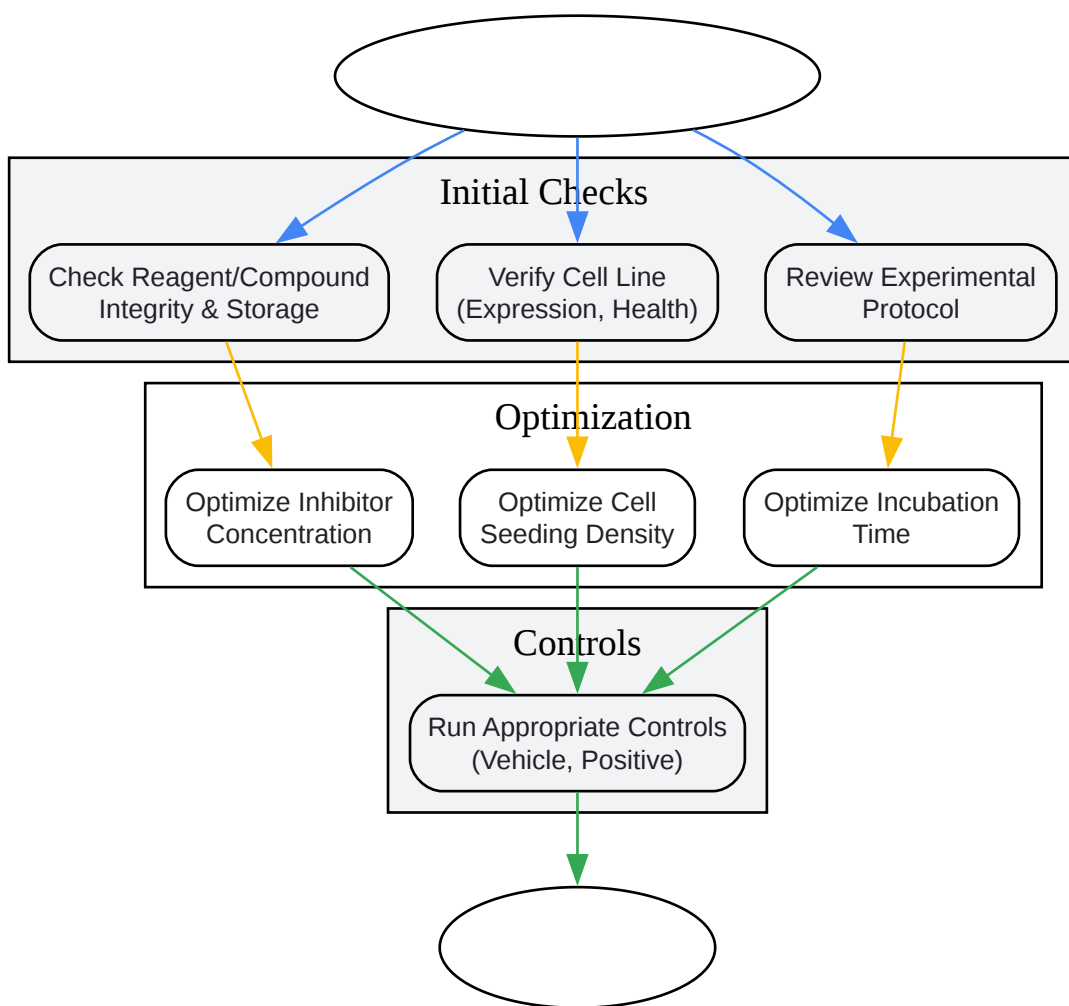

[Click to download full resolution via product page](#)

Caption: Logical troubleshooting workflow for unexpected experimental results.

- To cite this document: BenchChem. [Technical Support Center: PF-06733804 Experimental Troubleshooting]. BenchChem, [2026]. [Online PDF]. Available at: [\[https://www.benchchem.com/product/b15617577/docs#technical-support-center-pf-06733804-experimental-troubleshooting\]](https://www.benchchem.com/product/b15617577/docs#technical-support-center-pf-06733804-experimental-troubleshooting)

Disclaimer & Data Validity:

The information provided in this document is for Research Use Only (RUO) and is strictly not intended for diagnostic or therapeutic procedures. While BenchChem strives to provide accurate protocols, we make no warranties, express or implied, regarding the fitness of this product for every specific experimental setup.

Technical Support: The protocols provided are for reference purposes. Unsure if this reagent suits your experiment?

Need Industrial/Bulk Grade? [Request Custom Synthesis Quote](#)

BenchChem

Our mission is to be the trusted global source of essential and advanced chemicals, empowering scientists and researchers to drive progress in science and industry.

Contact

Address: 3281 E Guasti Rd
Ontario, CA 91761, United States
Phone: (601) 213-4426
Email: info@benchchem.com

[Contact our Ph.D. Support Team for a compatibility check](#)