

# Sigma Receptor Modulation by RC-106: A Technical Guide

**Author:** BenchChem Technical Support Team. **Date:** April 2026

## Compound of Interest

Compound Name: RC-106  
Cat. No.: B15617674

[Get Quote](#)

For Researchers, Scientists, and Drug Development Professionals

## Abstract

**RC-106**, identified as (E)-4-benzyl-1-[3-(naphthalen-2-yl)but-2-en-1-yl]piperidine, is a novel pan-sigma receptor (SR) modulator demonstrating significant potential as an anticancer agent. [1] This technical guide provides a comprehensive overview of the current understanding of **RC-106**'s interaction with sigma-1 (S1R) and sigma-2 (S2R/TMEM97) receptors. It details the compound's effects on intracellular signaling, particularly the induction of the terminal Unfolded Protein Response (UPR), and presents available data on its biological activity. This document also outlines the key experimental protocols utilized in the characterization of **RC-106** and visualizes the proposed signaling pathways and experimental workflows.

## Introduction to Sigma Receptors and RC-106

Sigma receptors are a unique class of intracellular proteins primarily located at the endoplasmic reticulum (ER) membrane, particularly at the mitochondria-associated membranes (MAM).[2] They are implicated in a variety of cellular functions and are considered therapeutic targets for a range of pathologies, including cancer.[2][3] **RC-106** has emerged as a significant

modulator of both S1R and S2R, exhibiting a distinct functional profile that leads to cytotoxic effects in cancer cells.[1][4]

## Quantitative Data on RC-106 Activity

While specific binding affinities ( $K_i$ ) for **RC-106** at sigma-1 and sigma-2 receptors are not yet publicly available in the reviewed literature, its functional activity and cytotoxic effects have been characterized. The available quantitative data are summarized in the table below.

| Parameter                    | Cell Line(s)             | Value(s)  | Reference(s) |
|------------------------------|--------------------------|---|--------------|
| Functional Profile           | -                        | S1R Antagonist, S2R Agonist                                       | [4]          |
| Proteasome Inhibition (IC50) | -                        | 35 $\mu$ M  | [5]          |
| Cytotoxicity (IC50)          | Panc-1, Capan-1, Capan-2 | 33 - 57 $\mu$ M (at 24, 48, 72h)                                  | [4]          |
| Antiproliferative Activity   | U87-MG (Glioblastoma)    | ~66% viability at 60 $\mu$ M                                      | [5]          |
| ROS Production               | Panc-1, Capan-1          | Significant increase at 50 $\mu$ M (6, 12, 24h)                   | [3]          |
| Cell Migration Inhibition    | Capan-1                  | Significant reduction at 20 $\mu$ M (48h) and 40-60 $\mu$ M (24h) | [4]          |

## Experimental Protocols

This section details the methodologies for key experiments cited in the study of **RC-106**.

### Sigma Receptor Binding Assays (General Protocol)

Competitive binding assays are employed to determine the affinity of a test compound for sigma receptors.

- Materials:

- Membrane preparations from tissues or cells expressing sigma receptors (e.g., guinea pig brain for S1R, rat liver for S2R).
- Radioligand: Typically --INVALID-LINK---pentazocine for S1R and [<sup>3</sup>H]-DTG for S2R.
- Unlabeled competing ligand (e.g., haloperidol) for non-specific binding determination.
- Test compound (**RC-106**) at various concentrations.
- Incubation buffer (e.g., 50 mM Tris-HCl, pH 7.4).
- Glass fiber filters.
- Scintillation cocktail and counter.
- Procedure:
  - Incubate membrane homogenates with the radioligand and varying concentrations of the test compound.
  - In a parallel set of tubes, incubate membranes with the radioligand and a high concentration of an unlabeled ligand to determine non-specific binding.
  - After incubation (e.g., 120 minutes at 25°C), terminate the reaction by rapid filtration through glass fiber filters.
  - Wash the filters rapidly with ice-cold buffer to remove unbound radioligand.
  - Measure the radioactivity retained on the filters using a liquid scintillation counter.
  - Calculate the specific binding at each concentration of the test compound.
  - Determine the IC<sub>50</sub> value (concentration of the test compound that inhibits 50% of the specific radioligand binding) by non-linear regression analysis.
  - Calculate the K<sub>i</sub> value using the Cheng-Prusoff equation:  $K_i = IC_{50} / (1 + [L]/K_d)$ , where [L] is the concentration of the radioligand and K<sub>d</sub> is its dissociation constant.

## Unfolded Protein Response (UPR) Activation Analysis

The effect of **RC-106** on the UPR is typically assessed by measuring the expression of key UPR markers.

- 3.2.1. Real-Time Quantitative PCR (qRT-PCR) for mRNA Expression:
  - Treat pancreatic cancer cell lines (e.g., Panc-1, Capan-1) with **RC-106** (e.g., 50  $\mu$ M) for various time points (e.g., 6, 12, 24 hours).
  - Extract total RNA from the cells using a suitable kit.
  - Synthesize cDNA from the RNA templates using reverse transcriptase.
  - Perform qRT-PCR using specific primers for UPR target genes such as GRP78 (BiP), ATF4, and CHOP.
  - Normalize the expression levels to a housekeeping gene (e.g., GAPDH).
  - Calculate the fold change in mRNA expression compared to untreated control cells.
- 3.2.2. Western Blot for Protein Expression:
  - Lyse the **RC-106**-treated and control cells to extract total protein.
  - Determine protein concentration using a standard assay (e.g., BCA assay).
  - Separate the proteins by SDS-PAGE and transfer them to a PVDF membrane.
  - Block the membrane to prevent non-specific antibody binding.
  - Incubate the membrane with primary antibodies against GRP78, ATF4, CHOP, and a loading control (e.g.,  $\beta$ -actin).
  - Wash the membrane and incubate with a corresponding secondary antibody conjugated to an enzyme (e.g., HRP).
  - Detect the protein bands using a chemiluminescent substrate and image the blot.

- Quantify the band intensities and normalize to the loading control.
- 3.2.3. Immunofluorescence for Protein Localization:
  - Grow cells on coverslips and treat with **RC-106**.
  - Fix the cells with paraformaldehyde and permeabilize with a detergent (e.g., Triton X-100).
  - Block non-specific binding sites.
  - Incubate with primary antibodies against UPR markers.
  - Wash and incubate with fluorescently labeled secondary antibodies.
  - Mount the coverslips on slides with a mounting medium containing a nuclear stain (e.g., DAPI).
  - Visualize the protein localization using a fluorescence or confocal microscope.

## Cell Viability and Apoptosis Assays

- MTS Assay for Cell Viability:
  - Seed cells in a 96-well plate and treat with a range of **RC-106** concentrations.
  - After the desired incubation period, add the MTS reagent to each well.
  - Incubate for a few hours to allow for the conversion of the tetrazolium salt to formazan by viable cells.
  - Measure the absorbance at 490 nm using a microplate reader.
  - Calculate the percentage of cell viability relative to untreated controls.
- Flow Cytometry for Apoptosis:
  - Treat cells with **RC-106**.

- Harvest the cells and stain with Annexin V (to detect early apoptosis) and Propidium Iodide (PI) (to detect late apoptosis/necrosis).
- Analyze the stained cells using a flow cytometer to quantify the percentage of apoptotic and necrotic cells.

## Signaling Pathways and Experimental Workflows

The following diagrams, generated using the DOT language for Graphviz, illustrate the key signaling pathways and experimental workflows associated with **RC-106**'s mechanism of action.

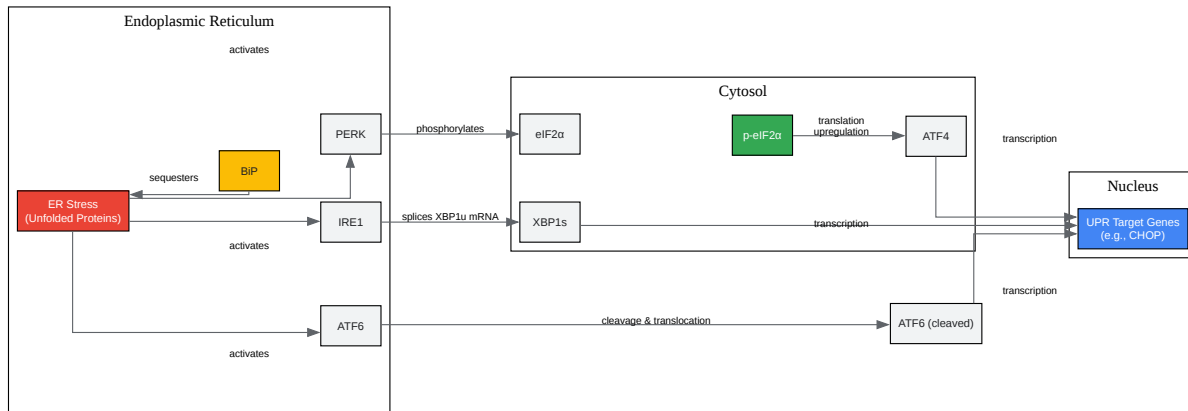

[Click to download full resolution via product page](#)

Caption: General Unfolded Protein Response (UPR) Signaling Pathway.

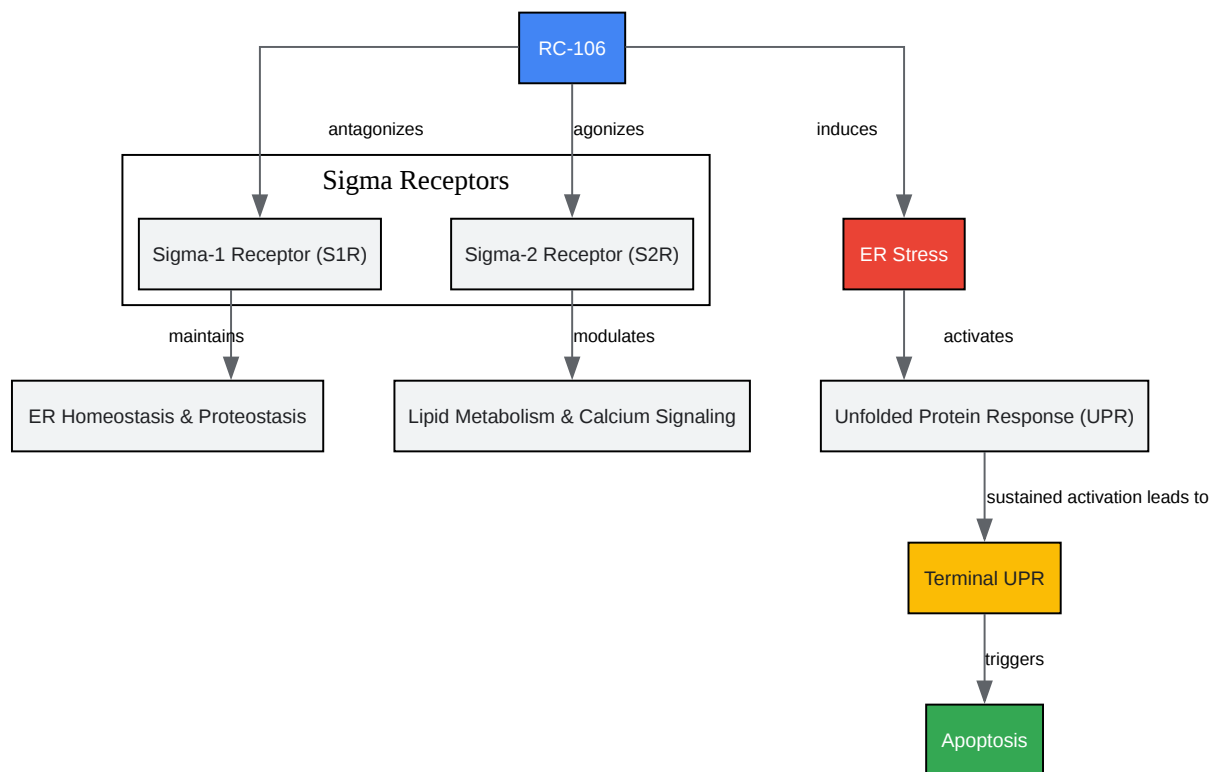

[Click to download full resolution via product page](#)

Caption: Proposed Mechanism of Action for **RC-106**.

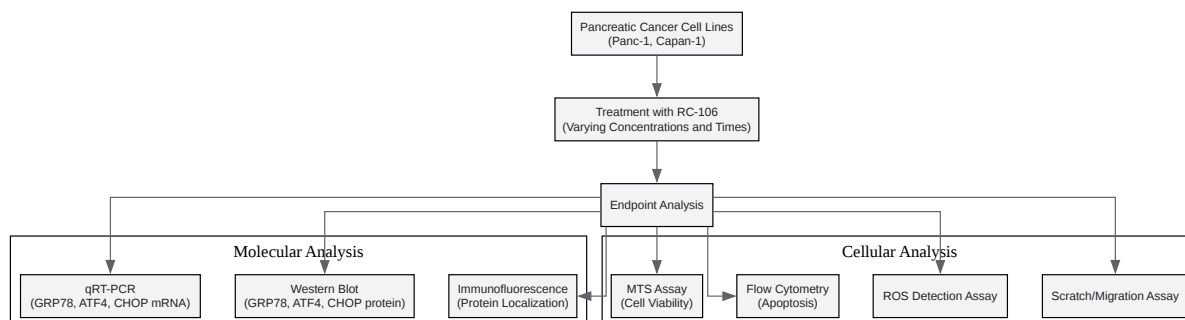

[Click to download full resolution via product page](#)

Caption: General Experimental Workflow for **RC-106** Characterization.

## Conclusion

**RC-106** is a promising pan-sigma receptor modulator with a clear cytotoxic effect on pancreatic cancer cells, mediated through the induction of the terminal Unfolded Protein Response. Its dual activity as a sigma-1 receptor antagonist and a sigma-2 receptor agonist presents a novel mechanism for anticancer therapy. Further research is warranted to elucidate the precise binding kinetics of **RC-106** and to fully explore its therapeutic potential in preclinical and clinical settings. The detailed experimental protocols and pathway diagrams provided in this guide serve as a valuable resource for researchers in the field of sigma receptor pharmacology and cancer drug development.

### Need Custom Synthesis?

BenchChem offers custom synthesis for rare earth carbides and specific isotopic labeling.

Email: [info@benchchem.com](mailto:info@benchchem.com) or [Request Quote Online](#).

## References

- [1. Exploring the RC-106 Chemical Space: Design and Synthesis of Novel \(E\)-1-\(3-Arylbut-2-en-1-yl\)-4-\(Substituted\) Piperazine Derivatives as Potential Anticancer Agents - PMC \[pmc.ncbi.nlm.nih.gov\]](#)
- [2. Frontiers | PB28, the Sigma-1 and Sigma-2 Receptors Modulator With Potent Anti-SARS-CoV-2 Activity: A Review About Its Pharmacological Properties and Structure Affinity Relationships \[frontiersin.org\]](#)
- [3. Pan-Sigma Receptor Modulator RC-106 Induces Terminal Unfolded Protein Response In In Vitro Pancreatic Cancer Model - PMC \[pmc.ncbi.nlm.nih.gov\]](#)
- [4. Anti-tumor Efficacy Assessment of the Sigma Receptor Pan Modulator RC-106. A Promising Therapeutic Tool for Pancreatic Cancer - PMC \[pmc.ncbi.nlm.nih.gov\]](#)
- [5. medchemexpress.com \[medchemexpress.com\]](#)
- To cite this document: BenchChem. [Sigma Receptor Modulation by RC-106: A Technical Guide]. BenchChem, [2026]. [Online PDF]. Available at: [\[https://www.benchchem.com/product/b15617674/docs#sigma-receptor-modulation-by-rc-106-a-technical-guide\]](https://www.benchchem.com/product/b15617674/docs#sigma-receptor-modulation-by-rc-106-a-technical-guide)

---

### Disclaimer & Data Validity:

The information provided in this document is for Research Use Only (RUO) and is strictly not intended for diagnostic or therapeutic procedures. While BenchChem strives to provide accurate protocols, we make no warranties, express or implied, regarding the fitness of this product for every specific experimental setup.

**Technical Support:** The protocols provided are for reference purposes. Unsure if this reagent suits your experiment?

**Need Industrial/Bulk Grade?** [Request Custom Synthesis Quote](#)

# BenchChem

Our mission is to be the trusted global source of essential and advanced chemicals, empowering scientists and researchers to drive progress in science and industry.

## Contact

Address: 3281 E Guasti Rd

Ontario, CA 91761, United States

Phone: (601) 213-4426

Email: [info@benchchem.com](mailto:info@benchchem.com)

[Contact our Ph.D. Support Team for a compatibility check](#)