

Independent Verification of PF-06733804's Mechanism: A Comparative Guide

Author: BenchChem Technical Support Team. **Date:** April 2026

Compound of Interest

Compound Name: PF-06733804

CAS No.: 1873373-33-1

Cat. No.: B15617577

[Get Quote](#)

For Researchers, Scientists, and Drug Development Professionals

This guide provides an objective comparison of the pan-Tropomyosin receptor kinase (Trk) inhibitor, **PF-06733804**, with alternative Trk inhibitors. The information presented is based on available preclinical data to assist researchers in evaluating its mechanism of action and performance.

Executive Summary

PF-06733804 is a potent pan-Trk inhibitor, targeting TrkA, TrkB, and TrkC kinases. These kinases are critical components of the neurotrophin signaling pathway, which plays a significant role in neuronal survival, differentiation, and synaptic plasticity. Dysregulation of this pathway due to NTRK gene fusions is an oncogenic driver in a variety of cancers. This guide details the mechanism of action of **PF-06733804**, compares its in vitro potency with other notable Trk inhibitors, and provides standardized experimental protocols for independent verification.

Mechanism of Action: Trk Inhibition

PF-06733804 functions as an ATP-competitive inhibitor of Trk kinases. By binding to the ATP-binding pocket of the Trk receptor's kinase domain, it blocks the autophosphorylation and subsequent activation of the receptor. This inhibition effectively halts the downstream signaling cascades, primarily the RAS/RAF/MEK/ERK, PI3K/AKT/mTOR, and PLC γ pathways, which are crucial for cancer cell proliferation, survival, and growth.

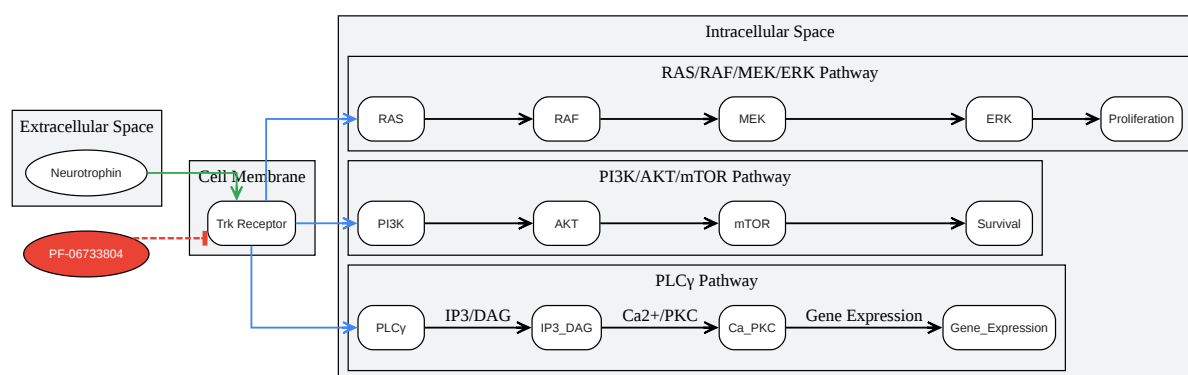

[Click to download full resolution via product page](#)

Caption: Trk signaling pathway and the inhibitory action of **PF-06733804**.

Comparative Performance: In Vitro Potency

The following table summarizes the half-maximal inhibitory concentration (IC₅₀) values of **PF-06733804** against Trk kinases in cell-based assays, alongside data for the first-generation Trk inhibitors, larotrectinib and entrectinib. It is important to note that these values are compiled from different studies and direct comparisons should be made with caution due to potential variations in experimental conditions.

Compound	TrkA IC50 (nM)	TrkB IC50 (nM)	TrkC IC50 (nM)
PF-06733804	8.4[1][2]	6.2[1][2]	2.2[1][2]
Larotrectinib	5 - 11	5 - 11	5 - 11
Entrectinib	1 - 5	1 - 5	1 - 5

Experimental Protocols for Independent Verification

To independently verify the mechanism of action of **PF-06733804**, the following key experiments are recommended.

Western Blot for Trk Pathway Phosphorylation

This experiment aims to demonstrate the inhibition of Trk autophosphorylation and downstream signaling.

Methodology:

- **Cell Culture and Treatment:** Culture a suitable cell line expressing Trk receptors (e.g., a cell line with a known NTRK fusion). Seed cells and allow them to adhere overnight. Treat cells with varying concentrations of **PF-06733804** for a specified duration (e.g., 2 hours). Include a vehicle-only control.
- **Cell Lysis:** Wash cells with ice-cold phosphate-buffered saline (PBS) and lyse them using RIPA buffer supplemented with protease and phosphatase inhibitors.
- **Protein Quantification:** Determine the protein concentration of each lysate using a BCA or similar protein assay.
- **SDS-PAGE and Western Blotting:** Separate equal amounts of protein from each sample by SDS-polyacrylamide gel electrophoresis and transfer the proteins to a PVDF or nitrocellulose membrane.
- **Immunoblotting:** Block the membrane with 5% non-fat milk or bovine serum albumin (BSA) in Tris-buffered saline with Tween 20 (TBST). Incubate the membrane with primary antibodies

specific for phosphorylated Trk (p-Trk), total Trk, phosphorylated AKT (p-AKT), total AKT, phosphorylated ERK (p-ERK), and total ERK overnight at 4°C.

- Detection: Wash the membrane and incubate with appropriate HRP-conjugated secondary antibodies. Detect the chemiluminescent signal using an imaging system.
- Analysis: Quantify the band intensities and normalize the levels of phosphorylated proteins to the corresponding total protein levels.

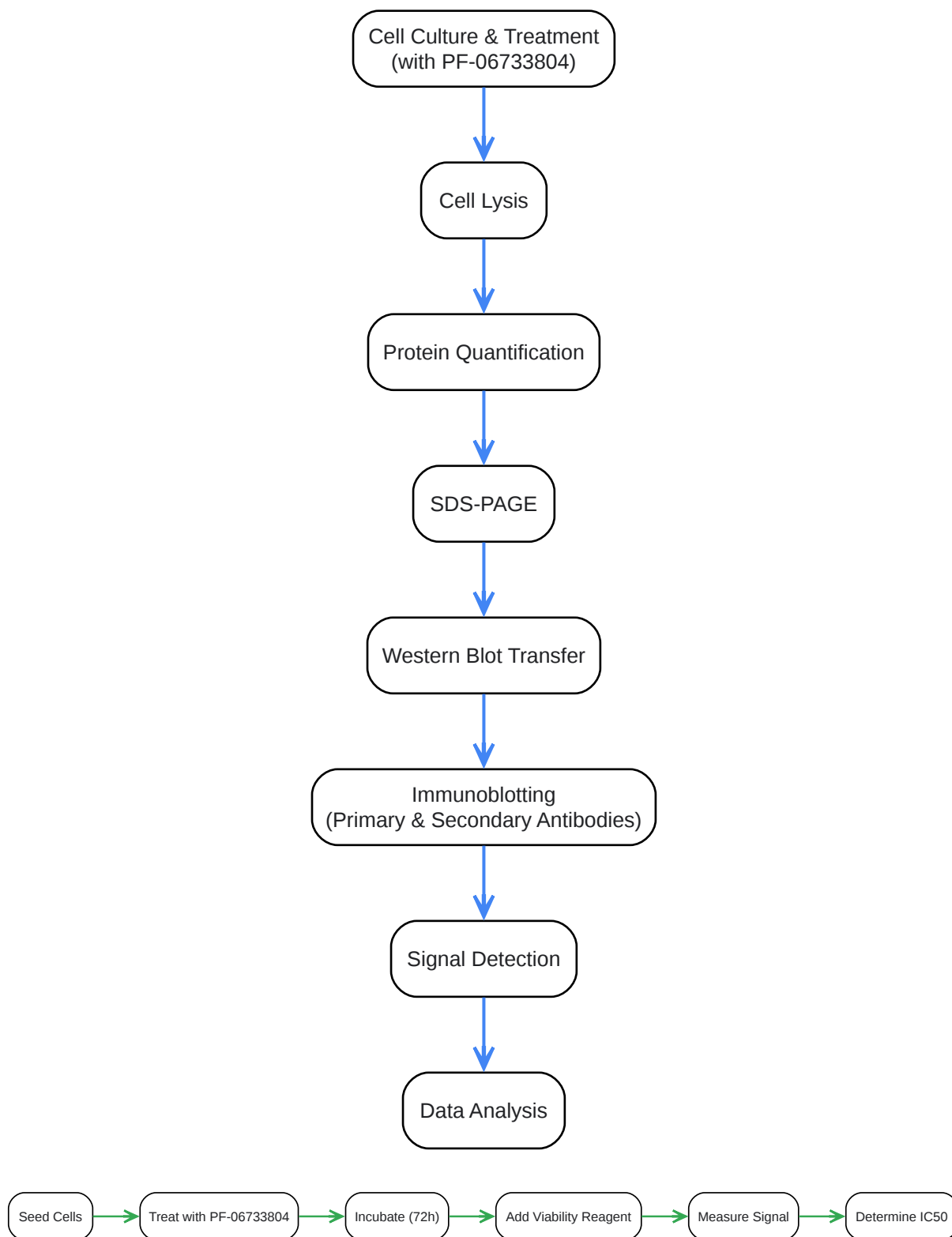

[Click to download full resolution via product page](#)

Need Custom Synthesis?

BenchChem offers custom synthesis for rare earth carbides and specific isotopic labeling.

Email: info@benchchem.com or [Request Quote Online](#).

References

- [1. medchemexpress.com \[medchemexpress.com\]](https://www.medchemexpress.com)
- [2. PF-06733804 - Immunomart \[immunomart.com\]](https://www.immunomart.com)
- To cite this document: BenchChem. [Independent Verification of PF-06733804's Mechanism: A Comparative Guide]. BenchChem, [2026]. [Online PDF]. Available at: [\[https://www.benchchem.com/product/b15617577/docs#independent-verification-of-pf-06733804-s-mechanism-a-comparative-guide\]](https://www.benchchem.com/product/b15617577/docs#independent-verification-of-pf-06733804-s-mechanism-a-comparative-guide)

Disclaimer & Data Validity:

The information provided in this document is for Research Use Only (RUO) and is strictly not intended for diagnostic or therapeutic procedures. While BenchChem strives to provide accurate protocols, we make no warranties, express or implied, regarding the fitness of this product for every specific experimental setup.

Technical Support: The protocols provided are for reference purposes. Unsure if this reagent suits your experiment?

Need Industrial/Bulk Grade? [Request Custom Synthesis Quote](#)

BenchChem

Our mission is to be the trusted global source of essential and advanced chemicals, empowering scientists and researchers to drive progress in science and industry.

Contact

Address: 3281 E Guasti Rd

Ontario, CA 91761, United States

Phone: (601) 213-4426

Email: info@benchchem.com

Contact our Ph.D. Support Team for a compatibility check