

An In-depth Technical Guide on the Selectivity Profile of TAE226

Author: BenchChem Technical Support Team. **Date:** April 2026

Compound of Interest

Compound Name: T-226296
Cat. No.: B15617282

[Get Quote](#)

Disclaimer: Initial searches for the compound "**T-226296**" did not yield any publicly available information. It is presumed that this may be an internal designation or a typographical error. This guide therefore focuses on the well-characterized and structurally related dual Focal Adhesion Kinase (FAK) and Insulin-like Growth Factor-1 Receptor (IGF-1R) inhibitor, TAE226, to provide a representative example of the requested technical content.

This document is intended for researchers, scientists, and drug development professionals, providing a detailed overview of the kinase selectivity profile, experimental methodologies, and relevant signaling pathways for the small molecule inhibitor TAE226 (also known as NVP-TAE226).

Executive Summary

TAE226 is a potent, ATP-competitive, small-molecule inhibitor targeting Focal Adhesion Kinase (FAK).[1] It also demonstrates significant inhibitory activity against the Insulin-like Growth Factor-1 Receptor (IGF-1R), classifying it as a dual FAK/IGF-1R inhibitor.[2] FAK is a non-receptor tyrosine kinase that plays a crucial role in cell adhesion, migration, proliferation, and survival.[3] IGF-1R is a transmembrane receptor tyrosine kinase involved in cell growth and

metabolism.[4] The dual inhibition of these pathways gives TAE226 a broad spectrum of anti-proliferative and anti-tumor activity across various cancer types.[4][5]

Kinase Selectivity Profile

TAE226 exhibits high potency against FAK. Its selectivity has been profiled against other related kinases, showing a less potent but significant activity against several other important targets.

Table 2.1: In Vitro Kinase Inhibitory Profile of TAE226

Target Kinase	IC50 (nM)	Selectivity Notes
FAK	5.5	Primary target.
Pyk2	3.5	Potent inhibition, comparable to FAK.
IGF-1R	~55 - 550	Approximately 10- to 100-fold less potent than against FAK. [1]
InsR	~55 - 550	Approximately 10- to 100-fold less potent than against FAK. [1]
ALK	~55 - 550	Approximately 10- to 100-fold less potent than against FAK. [1]
c-Met	~55 - 550	Approximately 10- to 100-fold less potent than against FAK. [1]

Note: IC50 values represent the concentration of an inhibitor that is required for 50% inhibition of the target enzyme's activity in vitro. Exact IC50 values for secondary targets are approximated based on descriptive data.

Cellular Activity Profile

TAE226 has demonstrated broad anti-proliferative activity against a diverse panel of human cancer cell lines. The mean GI50 value across a panel of 37 cancer cell lines was 0.76 $\mu\text{mol/L}$, with a range of 0.14 to 3.6 μM .^{[4][5]}

Table 3.1: Anti-proliferative Activity of TAE226 in Selected Human Cancer Cell Lines

Cell Line	Cancer Type	GI50 (μM)
HCT116	Colon Cancer	0.4
U87MG	Glioblastoma	1.2
MIA PaCa-2	Pancreatic Cancer	
4T1	Murine Breast Cancer	
MCF-7	Breast Cancer	
MCF-7/ADR-RES	Breast Cancer (MDR)	

Note: Specific GI50 values for all cell lines in the panel are detailed in the source literature.^[4] TAE226 was shown to be effective against both taxane-sensitive and taxane-resistant ovarian carcinoma cell lines and was not a substrate for P-glycoprotein in MCF-7/ADR-RES cells.^[4]

Experimental Protocols

In Vitro Kinase Inhibition Assay (General Protocol)

While the specific protocol for TAE226's initial screening is proprietary, a general method for determining kinase IC50 values involves a radiometric or fluorescence-based assay.

- Reagents: Recombinant human kinase, appropriate peptide substrate, ATP (often radiolabeled with ^{32}P or ^{33}P), kinase buffer, and test compound (TAE226).
- Procedure:
 - The kinase is incubated with varying concentrations of the inhibitor (e.g., TAE226) in the kinase reaction buffer.

- The kinase reaction is initiated by adding the substrate and ATP.
- The reaction is allowed to proceed for a specified time at a controlled temperature (e.g., 30°C).
- The reaction is stopped, typically by adding a solution like phosphoric acid.
- The phosphorylated substrate is separated from the remaining radiolabeled ATP, often by spotting the mixture onto a filter membrane which binds the peptide substrate.
- The amount of incorporated radioactivity on the filter is quantified using a scintillation counter.
- Data Analysis: The percentage of kinase activity relative to a vehicle control is plotted against the logarithm of the inhibitor concentration. The IC50 value is determined using non-linear regression analysis.

Cellular Proliferation (Sulforhodamine B - SRB) Assay

The anti-proliferative activity of TAE226 was determined using the Sulforhodamine B (SRB) assay, which measures cell density based on total cellular protein content.[4]

- Cell Plating: Cancer cells are seeded in 96-well microtiter plates at an optimal density to ensure exponential growth throughout the experiment and incubated for 24 hours to allow for attachment.[6][7]
- Compound Treatment: Cells are treated with serial dilutions of TAE226 or a vehicle control (e.g., DMSO) and incubated for a specified period (e.g., 48-72 hours).[1]
- Cell Fixation: The culture medium is removed, and cells are fixed by adding cold 10% (w/v) trichloroacetic acid (TCA) to each well, followed by incubation at 4°C for at least 1 hour.[6][8]
- Staining: The TCA is removed, and the plates are washed with water and air-dried. A 0.4% (w/v) SRB solution in 1% acetic acid is added to each well and incubated at room temperature for 30 minutes.[6][9]
- Washing: Unbound dye is removed by washing the plates multiple times with 1% (v/v) acetic acid.[6][8]

- **Solubilization and Readout:** The plates are air-dried completely. The protein-bound SRB dye is solubilized by adding a 10 mM Tris base solution (pH 10.5) to each well.[7][8] The optical density (absorbance) is measured on a microplate reader at approximately 510-540 nm.[7][9]
- **Data Analysis:** The GI50 value is calculated by plotting the percentage of cell growth against the drug concentration.

Western Blot Analysis of Protein Phosphorylation

To confirm the mechanism of action, the effect of TAE226 on the phosphorylation status of FAK and downstream effectors like Akt is assessed via Western blotting.[4]

- **Cell Lysis:** Cells treated with TAE226 are lysed in a buffer containing protease and phosphatase inhibitors to preserve the phosphorylation state of proteins.[10]
- **Protein Quantification:** The total protein concentration of the lysates is determined using a standard method like the BCA assay to ensure equal loading.[10]
- **SDS-PAGE and Transfer:** Equal amounts of protein from each sample are separated by size using sodium dodecyl sulfate-polyacrylamide gel electrophoresis (SDS-PAGE) and then transferred to a PVDF or nitrocellulose membrane.[10]
- **Blocking and Antibody Incubation:** The membrane is blocked (e.g., with 5% BSA in TBST) to prevent non-specific antibody binding. It is then incubated overnight at 4°C with primary antibodies specific for phosphorylated proteins (e.g., phospho-FAK Y397, phospho-Akt S473) and total proteins as loading controls.[4][11]
- **Secondary Antibody and Detection:** The membrane is washed and incubated with a horseradish peroxidase (HRP)-conjugated secondary antibody. The signal is detected using an enhanced chemiluminescence (ECL) substrate and captured with an imaging system.[10]

Signaling Pathway Visualizations

TAE226 exerts its effects by inhibiting the FAK and IGF-1R signaling pathways, which are critical for tumor growth, survival, and metastasis.

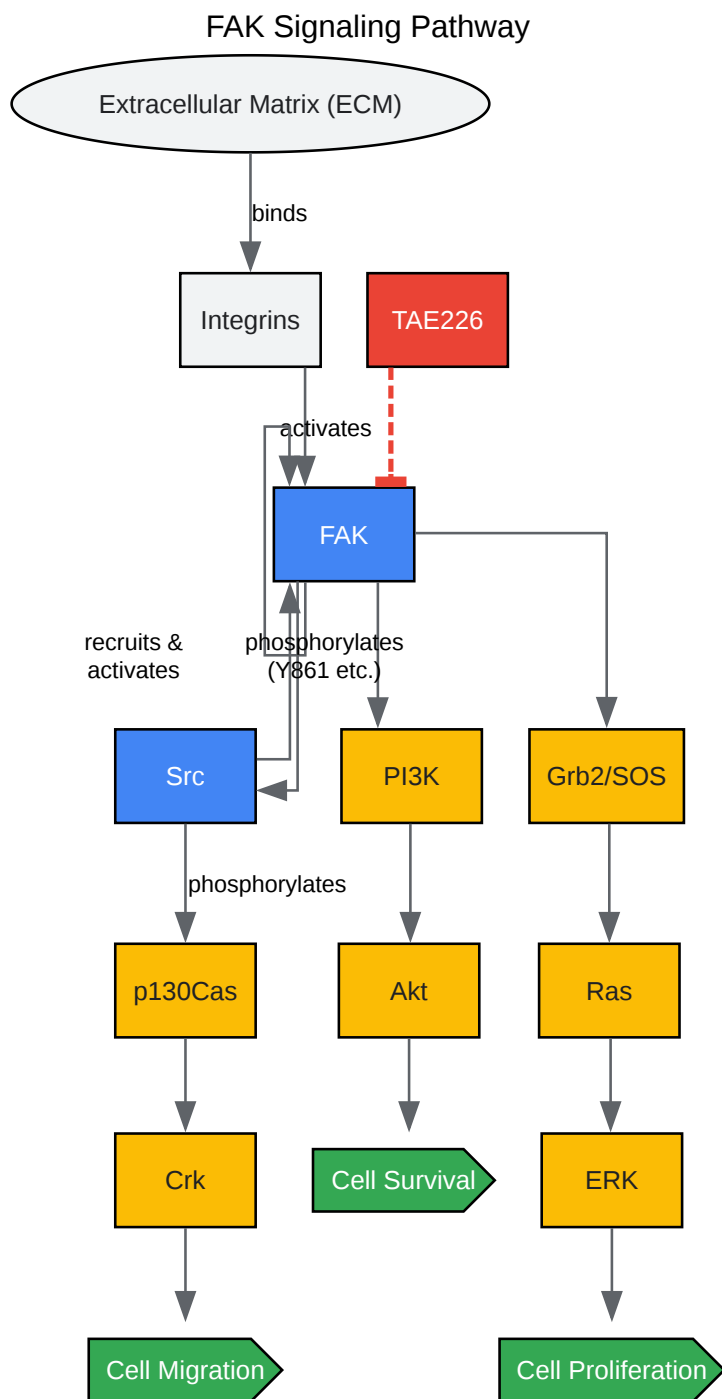

[Click to download full resolution via product page](#)

Caption: FAK signaling cascade initiated by integrin engagement with the ECM.

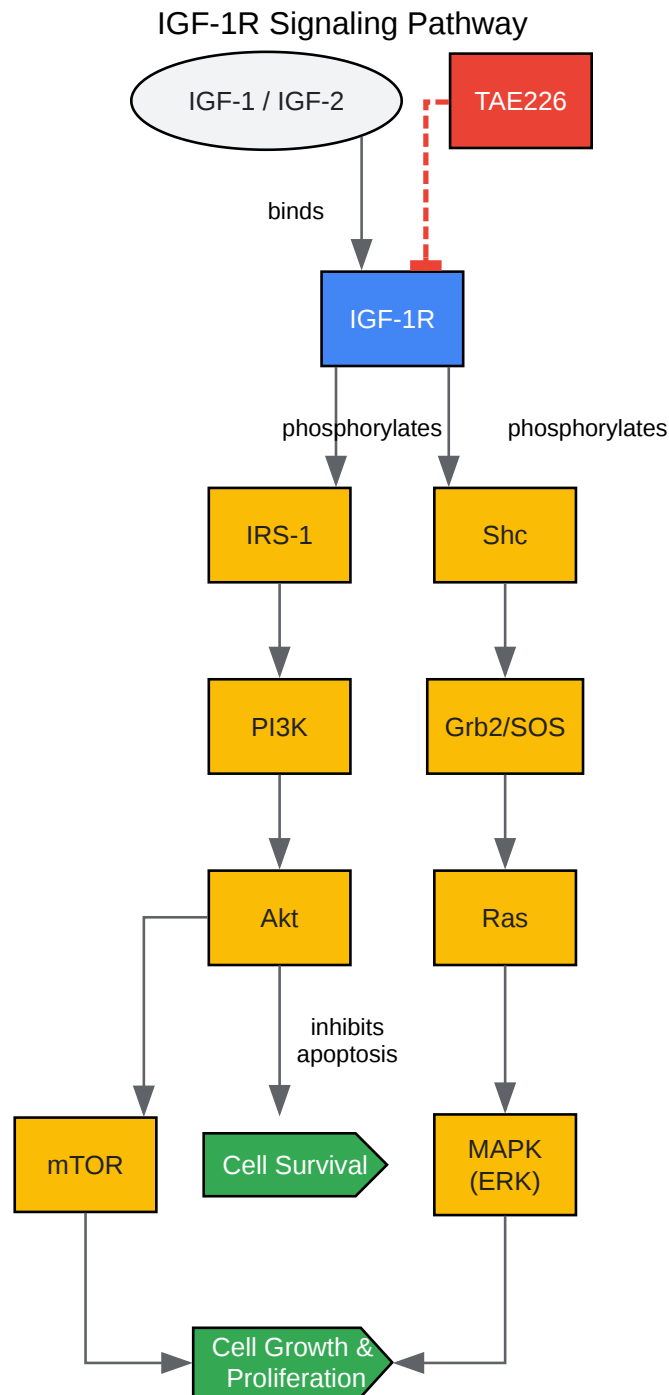

[Click to download full resolution via product page](#)

Caption: IGF-1R signaling through the PI3K/Akt and Ras/MAPK pathways.

Need Custom Synthesis?

BenchChem offers custom synthesis for rare earth carbides and specific isotopic labeling.

Email: info@benchchem.com or [Request Quote Online](#).

References

- [1. selleckchem.com \[selleckchem.com\]](https://www.selleckchem.com)
- [2. TAE226, a dual inhibitor of focal adhesion kinase and insulin-like growth factor-I receptor, is effective for Ewing sarcoma - PubMed \[pubmed.ncbi.nlm.nih.gov\]](#)
- [3. A small molecule focal adhesion kinase \(FAK\) inhibitor, targeting Y397 site: 1-\(2-hydroxyethyl\)-3,5,7-triaza-1-azoniatricyclo\[3.3.1.1^{3,7}\]decane; bromide effectively inhibits FAK autophosphorylation activity and decreases cancer cell viability, clonogenicity and tumor growth in vivo - PMC \[pmc.ncbi.nlm.nih.gov\]](#)
- [4. Pharmacological profiling of a dual FAK/IGF-1R kinase inhibitor TAE226 in cellular and in vivo tumor models - PMC \[pmc.ncbi.nlm.nih.gov\]](#)
- [5. Pharmacological profiling of a dual FAK/IGF-1R kinase inhibitor TAE226 in cellular and in vivo tumor models - PubMed \[pubmed.ncbi.nlm.nih.gov\]](#)
- [6. Sulforhodamine B \(SRB\) Assay Protocol - Creative Bioarray | Creative Bioarray \[creative-bioarray.com\]](#)
- [7. benchchem.com \[benchchem.com\]](https://www.benchchem.com)
- [8. SRB assay for measuring target cell killing \[protocols.io\]](https://www.protocols.io)
- [9. Sulforhodamine B Assay: A Sensitive Assay to Measure Drug Resistance Via Determination of Cellular Protein Content in Cancer Cells \[jove.com\]](#)
- [10. benchchem.com \[benchchem.com\]](https://www.benchchem.com)
- [11. ccrod.cancer.gov \[ccrod.cancer.gov\]](https://ccrod.cancer.gov)
- To cite this document: BenchChem. [An In-depth Technical Guide on the Selectivity Profile of TAE226]. BenchChem, [2026]. [Online PDF]. Available at: [\[https://www.benchchem.com/product/b15617282/docs#an-in-depth-technical-guide-on-the-selectivity-profile-of-tae226\]](https://www.benchchem.com/product/b15617282/docs#an-in-depth-technical-guide-on-the-selectivity-profile-of-tae226)

Disclaimer & Data Validity:

The information provided in this document is for Research Use Only (RUO) and is strictly not intended for diagnostic or therapeutic procedures. While BenchChem strives to provide accurate protocols, we make no warranties, express or implied, regarding the fitness of this product for every specific experimental setup.

Technical Support: The protocols provided are for reference purposes. Unsure if this reagent suits your experiment?

Need Industrial/Bulk Grade? [Request Custom Synthesis Quote](#)

BenchChem

Our mission is to be the trusted global source of essential and advanced chemicals, empowering scientists and researchers to drive progress in science and industry.

Contact

Address: 3281 E Guasti Rd
Ontario, CA 91761, United States
Phone: (601) 213-4426
Email: info@benchchem.com

[Contact our Ph.D. Support Team for a compatibility check](#)