

# Technical Support Center: Optimizing LY2365109 Concentration for Neuronal Cell Cultures

**Author:** BenchChem Technical Support Team. **Date:** April 2026

## Compound of Interest

Compound Name: LY2365109

Cat. No.: B15616539

[Get Quote](#)

This technical support center provides troubleshooting guides and frequently asked questions (FAQs) for researchers, scientists, and drug development professionals working with the GlyT1 inhibitor, **LY2365109**, in neuronal cell cultures.

## Frequently Asked Questions (FAQs)

Q1: What is the mechanism of action of **LY2365109**?

A1: **LY2365109** is a potent and selective inhibitor of the glycine transporter 1 (GlyT1).[1] GlyT1 is responsible for the reuptake of glycine from the synaptic cleft. By inhibiting GlyT1, **LY2365109** increases the extracellular concentration of glycine. Glycine is an essential co-agonist for the N-methyl-D-aspartate (NMDA) receptor. Therefore, elevated glycine levels potentiate NMDA receptor-mediated glutamatergic neurotransmission.

Q2: What is the recommended starting concentration for **LY2365109** in neuronal cell cultures?

A2: A specific optimal concentration for **LY2365109** in neuronal cell cultures has not been definitively established in the literature. However, based on its IC50 for GlyT1 (15.8 nM) and data from similar selective GlyT1 inhibitors, a starting concentration range of 10 nM to 1  $\mu$ M is

recommended for initial experiments. It is crucial to perform a dose-response study to determine the optimal concentration for your specific cell type and experimental endpoint.

Q3: How should I prepare a stock solution of **LY2365109**?

A3: **LY2365109** hydrochloride is soluble in DMSO (up to 100 mM) and ethanol (up to 50 mM). It is poorly soluble in aqueous solutions. It is recommended to prepare a concentrated stock solution in DMSO (e.g., 10 mM) and then dilute it to the final working concentration in your cell culture medium. To minimize the final DMSO concentration in your culture, it is advisable to make an intermediate dilution in culture medium before adding it to the cells.

Q4: What are the potential off-target effects or toxicity concerns with **LY2365109**?

A4: At higher concentrations, GlyT1 inhibitors, including **LY2365109**, can lead to excessive elevation of extracellular glycine.[2] This may result in the activation of strychnine-sensitive glycine receptors, which can be inhibitory and potentially lead to adverse effects.[2] In vivo studies have shown that high doses of **LY2365109** can impair motor performance and respiration.[2] Therefore, it is essential to carefully titrate the concentration to avoid potential neurotoxicity in vitro. An "inverted-U" dose-response curve, where higher doses lead to reduced or adverse effects, is a possibility.

## Troubleshooting Guide

Issue	Potential Cause	Suggested Solution
No observable effect on NMDA receptor function.	Suboptimal Concentration: The concentration of LY2365109 may be too low.	Perform a dose-response experiment with a wider concentration range (e.g., 1 nM to 10 $\mu$ M) to identify the optimal concentration.
Low Endogenous Glycine: The baseline glycine concentration in your culture medium may be too low for GlyT1 inhibition to have a significant effect.	Consider supplementing the culture medium with a low concentration of glycine (e.g., 1-10 $\mu$ M) to provide a substrate for GlyT1.	
Decreased neuronal viability or signs of cytotoxicity.	Concentration Too High: Excessive inhibition of GlyT1 can lead to excitotoxicity or other adverse effects.	Lower the concentration of LY2365109. Perform a cell viability assay (e.g., MTT, CellTiter-Glo) to determine the cytotoxic concentration (IC50) in your cell model.
Solvent Toxicity: The final concentration of the solvent (e.g., DMSO) in the culture medium may be too high.	Ensure the final DMSO concentration is below 0.1% (v/v). Prepare higher stock concentrations of LY2365109 to minimize the volume of solvent added.	
Inconsistent or variable results between experiments.	Stock Solution Degradation: Improper storage of the LY2365109 stock solution can lead to loss of activity.	Aliquot the stock solution into single-use vials and store at $-20^{\circ}\text{C}$ or $-80^{\circ}\text{C}$ . Avoid repeated freeze-thaw cycles.
Cell Culture Variability: Differences in cell density, passage number, or culture conditions can affect the response to LY2365109.	Standardize your cell culture protocols, including seeding density and media changes. Use cells within a consistent passage number range.	

## Data Presentation

Table 1: Properties of **LY2365109**

Property	Value	Reference
Target	Glycine Transporter 1 (GlyT1)	[1]
IC50 (for glycine uptake)	15.8 nM	
Solubility	DMSO ( $\geq 100$ mM), Ethanol ( $\geq 50$ mM)	

Table 2: Recommended Starting Concentrations for Optimization Studies

Parameter	Concentration Range	Notes
NMDA Receptor Potentiation	10 nM - 1 $\mu$ M	Based on IC50 and data from similar compounds. A dose-response study is essential.
Neurotoxicity Assessment	100 nM - 100 $\mu$ M	To determine the concentration at which LY2365109 becomes toxic to the neuronal culture.

## Experimental Protocols

### Protocol 1: Determining the Optimal Concentration of **LY2365109** using a Neuronal Viability Assay

- Cell Plating: Plate primary neurons or a neuronal cell line in a 96-well plate at a predetermined optimal density.
- Compound Preparation: Prepare a serial dilution of **LY2365109** in culture medium. The final concentrations should range from 10 nM to 100  $\mu$ M. Include a vehicle control (medium with the same final concentration of DMSO).

- Treatment: After allowing the cells to adhere and stabilize (typically 24-48 hours), replace the medium with the prepared **LY2365109** dilutions.
- Incubation: Incubate the plate for the desired treatment duration (e.g., 24, 48, or 72 hours).
- Viability Assay: Perform a cell viability assay such as the MTT or CellTiter-Glo® assay according to the manufacturer's instructions.
- Data Analysis: Measure the absorbance or luminescence and normalize the data to the vehicle control. Plot the percentage of cell viability against the log of the **LY2365109** concentration to determine the IC50 value.

## Protocol 2: Assessing the Effect of **LY2365109** on NMDA Receptor-Mediated Calcium Influx

- Cell Plating: Plate neurons on glass-bottom dishes or 96-well imaging plates suitable for fluorescence microscopy.
- Calcium Indicator Loading: Load the cells with a calcium indicator dye (e.g., Fluo-4 AM) according to the manufacturer's protocol.
- **LY2365109** Pre-incubation: Replace the dye-loading solution with a recording buffer containing the desired concentration of **LY2365109** (and a vehicle control). Incubate for a short period (e.g., 15-30 minutes) to allow for GlyT1 inhibition.
- Baseline Measurement: Acquire a baseline fluorescence measurement using a fluorescence microscope or plate reader.
- NMDA Stimulation: Add a solution of NMDA and glycine to the wells to stimulate the NMDA receptors.
- Data Acquisition: Record the change in fluorescence intensity over time.
- Data Analysis: Quantify the peak fluorescence intensity or the area under the curve for each condition. Compare the response in the presence of **LY2365109** to the vehicle control to determine the potentiation of NMDA receptor activity.

## Visualizations

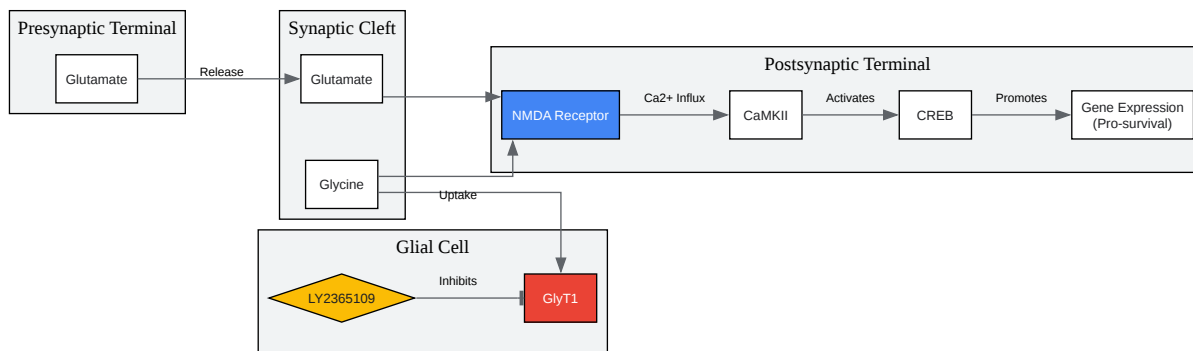

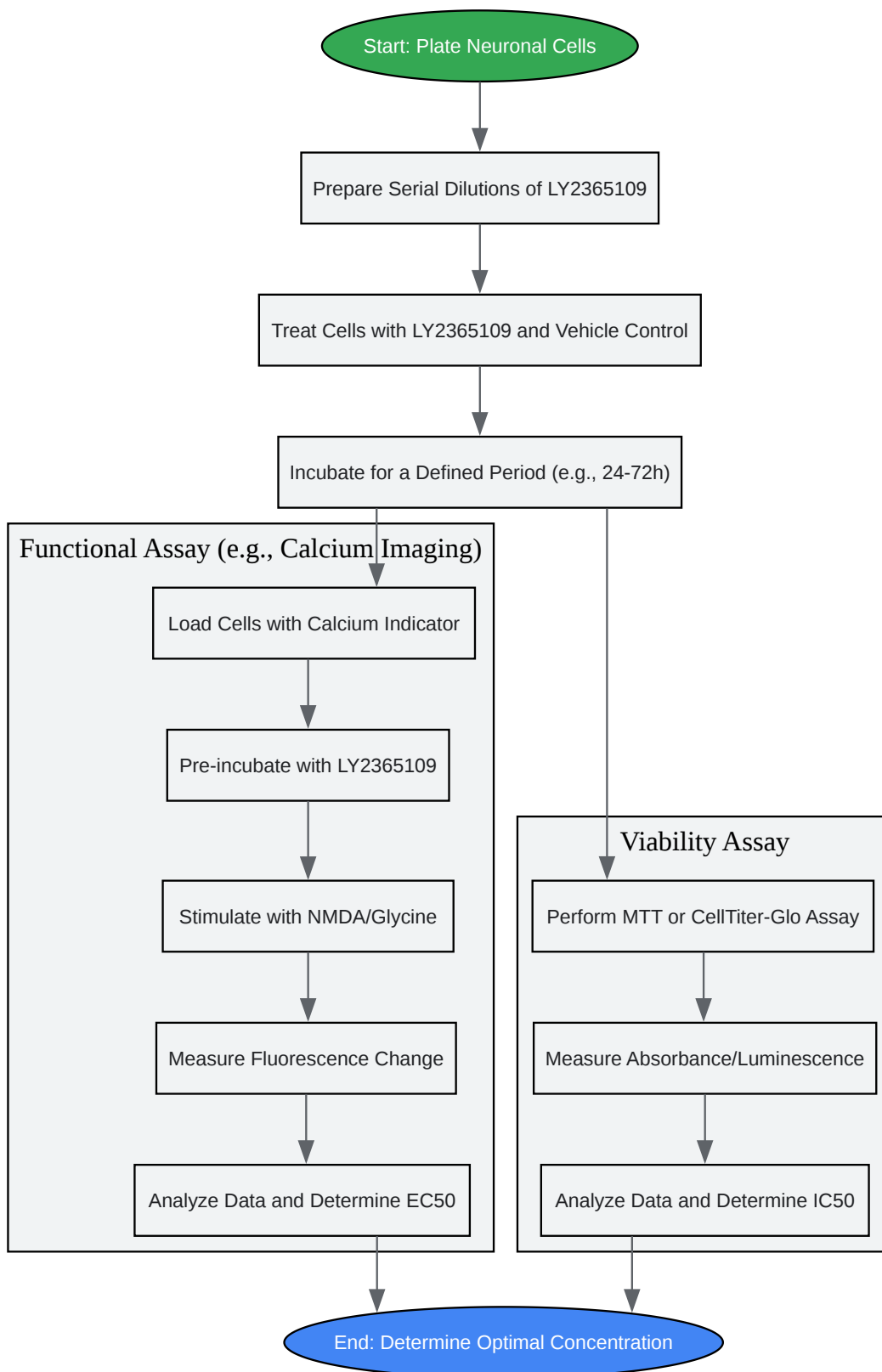

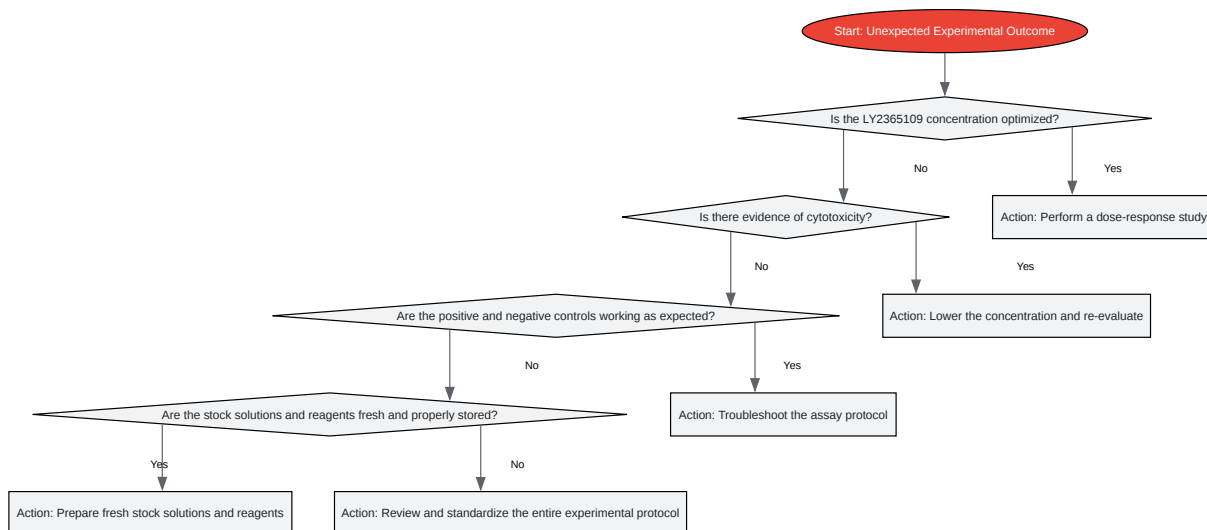

[Click to download full resolution via product page](#)

### Need Custom Synthesis?

BenchChem offers custom synthesis for rare earth carbides and specific isotopic labeling.

Email: [info@benchchem.com](mailto:info@benchchem.com) or [Request Quote Online](#).

## References

- 1. Neurochemical, electrophysiological and pharmacological profiles of the selective inhibitor of the glycine transporter-1 SSR504734, a potential new type of antipsychotic - PubMed

[\[pubmed.ncbi.nlm.nih.gov\]](https://pubmed.ncbi.nlm.nih.gov)

- [2. Neurochemical and behavioral profiling of the selective GlyT1 inhibitors ALX5407 and LY2365109 indicate a preferential action in caudal vs. cortical brain areas - PubMed](#)  
[\[pubmed.ncbi.nlm.nih.gov\]](https://pubmed.ncbi.nlm.nih.gov)
- To cite this document: BenchChem. [Technical Support Center: Optimizing LY2365109 Concentration for Neuronal Cell Cultures]. BenchChem, [2026]. [Online PDF]. Available at: [\[https://www.benchchem.com/product/b15616539/docs#technical-support-center-optimizing-ly2365109-concentration-for-neuronal-cell-cultures\]](https://www.benchchem.com/product/b15616539/docs#technical-support-center-optimizing-ly2365109-concentration-for-neuronal-cell-cultures)

---

### Disclaimer & Data Validity:

The information provided in this document is for Research Use Only (RUO) and is strictly not intended for diagnostic or therapeutic procedures. While BenchChem strives to provide accurate protocols, we make no warranties, express or implied, regarding the fitness of this product for every specific experimental setup.

**Technical Support:** The protocols provided are for reference purposes. Unsure if this reagent suits your experiment?

**Need Industrial/Bulk Grade?** [Request Custom Synthesis Quote](#)

## BenchChem

Our mission is to be the trusted global source of essential and advanced chemicals, empowering scientists and researchers to drive progress in science and industry.

### Contact

Address: 3281 E Guasti Rd  
Ontario, CA 91761, United States  
Phone: (601) 213-4426  
Email: [info@benchchem.com](mailto:info@benchchem.com)

[Contact our Ph.D. Support Team for a compatibility check](#)

