

# FR252384 stability in different experimental buffers

**Author:** BenchChem Technical Support Team. **Date:** May 2026

## Compound of Interest

Compound Name: FR252384

Cat. No.: B15616698

[Get Quote](#)

## FR252384 Technical Support Center

Welcome to the technical support center for **FR252384**. This resource is designed for researchers, scientists, and drug development professionals to provide guidance on the stability of **FR252384** in various experimental buffers and to address common issues encountered during its use.

## Frequently Asked Questions (FAQs)

Q1: What is **FR252384** and what is its mechanism of action?

**FR252384** is a potent inhibitor of the Interleukin-2 (IL-2) and Interleukin-15 (IL-15) signaling pathways. These cytokines play crucial roles in the proliferation and activation of T cells and Natural Killer (NK) cells.<sup>[1][2][3]</sup> Both IL-2 and IL-15 share common receptor subunits (IL-2/IL-15R $\beta$  and the common gamma chain,  $\gamma$ c) and activate similar downstream signaling cascades, most notably the JAK/STAT pathway.<sup>[1][2]</sup> By blocking these pathways, **FR252384** can modulate immune responses, making it a valuable tool for research in immunology and oncology.

Q2: Is there quantitative data available on the stability of **FR252384** in common experimental buffers?

Currently, there is limited publicly available quantitative data, such as half-life or degradation rates, on the stability of **FR252384** in specific experimental buffers like Phosphate-Buffered Saline (PBS), Tris-HCl, or cell culture media. The stability of a compound can be influenced by several factors including pH, buffer composition, temperature, and light exposure.

Q3: How can I determine the stability of **FR252384** in my specific experimental buffer?

Since pre-existing stability data is limited, it is highly recommended to perform an in-house stability assessment in your buffer of choice under your experimental conditions. A general protocol to determine compound stability using High-Performance Liquid Chromatography (HPLC) or Liquid Chromatography-Mass Spectrometry (LC-MS) is provided in the "Experimental Protocols" section below. This will allow you to generate reliable data for your specific experimental setup.

Q4: What are the general recommendations for preparing and storing **FR252384** solutions?

To ensure the integrity of **FR252384**, follow these general guidelines:

- **Stock Solutions:** Prepare high-concentration stock solutions in an anhydrous organic solvent such as Dimethyl Sulfoxide (DMSO). Store these stock solutions in small aliquots at -20°C or -80°C to minimize freeze-thaw cycles.
- **Working Solutions:** When preparing aqueous working solutions, it is best practice to make them fresh for each experiment. Dilute the stock solution into your pre-warmed experimental buffer immediately before use.
- **pH Considerations:** The stability of compounds can be pH-dependent. While specific data for **FR252384** is unavailable, it is advisable to maintain a consistent pH in your experiments and consider potential pH shifts in your buffer system over time.
- **Light Sensitivity:** Protect solutions from direct light, especially during long-term storage and incubation, by using amber vials or covering the containers with aluminum foil.

Q5: I am observing inconsistent or lower-than-expected activity of **FR252384** in my experiments. What could be the cause?

Inconsistent results are often an indication of compound instability in the experimental setup. This could be due to degradation of **FR252384** in your aqueous buffer at the experimental temperature. It is also possible that the compound is precipitating out of solution. Please refer to the Troubleshooting Guide below for a systematic approach to resolving this issue.

## Troubleshooting Guide

Issue	Potential Cause	Recommended Action
Inconsistent or reduced biological activity	Compound degradation in the experimental buffer.	Perform a stability study of FR252384 in your buffer using the protocol provided below. Prepare fresh working solutions for each experiment.
Compound precipitation from the aqueous buffer.	Visually inspect the solution for any precipitate. To prevent precipitation, ensure the final concentration of the organic solvent (e.g., DMSO) is low (typically <0.5%), pre-warm the aqueous buffer before adding the compound stock, and add the stock solution dropwise while vortexing.	
Incorrect storage of stock or working solutions.	Review storage conditions. Store stock solutions in small aliquots at -20°C or -80°C. Avoid repeated freeze-thaw cycles. Prepare aqueous working solutions fresh.	
Precipitate forms upon dilution into aqueous buffer	"Solvent-shift" precipitation due to poor aqueous solubility.	Pre-warm your experimental buffer to the working temperature (e.g., 37°C). Add the DMSO stock solution dropwise to the buffer while vortexing to ensure rapid mixing. Consider using a lower final concentration of FR252384 if solubility is a persistent issue.
Variability between experiments	Inconsistent preparation of FR252384 solutions.	Standardize the protocol for preparing FR252384 solutions, including the age of the stock

solution and the method of dilution.

Degradation of the compound due to light exposure. Protect all solutions containing FR252384 from light by using amber tubes or wrapping them in foil.

## Data Presentation

As specific quantitative stability data for **FR252384** is not publicly available, we provide the following table templates for you to summarize your own experimental findings.

Table 1: Stability of **FR252384** in Various Buffers at 37°C

Buffer System	pH	Incubation Time (hours)	% Remaining FR252384	Half-life (t <sub>1/2</sub> ) (hours)
PBS	7.4	0	100	Calculate
2	Your Data			
8	Your Data			
24	Your Data			
Tris-HCl	7.4	0	100	Calculate
2	Your Data			
8	Your Data			
24	Your Data			
RPMI + 10% FBS	~7.2-7.4	0	100	Calculate
2	Your Data			
8	Your Data			
24	Your Data			

Table 2: Effect of pH on **FR252384** Stability in PBS at 37°C

pH	Incubation Time (hours)	% Remaining <b>FR252384</b>	Half-life ( $t_{1/2}$ ) (hours)
5.0	0	100	Calculate
8	Your Data		
24	Your Data		
7.4	0	100	Calculate
8	Your Data		
24	Your Data		
8.5	0	100	Calculate
8	Your Data		
24	Your Data		

## Experimental Protocols

### Protocol 1: Assessing the Stability of **FR252384** in an Aqueous Buffer

This protocol outlines a general method to determine the stability of **FR252384** in a specific buffer using HPLC or LC-MS.

Materials:

- **FR252384**
- Anhydrous DMSO
- Your experimental buffer of choice (e.g., PBS, Tris-HCl, cell culture medium)
- Quenching solution (e.g., ice-cold Acetonitrile with 0.1% formic acid)

- HPLC or LC-MS system with a suitable column (e.g., C18)

#### Methodology:

- Prepare a Stock Solution: Prepare a 10 mM stock solution of **FR252384** in 100% DMSO.
- Prepare the Test Solution: Dilute the **FR252384** stock solution into your pre-warmed experimental buffer to the final working concentration (e.g., 10  $\mu$ M). Ensure the final DMSO concentration is low (e.g., <0.1%).
- Timepoint Zero (T=0): Immediately after preparation, take an aliquot (e.g., 100  $\mu$ L) of the test solution and add it to a vial containing a larger volume of ice-cold quenching solution (e.g., 900  $\mu$ L). This will stop any degradation. Store this sample at -20°C or colder until analysis.
- Incubation: Incubate the remaining test solution under your standard experimental conditions (e.g., 37°C in a cell culture incubator). Protect the solution from light.
- Collect Timepoints: At various time intervals (e.g., 1, 4, 8, 24 hours), remove an aliquot of the test solution and quench it in the same manner as the T=0 sample.
- Sample Analysis: Analyze all the collected samples by HPLC or LC-MS. The goal is to separate the parent **FR252384** compound from any potential degradation products.
- Data Analysis: Determine the peak area of the intact **FR252384** at each time point. Calculate the percentage of **FR252384** remaining at each time point relative to the peak area at T=0. This data can then be used to calculate the half-life of the compound in your buffer.

## Mandatory Visualizations

### Signaling Pathway

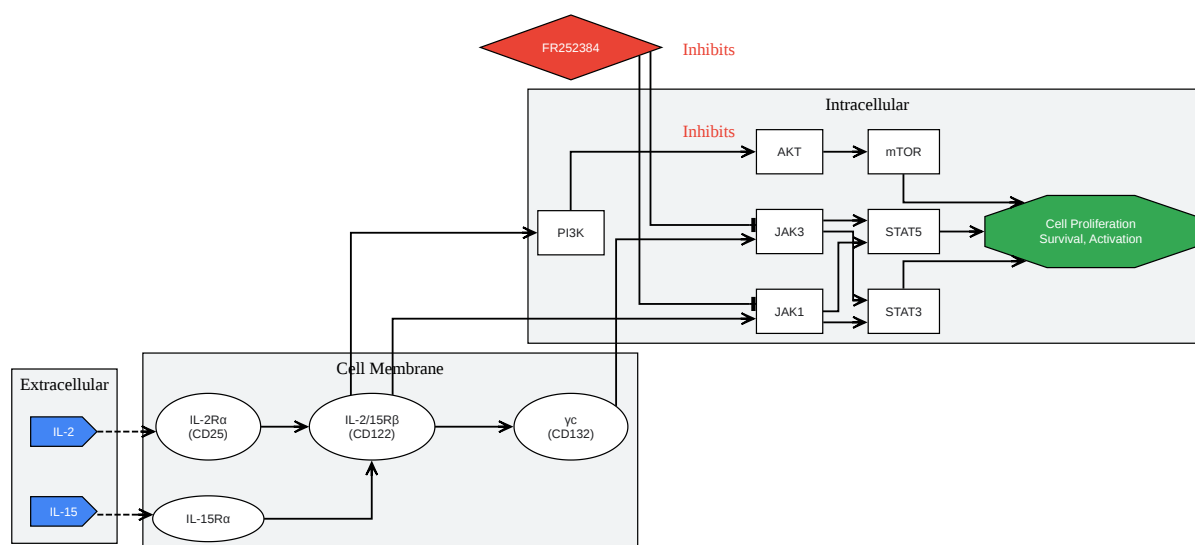

[Click to download full resolution via product page](#)

Caption: IL-2 and IL-15 signaling pathway inhibited by **FR252384**.

## Experimental Workflow

Caption: Troubleshooting workflow for **FR252384** stability issues.

### Need Custom Synthesis?

BenchChem offers custom synthesis for rare earth carbides and specific isotopic labeling.

Email: [info@benchchem.com](mailto:info@benchchem.com) or [Request Quote Online](#).

## References

- [1. Inhibiting IL-2 signaling and the regulatory T-cell pathway using computationally designed peptides - PubMed \[pubmed.ncbi.nlm.nih.gov\]](#)
- [2. Engineered Interleukin-2 Antagonists for the Inhibition of Regulatory T cells - PMC \[pmc.ncbi.nlm.nih.gov\]](#)
- [3. researchgate.net \[researchgate.net\]](#)
- To cite this document: BenchChem. [FR252384 stability in different experimental buffers]. BenchChem, [2026]. [Online PDF]. Available at: [\[https://www.benchchem.com/product/b15616698/docs#fr252384-stability-in-different-experimental-buffers\]](https://www.benchchem.com/product/b15616698/docs#fr252384-stability-in-different-experimental-buffers)

---

### Disclaimer & Data Validity:

The information provided in this document is for Research Use Only (RUO) and is strictly not intended for diagnostic or therapeutic procedures. While BenchChem strives to provide accurate protocols, we make no warranties, express or implied, regarding the fitness of this product for every specific experimental setup.

**Technical Support:** The protocols provided are for reference purposes. Unsure if this reagent suits your experiment?

**Need Industrial/Bulk Grade?** [Request Custom Synthesis Quote](#)

## BenchChem

Our mission is to be the trusted global source of essential and advanced chemicals, empowering scientists and researchers to drive progress in science and industry.

### Contact

Address: 3281 E Guasti Rd

Ontario, CA 91761, United States

Phone: (601) 213-4426

Email: [info@benchchem.com](mailto:info@benchchem.com)

Contact our Ph.D. Support Team for a compatibility check