

# A Technical Guide to the Function of Mini Gastrin I in Humans

**Author:** BenchChem Technical Support Team. **Date:** April 2026

## Compound of Interest

Compound Name: *Mini Gastrin I, human*

Cat. No.: *B15616002*

[Get Quote](#)

Authored for: Researchers, Scientists, and Drug Development Professionals

## Abstract

Mini Gastrin I, a potent isoform of the peptide hormone gastrin, plays a significant role in human physiology, primarily through its interaction with the cholecystokinin B (CCK2) receptor. While its endogenous functions include the regulation of gastric acid secretion and mucosal growth, the overexpression of its target receptor, CCK2R, in various malignancies has pivoted Mini Gastrin I and its synthetic analogues into the forefront of oncological research. This document provides a comprehensive overview of the molecular function of Mini Gastrin I, its signaling pathways, and its modern application as a targeting agent for cancer theranostics. Detailed experimental protocols and quantitative data from key preclinical studies are presented to serve as a resource for professionals in the field.

## Introduction to Mini Gastrin I

Gastrin is a critical peptide hormone responsible for stimulating gastric acid secretion and promoting the growth of the gastric mucosa.[1][2] It exists in several molecular forms, synthesized as a prohormone and processed into various active peptides.[3] The primary

circulating form is Gastrin-34 ("big gastrin"), which can be cleaved into the 17-amino acid Gastrin-17 ("little gastrin").[3]

Mini Gastrin I (also known as Gastrin-13 or G-13) is a shorter, biologically active form of human gastrin, corresponding to amino acids 5-17 of Gastrin-17.[4][5][6] Its primary function is mediated through high-affinity binding to the cholecystokinin B receptor (CCKBR), also known as the CCK2 receptor, a G protein-coupled receptor (GPCR) found in the stomach and central nervous system.[2][7][8] While physiologically important, the main interest in Mini Gastrin I for drug development stems from the high expression of CCK2R in tumors such as medullary thyroid carcinoma (MTC) and small-cell lung cancer, making it an ideal vector for targeted cancer diagnosis and therapy.[9][10][11]

## Physiological Functions and Bioactivity

The core physiological role of gastrins, including Mini Gastrin I, is the regulation of gastric function.

- **Stimulation of Gastric Acid Secretion:** Gastrin binds to CCK2 receptors on enterochromaffin-like (ECL) cells, triggering the release of histamine. Histamine, in turn, binds to H2 receptors on parietal cells, leading to the secretion of gastric acid (HCl).[2] Gastrin also directly stimulates parietal cells.[2]
- **Trophic Effects:** Gastrin promotes the growth and maintenance of the gastric mucosa by stimulating DNA, RNA, and protein synthesis, thereby increasing the number of parietal cells.[2][12]
- **Gastrointestinal Motility:** The hormone also influences the proper mixing and movement of food through the stomach.[2][12]

Early studies in canine models demonstrated that while Mini Gastrin I (HG-13-I) effectively stimulates acid secretion, its potency is lower than that of Gastrin-17 (HG-17-I). The peptide exhibits a very short half-life in circulation.[13]

## Data Presentation: Bioactivity and Pharmacokinetics

Table 1: Comparative Potency and Pharmacokinetics of Mini Gastrin I vs. Gastrin-17 in a Canine Model

Parameter	Mini Gastrin I (HG-13-I)	Gastrin-17 (HG-17-I)	Reference
Acid Secretion Potency Ratio	0.4 (95% CI: 0.2 - 0.6)	1.0 (Reference)	[13]
Half-life in Blood	1.8 minutes	Similar to HG-13-I	[13]
Volume of Distribution	0.17 L/kg	Similar to HG-13-I	[13]

Data derived from a continuous intravenous infusion study in dogs with gastric fistulae.[13]

## Molecular Signaling Pathways

Mini Gastrin I exerts its effects by activating the CCK2 receptor, which couples to downstream signaling cascades. The primary pathways involve Gq proteins leading to calcium mobilization and mitogen-activated protein kinase (MAPK) activation for cell growth.

### Gq-Mediated Phospholipase C Pathway

Upon ligand binding, the CCK2 receptor activates the G $\alpha$ q subunit of its associated G protein. This initiates a cascade that increases intracellular calcium, a key second messenger for stimulating gastric acid secretion from parietal cells.[2][7]

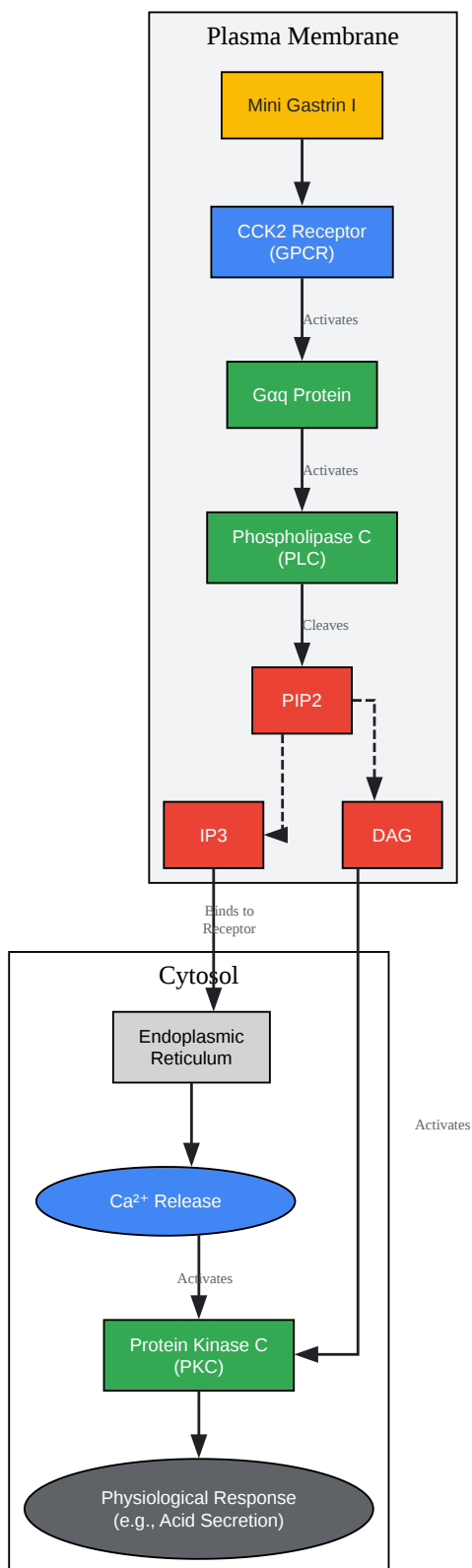

[Click to download full resolution via product page](#)

**Caption:** Gq-protein signaling cascade upon Mini Gastrin I binding.

## Mitogenic Signaling via MAPK/ERK Pathway

The trophic effects of Mini Gastrin I are mediated by pathways that promote cell growth and proliferation, such as the MAPK/ERK pathway. This activation can be dependent on both Protein Kinase C (PKC) and Phosphoinositide 3-kinase (PI3K).[14] Stimulation of the CCK2R with minigastrin analogues has been shown to increase the phosphorylation of ERK1/2.[11]

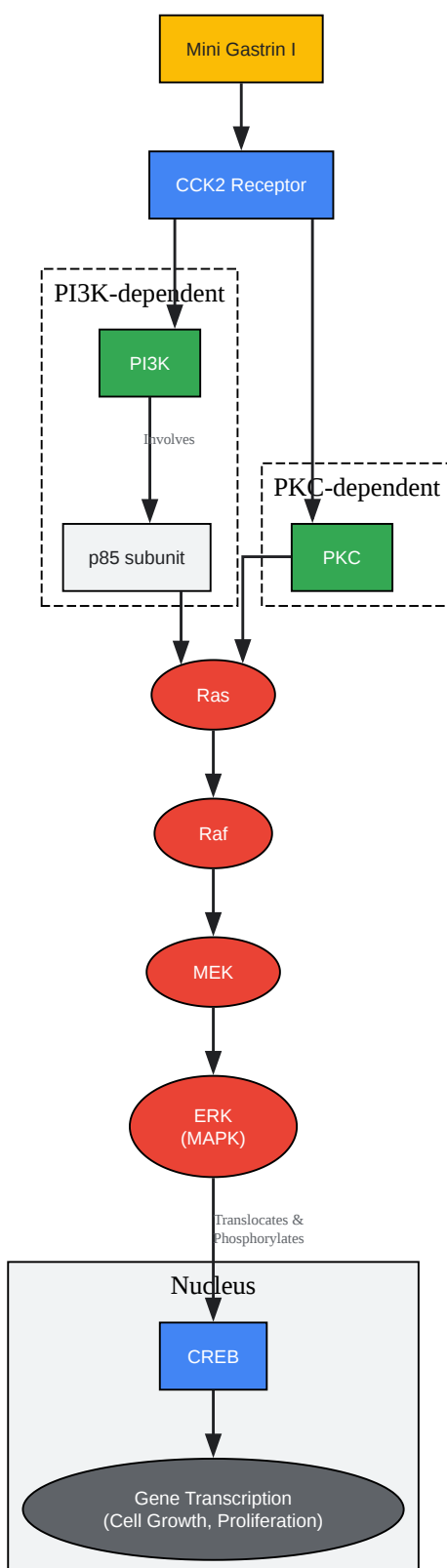

[Click to download full resolution via product page](#)

**Caption:** Mitogenic signaling via the PI3K/PKC and MAPK/ERK pathways.

## Application in Oncology: Targeting the CCK2 Receptor

The high incidence of CCK2R expression on various tumors has made it a prime target for peptide receptor radionuclide therapy (PRRT).[9] Mini Gastrin I analogues are chemically modified to improve stability and are chelated with radioisotopes for imaging (e.g., <sup>68</sup>Ga, <sup>111</sup>In) or therapy (e.g., <sup>177</sup>Lu, <sup>225</sup>Ac).[15][16][17]

## Data Presentation: Preclinical Efficacy of Minigastrin Analogues

The following tables summarize representative quantitative data from preclinical studies on various synthetic Mini Gastrin I analogues designed for tumor targeting.

Table 2: In Vitro Characteristics of Representative Radiolabeled Minigastrin Analogues

Analogue	Cell Line	IC <sub>50</sub> (nM)	Internalization (4h, %)	Reference
[ <sup>111</sup> In]In-DOTA-cyclo-MG1	A431-CCK2R	-	15.2 ± 2.6 (at 2h)	[18]
[ <sup>111</sup> In]In-DOTA-MGS5	A431-CCK2R	2.5 ± 0.9	47.3 ± 8.1	[9]
[ <sup>111</sup> In]In-Compound 1	A431-CCK2R	-	≥60%	[16]
[ <sup>111</sup> In]In-Compound 2	A431-CCK2R	-	≥60%	[16]

IC<sub>50</sub> values represent the concentration required to inhibit 50% of specific binding.

Internalization reflects receptor-mediated uptake into tumor cells.

Table 3: In Vivo Tumor Uptake of <sup>177</sup>Lu-Labeled Minigastrin Analogues in A431-CCK2R Xenografts

Analogue	Time p.i. (h)	Tumor Uptake (% IA/g)	Tumor-to-Kidney Ratio	Reference
[ <sup>177</sup> Lu]Lu-DOTA-cyclo-MG1	4	3.50 ± 0.78	-	[18]
[ <sup>177</sup> Lu]Lu-Compound 1	4	34.72 ± 9.40	~5.7	[16]
[ <sup>177</sup> Lu]Lu-Compound 2	4	33.25 ± 6.34	~7.9	[16]
[ <sup>177</sup> Lu]Lu-PP-F11N + RAD001	24	~25 (Enhanced uptake)	~2.5	[11]

% IA/g = percentage of injected activity per gram of tissue. Data from BALB/c nude mice bearing A431-CCK2R tumors.

Table 4: Therapeutic Efficacy of Radiolabeled Minigastrin Analogues in Xenograft Models

Analogue / Treatment	Model	Key Outcome	Reference
DOTA-PP-F11N + Everolimus	A431/CCKBR Mice	Median survival increased from 19.5 to 43 days.	[10]
[ <sup>177</sup> Lu]Lu-DOTA-CCK-66	MTC Xenograft Mice	Mean survival increased from 12 to 37 days.	[17]
[ <sup>225</sup> Ac]Ac-DOTA-CCK-66	MTC Xenograft Mice	Mean survival increased from 12 to 54 days.	[17]

Studies demonstrate significant tumor growth inhibition and increased survival in treated animals compared to controls.

## Key Experimental Protocols

The characterization of novel Mini Gastrin I analogues relies on a standardized set of in vitro and in vivo assays.

### Protocol: Competitive Binding Assay

This assay determines the binding affinity ( $IC_{50}$ ) of a non-radiolabeled peptide by measuring its ability to compete with a radiolabeled ligand for receptor binding.

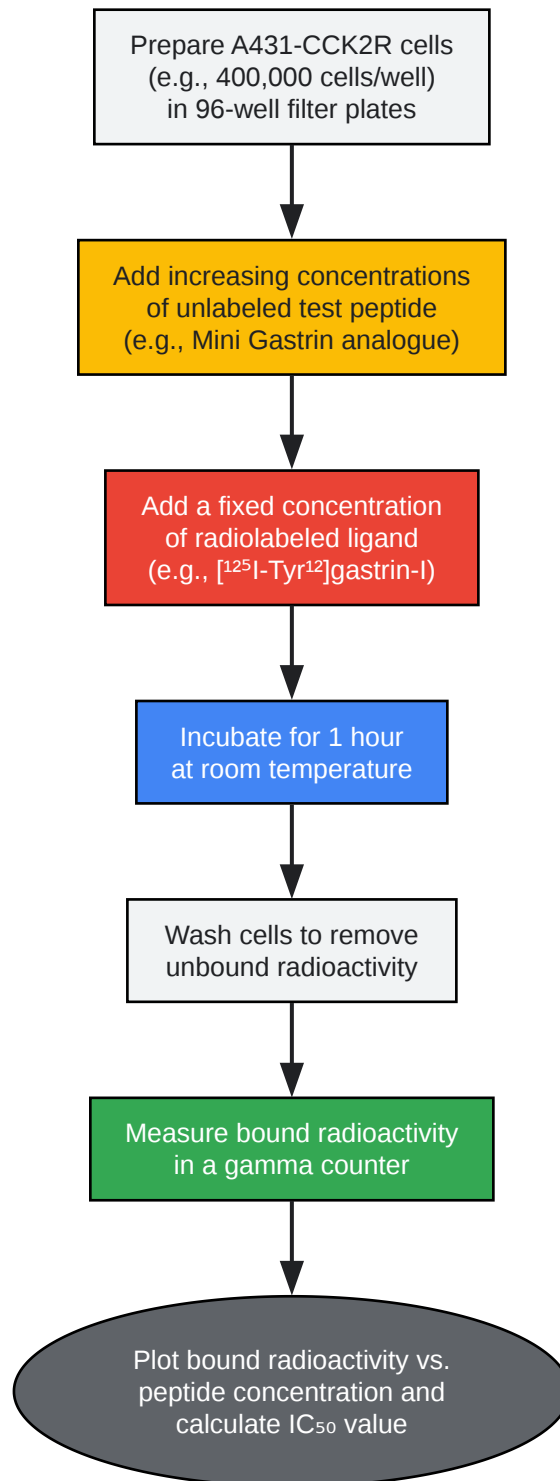

[Click to download full resolution via product page](#)

**Caption:** Workflow for a competitive binding assay.

Detailed Methodology (based on[18]):

- Plate Preparation: Pre-treat 96-well filter plates with a binding buffer (e.g., 10 mM TRIS/139 mM NaCl, pH 7.4).
- Cell Seeding: Add 400,000 A431-CCK2R cells per well suspended in an assay buffer (e.g., 35 mM HEPES, 10 mM MgCl<sub>2</sub>, 14 μM bacitracin, 0.5% BSA).
- Incubation: Add triplicate wells of increasing concentrations of the unlabeled test analogue (0.0003-1,000 nM) and a constant amount of a radiolabeled competitor like [<sup>125</sup>I-Tyr<sup>12</sup>]gastrin-I (~50,000 cpm). Incubate for 1 hour at room temperature.
- Washing: Aspirate the buffer and wash the cells to separate bound from free radioligand.
- Measurement: Measure the radioactivity retained on the filter using a gamma counter.
- Analysis: Plot the data using non-linear regression to determine the IC<sub>50</sub> value.

## Protocol: In Vitro Cell Internalization Assay

This assay quantifies the amount of radiolabeled peptide that is actively transported into the target cells over time.

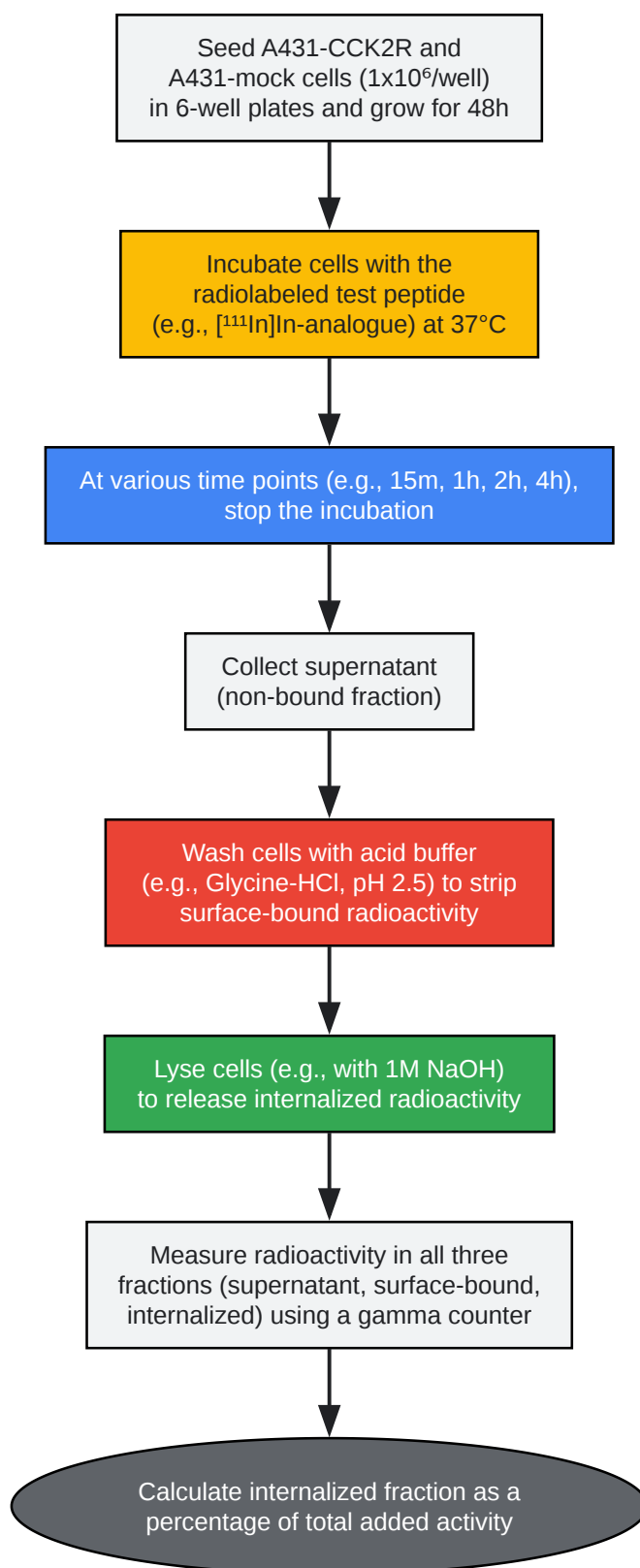

[Click to download full resolution via product page](#)

**Caption:** Workflow for an in vitro cell internalization assay.

Detailed Methodology (based on[9][16]):

- Cell Culture: Seed A431-CCK2R (receptor-positive) and A431-mock (negative control) cells in 6-well plates and allow them to adhere for 48 hours.
- Incubation: Remove the culture medium and add the radiolabeled peptide diluted in fresh medium. Incubate at 37°C for various durations (e.g., 15, 60, 120, 240 minutes).
- Fractionation:
  - Non-Bound: At each time point, collect the supernatant.
  - Surface-Bound: Wash the cells with an acidic buffer (e.g., 50 mM glycine-HCl, pH 2.5) twice to strip off non-internalized, receptor-bound radioligand. Collect these washes.
  - Internalized: Lyse the cells with 1M NaOH to release the intracellular radioactivity. Collect the lysate.
- Measurement: Measure the radioactivity in all collected fractions using a gamma counter.
- Analysis: Express the internalized radioactivity as a percentage of the total radioactivity initially added to the well.

## Conclusion

Mini Gastrin I is a multifaceted peptide hormone. In physiology, it is a key regulator of gastric acid secretion and mucosal integrity. In modern biomedical research, its role has been transformed. The specific interaction between Mini Gastrin I and the CCK2 receptor provides a powerful molecular axis to exploit for oncological applications. Synthetic analogues of Mini Gastrin I, optimized for stability and labeled with radionuclides, have shown exceptional promise in preclinical models for the targeted imaging and radiotherapy of CCK2R-positive tumors. Ongoing research focuses on further refining these analogues to enhance tumor-to-organ ratios and maximize therapeutic efficacy, heralding a new frontier in personalized nuclear medicine.

### Need Custom Synthesis?

BenchChem offers custom synthesis for rare earth carbides and specific isotopic labeling.

Email: [info@benchchem.com](mailto:info@benchchem.com) or [Request Quote Online](#).

## References

- [1. eurekaselect.com](http://eurekaselect.com) [eurekaselect.com]
- [2. Gastrin](http://vivo.colostate.edu) [vivo.colostate.edu]
- [3. Gastrin-17 \(G17\) Antibodies and Antigens - Creative Diagnostics](http://creative-diagnostics.com) [creative-diagnostics.com]
- [4. medchemexpress.com](http://medchemexpress.com) [medchemexpress.com]
- [5. Minigastrin I, human - Echelon Biosciences](http://echelon-inc.com) [echelon-inc.com]
- [6. peptide.com](http://peptide.com) [peptide.com]
- [7. uniprot.org](http://uniprot.org) [uniprot.org]
- [8. Cholecystokinin B receptor - Wikipedia](http://en.wikipedia.org) [en.wikipedia.org]
- [9. pdfs.semanticscholar.org](http://pdfs.semanticscholar.org) [pdfs.semanticscholar.org]
- [10. Minigastrin - Wikipedia](http://en.wikipedia.org) [en.wikipedia.org]
- [11. Pharmacological inhibition of mTORC1 increases CCKBR-specific tumor uptake of radiolabeled minigastrin analogue \[177Lu\]Lu-PP-F11N - PMC](http://pmc.ncbi.nlm.nih.gov) [pmc.ncbi.nlm.nih.gov]
- [12. Gastrin-17: A Key Hormone in Digestion and Its Diagnostic Importance - Xiamen Wiz Biotech Co., Ltd](http://wizbiotech.net) [wizbiotech.net]
- [13. Pure human minigastrin: secretory potency and disappearance rate - PubMed](http://pubmed.ncbi.nlm.nih.gov) [pubmed.ncbi.nlm.nih.gov]
- [14. Different signaling pathways are involved in CCK\(B\) receptor-mediated MAP kinase activation in COS-7 cells - PubMed](http://pubmed.ncbi.nlm.nih.gov) [pubmed.ncbi.nlm.nih.gov]
- [15. Preclinical Evaluation of Minigastrin Analogs and Proof-of-Concept \[68Ga\]Ga-DOTA-CCK-66 PET/CT in 2 Patients with Medullary Thyroid Cancer - PMC](http://pmc.ncbi.nlm.nih.gov) [pmc.ncbi.nlm.nih.gov]
- [16. pubs.acs.org](http://pubs.acs.org) [pubs.acs.org]
- [17. Preclinical evaluation of 225Ac-labeled minigastrin analog DOTA-CCK-66 for Targeted Alpha Therapy - PMC](http://pmc.ncbi.nlm.nih.gov) [pmc.ncbi.nlm.nih.gov]

- [18. <sup>177</sup>Lu labelled cyclic minigastrin analogues with therapeutic activity in CCK2R expressing tumours, preclinical evaluation of a kit formulation - PMC \[pmc.ncbi.nlm.nih.gov\]](#)
- To cite this document: BenchChem. [A Technical Guide to the Function of Mini Gastrin I in Humans]. BenchChem, [2026]. [Online PDF]. Available at: [<https://www.benchchem.com/product/b15616002/docs#a-technical-guide-to-the-function-of-mini-gastrin-i-in-humans>]

---

**Disclaimer & Data Validity:**

The information provided in this document is for Research Use Only (RUO) and is strictly not intended for diagnostic or therapeutic procedures. While BenchChem strives to provide accurate protocols, we make no warranties, express or implied, regarding the fitness of this product for every specific experimental setup.

**Technical Support:** The protocols provided are for reference purposes. Unsure if this reagent suits your experiment?

**Need Industrial/Bulk Grade?** [Request Custom Synthesis Quote](#)

## BenchChem

Our mission is to be the trusted global source of essential and advanced chemicals, empowering scientists and researchers to drive progress in science and industry.

### Contact

Address: 3281 E Guasti Rd  
Ontario, CA 91761, United States  
Phone: (601) 213-4426  
Email: [info@benchchem.com](mailto:info@benchchem.com)

[Contact our Ph.D. Support Team for a compatibility check](#)