

A Comparative Analysis of GABAA Receptor Subunit Selectivity: MRK-898 vs. Zolpidem

Author: BenchChem Technical Support Team. **Date:** April 2026

Compound of Interest

Compound Name: MRK-898
Cat. No.: B15616046

[Get Quote](#)

For Researchers, Scientists, and Drug Development Professionals

This guide provides a detailed comparison of the GABAA receptor subunit selectivity of two prominent modulators: **MRK-898**, a novel anxiolytic candidate, and Zolpidem, a widely prescribed hypnotic agent. Understanding the distinct subunit interaction profiles of these compounds is crucial for the rational design of next-generation therapeutics with improved efficacy and side-effect profiles.

Introduction

The γ -aminobutyric acid type A (GABAA) receptor, a ligand-gated ion channel, is the primary mediator of fast inhibitory neurotransmission in the central nervous system.[1] The receptor is a pentameric complex assembled from a variety of subunits (α 1-6, β 1-3, γ 1-3, δ , ϵ , θ , π , and ρ 1-3), with the most common synaptic isoform being composed of two α , two β , and one γ subunit. [2][3] This subunit heterogeneity gives rise to a vast number of GABAA receptor subtypes with distinct pharmacological and physiological properties.

Modulators targeting the benzodiazepine binding site, located at the interface of the α and γ subunits, can exhibit profound selectivity for different α subunit-containing receptors.[4] This selectivity is a key determinant of their clinical effects. Notably, α 1-containing receptors are

primarily associated with sedative and hypnotic effects, whereas α 2- and α 3-containing receptors are linked to anxiolytic and muscle-relaxant properties.[5][6]

This guide will delve into the binding affinities and functional modulation of **MRK-898** and Zolpidem across various GABAA receptor α subunits, supported by experimental data and detailed protocols.

Data Presentation

Quantitative Binding Affinity Data

The following table summarizes the binding affinities (K_i , in nM) of **MRK-898** and Zolpidem for different GABAA receptor α subunits. Lower K_i values indicate higher binding affinity.

Compound	α 1	α 2	α 3	α 5	Reference(s)
MRK-898	1.2	1.0	0.73	0.50	[1][5]
Zolpidem	10-20 (High Affinity)	200-300 (Low Affinity)	200-300 (Low Affinity)	4000-10000 (Very Low Affinity)	[7]

Quantitative Functional Data

The functional potency of a modulator is typically assessed by its ability to enhance the GABA-evoked chloride current. This is quantified by the half-maximal effective concentration (EC_{50}) and the maximum potentiation (E_{max}).

Compound	Receptor Subtype	EC_{50} (nM)	E_{max} (% of GABA response)	Reference(s)
Zolpidem	α 1 β 2 γ 2	184 \pm 56	Not Reported	[8]
Zolpidem	α 1-knockout (α 2/ α 3/ α 5 present)	1096 \pm 279	Not Reported	[8]
MRK-898	α 1/ α 2/ α 3/ α 5	Not Reported	Not Reported	

Note: Specific EC50 and Emax values for **MRK-898** across different α -subunit-containing receptors are not readily available in the public domain. However, it is characterized as an $\alpha 2/$ $\alpha 3$ -selective agonist, implying greater functional potentiation at these subtypes compared to $\alpha 1$.
[6]

Comparative Analysis of Subunit Selectivity

MRK-898 exhibits high affinity binding across $\alpha 1$, $\alpha 2$, $\alpha 3$, and $\alpha 5$ subunits, with a slight preference for $\alpha 5$ and $\alpha 3$. [1][5] Despite its high affinity for the $\alpha 1$ subunit, it was developed as a non-sedating anxiolytic, suggesting that its functional efficacy at the $\alpha 1$ subtype is lower compared to the $\alpha 2$ and $\alpha 3$ subtypes. [6][9] This profile of high affinity but differential efficacy is a key strategy in developing anxiolytic drugs that avoid the sedative effects associated with non-selective benzodiazepines and $\alpha 1$ -preferring compounds like zolpidem.

Zolpidem, in contrast, displays marked selectivity in its binding affinity, with a significantly higher preference for $\alpha 1$ -containing GABAA receptors. [7] It has approximately 10-fold lower affinity for $\alpha 2$ - and $\alpha 3$ -containing receptors and negligible affinity for $\alpha 5$ -containing receptors. [10] This $\alpha 1$ -preferential binding is consistent with its primary clinical use as a hypnotic, as the $\alpha 1$ subunit is strongly implicated in mediating sedation. [8]

Experimental Protocols

Radioligand Binding Assay

This technique is used to determine the binding affinity of a compound for a specific receptor.

Objective: To measure the inhibition constant (K_i) of a test compound (e.g., **MRK-898** or Zolpidem) for a specific GABAA receptor subtype.

Materials:

- Cell membranes expressing the GABAA receptor subtype of interest (e.g., from HEK293 cells transfected with the desired α , β , and γ subunit cDNAs).
- A radiolabeled ligand that binds to the benzodiazepine site with high affinity (e.g., [3 H]flunitrazepam or [3 H]Ro15-1788).
- Test compound (unlabeled).

- Binding buffer (e.g., 50 mM Tris-HCl, pH 7.4).
- Glass fiber filters.
- Scintillation counter.

Procedure:

- **Membrane Preparation:** Homogenize cells expressing the receptor of interest in ice-cold buffer and centrifuge to pellet the membranes. Wash the pellet multiple times to remove endogenous substances. Resuspend the final pellet in binding buffer.[10][11]
- **Assay Setup:** In a multi-well plate, combine the prepared membranes, a fixed concentration of the radioligand, and varying concentrations of the test compound.[11]
- **Incubation:** Incubate the mixture at a specific temperature (e.g., 4°C) for a set period to allow binding to reach equilibrium.[12]
- **Filtration:** Rapidly filter the incubation mixture through glass fiber filters to separate bound from unbound radioligand. Wash the filters with ice-cold buffer to remove non-specifically bound radioligand.[11]
- **Quantification:** Place the filters in scintillation vials with scintillation fluid and measure the radioactivity using a scintillation counter.
- **Data Analysis:** Determine the concentration of the test compound that inhibits 50% of the specific binding of the radioligand (IC50). Calculate the Ki value using the Cheng-Prusoff equation: $K_i = IC_{50} / (1 + [L]/K_d)$, where [L] is the concentration of the radioligand and Kd is its dissociation constant.[11]

Two-Electrode Voltage Clamp (TEVC) Electrophysiology

This method is employed to measure the functional modulation of ion channels, such as the GABAA receptor, by a test compound.

Objective: To determine the EC50 and Emax of a test compound for potentiating GABA-evoked currents at a specific GABAA receptor subtype.

Materials:

- *Xenopus laevis* oocytes.
- cRNA encoding the desired GABAA receptor subunits (α , β , and γ).
- TEVC setup, including a recording chamber, two microelectrodes, a voltage-clamp amplifier, and data acquisition software.
- GABA solution.
- Test compound solution.
- Recording solution (e.g., ND96).

Procedure:

- **Oocyte Preparation and Injection:** Harvest oocytes from a female *Xenopus laevis* frog and inject them with a mixture of cRNAs for the desired GABAA receptor subunits. Incubate the oocytes for 2-7 days to allow for receptor expression.[\[13\]](#)
- **Recording Setup:** Place an oocyte in the recording chamber and perfuse with recording solution. Impale the oocyte with two microelectrodes, one for voltage recording and one for current injection.[\[14\]](#)[\[15\]](#)
- **Voltage Clamp:** Clamp the oocyte membrane potential at a holding potential (e.g., -60 mV).
- **GABA Application:** Apply a low concentration of GABA (typically the EC5-EC20) to elicit a baseline chloride current.
- **Compound Application:** Co-apply the test compound at various concentrations along with the same concentration of GABA and record the potentiated current response.
- **Data Analysis:** Plot the percentage potentiation of the GABA-evoked current as a function of the test compound concentration. Fit the data to a sigmoidal dose-response curve to determine the EC50 and Emax values.[\[2\]](#)

Visualizations

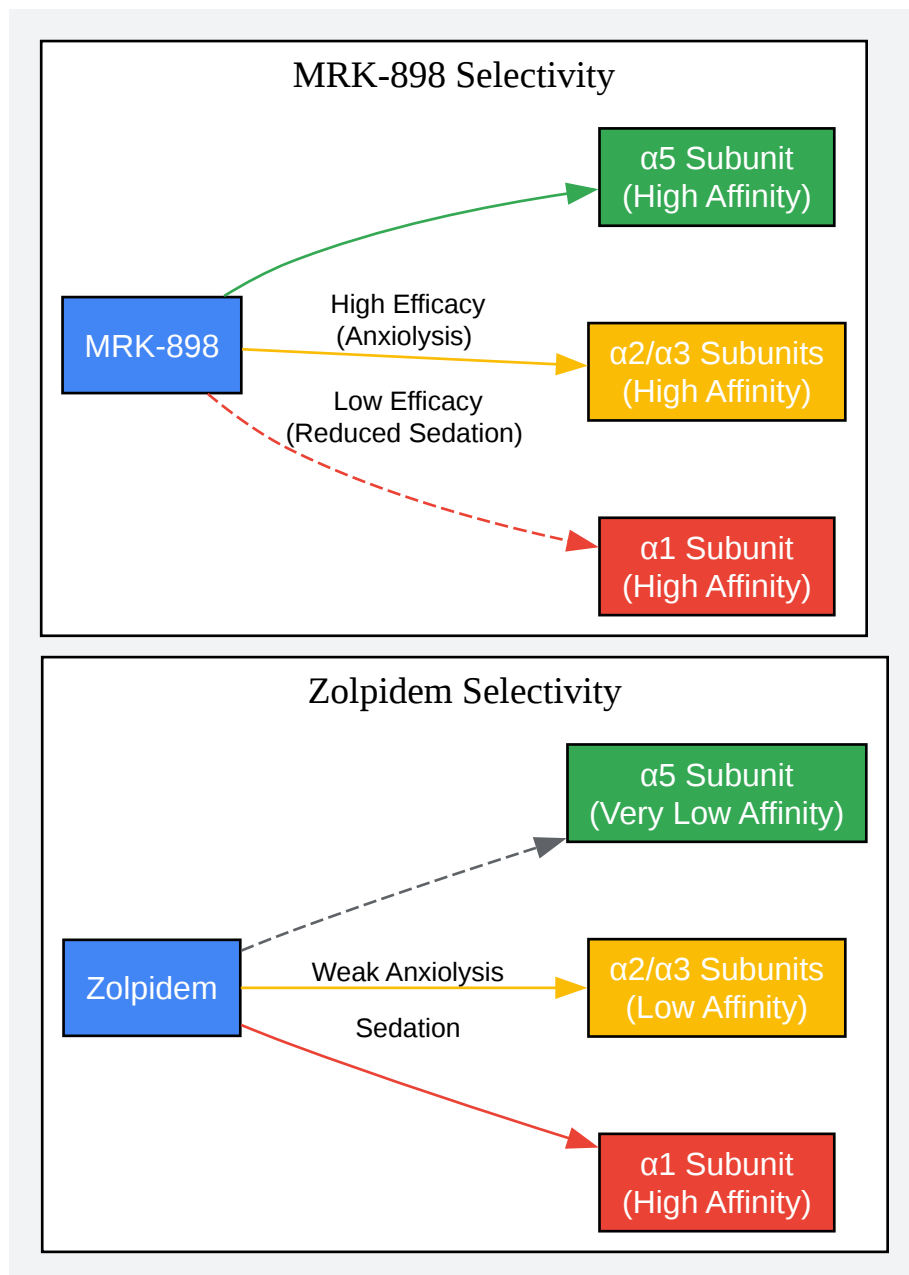

[Click to download full resolution via product page](#)

Caption: Subunit selectivity profiles of Zolpidem and **MRK-898**.

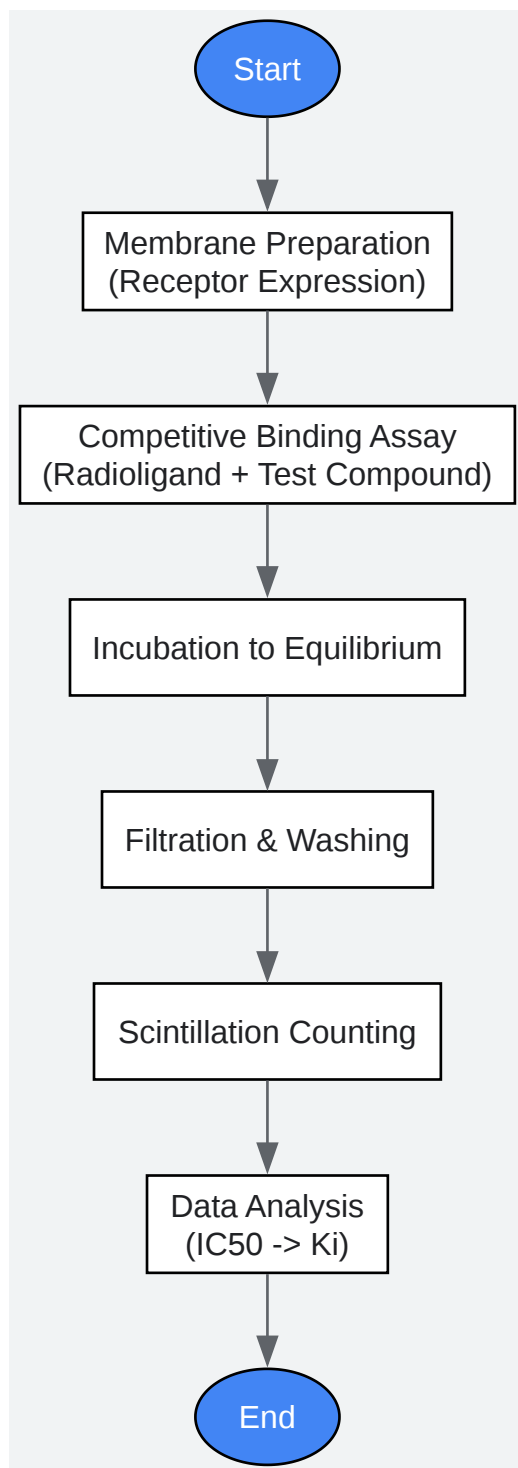

[Click to download full resolution via product page](#)

Caption: Workflow for a radioligand binding assay.

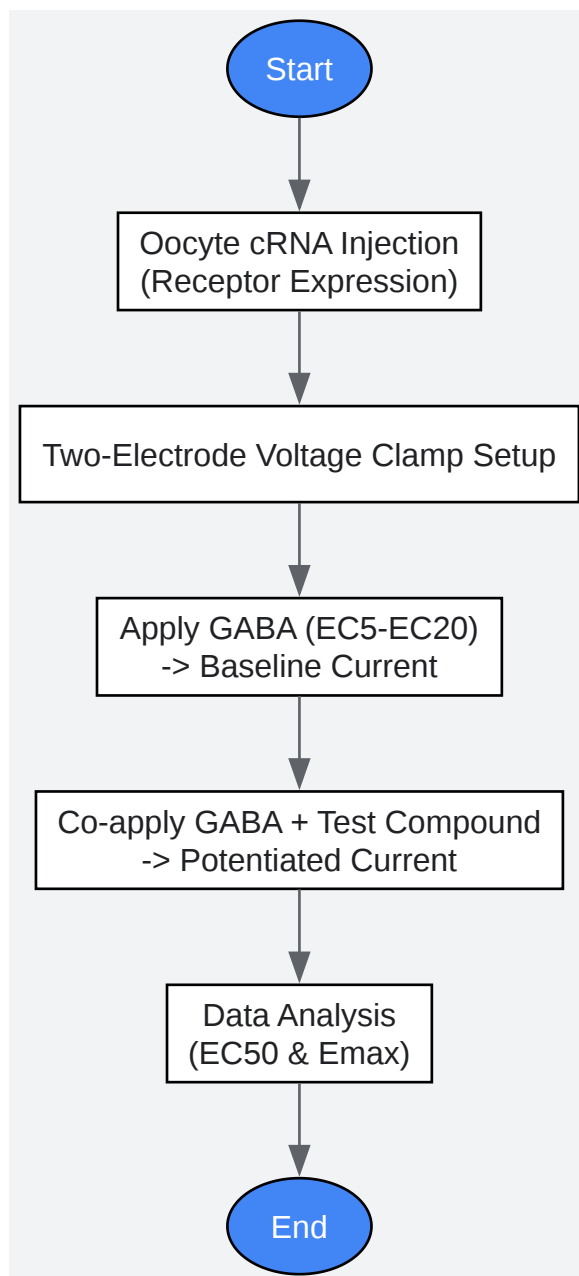

[Click to download full resolution via product page](#)

Caption: Workflow for a two-electrode voltage clamp experiment.

Conclusion

MRK-898 and Zolpidem represent two distinct approaches to modulating GABA_A receptors. Zolpidem's α 1-subunit selectivity underpins its potent sedative-hypnotic effects. In contrast, **MRK-898**, with its broader high-affinity binding profile but functional selectivity for α 2/ α 3 subunits, exemplifies a strategy to achieve anxiolysis while minimizing sedation. The detailed

comparison of their subunit selectivity, supported by the outlined experimental methodologies, provides a valuable framework for researchers in the field of neuroscience and drug discovery. Further elucidation of the functional efficacy of **MRK-898** at the molecular level will be instrumental in validating its potential as a non-sedating anxiolytic.

Need Custom Synthesis?

BenchChem offers custom synthesis for rare earth carbides and specific isotopic labeling.

Email: info@benchchem.com or [Request Quote Online](#).

References

- [1. MRK-898 | GABA Receptor | 461450-30-6 | Invivochem \[invivochem.com\]](#)
- [2. Frontiers | The Z-Drugs Zolpidem, Zaleplon, and Eszopiclone Have Varying Actions on Human GABAA Receptors Containing \$\gamma\$ 1, \$\gamma\$ 2, and \$\gamma\$ 3 Subunits \[frontiersin.org\]](#)
- [3. The Z-Drugs Zolpidem, Zaleplon, and Eszopiclone Have Varying Actions on Human GABAA Receptors Containing \$\gamma\$ 1, \$\gamma\$ 2, and \$\gamma\$ 3 Subunits - PMC \[pmc.ncbi.nlm.nih.gov\]](#)
- [4. Modulation of mammalian dendritic GABAA receptor function by the kinetics of \$\text{Cl}^-\$ and \$\text{HCO}_3^-\$ transport - PMC \[pmc.ncbi.nlm.nih.gov\]](#)
- [5. medchemexpress.com \[medchemexpress.com\]](#)
- [6. GABAA receptor subtype-selective modulators. I. \$\alpha\$ 2/ \$\alpha\$ 3-selective agonists as non-sedating anxiolytics - PubMed \[pubmed.ncbi.nlm.nih.gov\]](#)
- [7. GABAA Receptor Subunit Composition and Functional Properties of \$\text{Cl}^-\$ Channels with Differential Sensitivity to Zolpidem in Embryonic Rat Hippocampal Cells - PMC \[pmc.ncbi.nlm.nih.gov\]](#)
- [8. GABA\(A\) receptor alpha-1 subunit deletion alters receptor subtype assembly, pharmacological and behavioral responses to benzodiazepines and zolpidem - PubMed \[pubmed.ncbi.nlm.nih.gov\]](#)
- [9. researchgate.net \[researchgate.net\]](#)
- [10. benchchem.com \[benchchem.com\]](#)
- [11. giffordbioscience.com \[giffordbioscience.com\]](#)
- [12. Characterization of GABA Receptors - PMC \[pmc.ncbi.nlm.nih.gov\]](#)
- [13. reactionbiology.com \[reactionbiology.com\]](#)

- [14. biophys.uni-frankfurt.de \[biophys.uni-frankfurt.de\]](https://www.biophys.uni-frankfurt.de)
- [15. What is the two electrode voltage-clamp \(TEVC\) method? \[moleculardevices.com\]](https://www.moleculardevices.com)
- To cite this document: BenchChem. [A Comparative Analysis of GABAA Receptor Subunit Selectivity: MRK-898 vs. Zolpidem]. BenchChem, [2026]. [Online PDF]. Available at: [\[https://www.benchchem.com/product/b15616046/docs#a-comparative-analysis-of-gabaa-receptor-subunit-selectivity-mrk-898-vs-zolpidem\]](https://www.benchchem.com/product/b15616046/docs#a-comparative-analysis-of-gabaa-receptor-subunit-selectivity-mrk-898-vs-zolpidem)

Disclaimer & Data Validity:

The information provided in this document is for Research Use Only (RUO) and is strictly not intended for diagnostic or therapeutic procedures. While BenchChem strives to provide accurate protocols, we make no warranties, express or implied, regarding the fitness of this product for every specific experimental setup.

Technical Support: The protocols provided are for reference purposes. Unsure if this reagent suits your experiment?

Need Industrial/Bulk Grade? [Request Custom Synthesis Quote](#)

BenchChem

Our mission is to be the trusted global source of essential and advanced chemicals, empowering scientists and researchers to drive progress in science and industry.

Contact

Address: 3281 E Guasti Rd
Ontario, CA 91761, United States
Phone: (601) 213-4426
Email: info@benchchem.com

[Contact our Ph.D. Support Team for a compatibility check](#)