

# Validating the therapeutic effects of CS12192 in different models

**Author:** BenchChem Technical Support Team. **Date:** April 2026

## Compound of Interest

Compound Name: CS12192  
CAS No.: 1888318-68-0  
Cat. No.: B15615417

[Get Quote](#)

## CS12192: A Novel Inhibitor in Autoimmune Disease Therapy

A Comparative Analysis of the Therapeutic Effects of **CS12192** in Preclinical Models

**CS12192** is an orally administered, selective inhibitor of Janus kinase 3 (JAK3), Janus kinase 1 (JAK1), and TANK-binding kinase 1 (TBK1), currently under development by Shenzhen Chipscreen Biosciences.[1] Preclinical studies have demonstrated its potential as a therapeutic agent for a range of autoimmune diseases, including rheumatoid arthritis, psoriasis, systemic lupus erythematosus, atopic dermatitis, and alopecia areata. This guide provides a comprehensive comparison of the therapeutic effects of **CS12192** in various animal models, presenting supporting experimental data, detailed methodologies, and visualizations of the underlying signaling pathways and experimental workflows.

## Mechanism of Action: Targeting Key Inflammatory Pathways

**CS12192** exerts its therapeutic effects by modulating the JAK-STAT and TBK1 signaling pathways, which are crucial in the pathogenesis of many autoimmune diseases. The JAK-STAT pathway is a primary route for cytokine signaling, and its dysregulation is a hallmark of autoimmune disorders.[2][3][4][5][6] TBK1 is a key kinase in the induction of interferon signaling, which can lead to excessive tissue damage during inflammation.[7] By selectively inhibiting JAK1, JAK3, and TBK1, **CS12192** can effectively suppress the inflammatory cascade. [7][8][9][10]

Below is a diagram illustrating the signaling pathways targeted by **CS12192**.

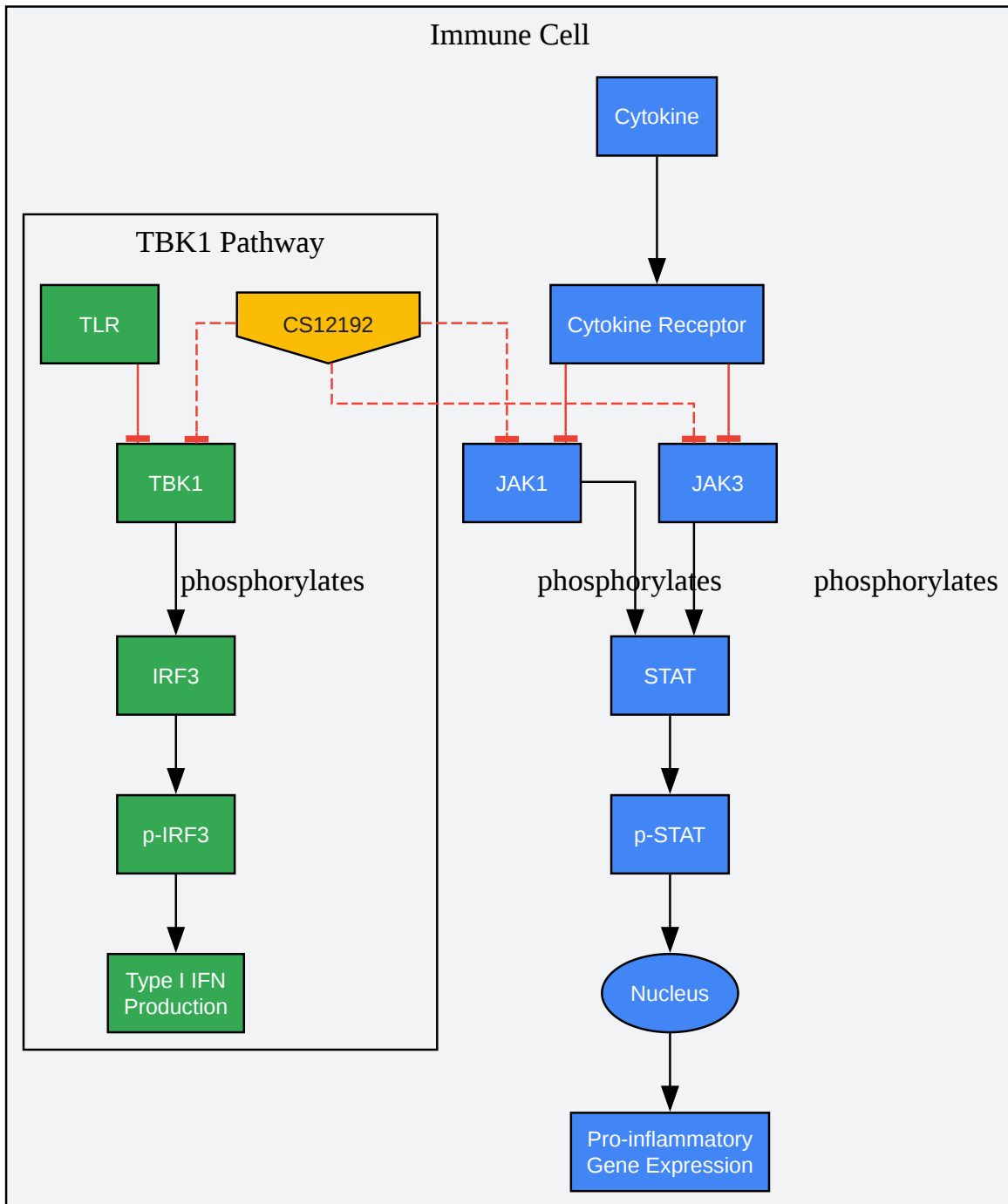

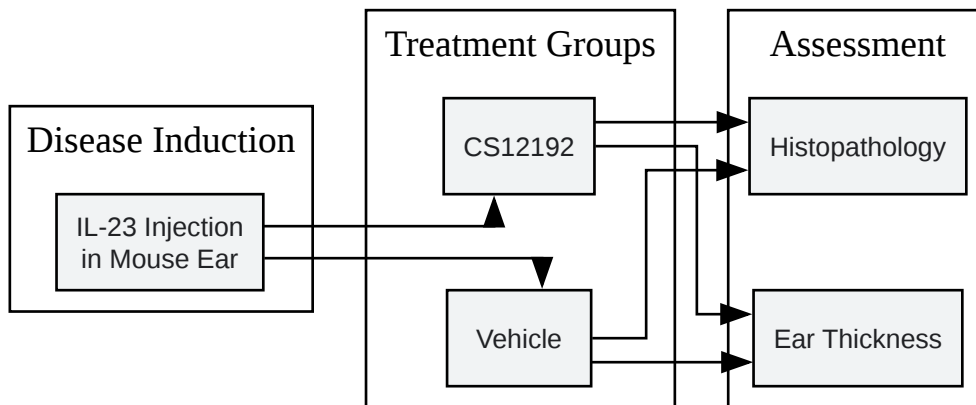
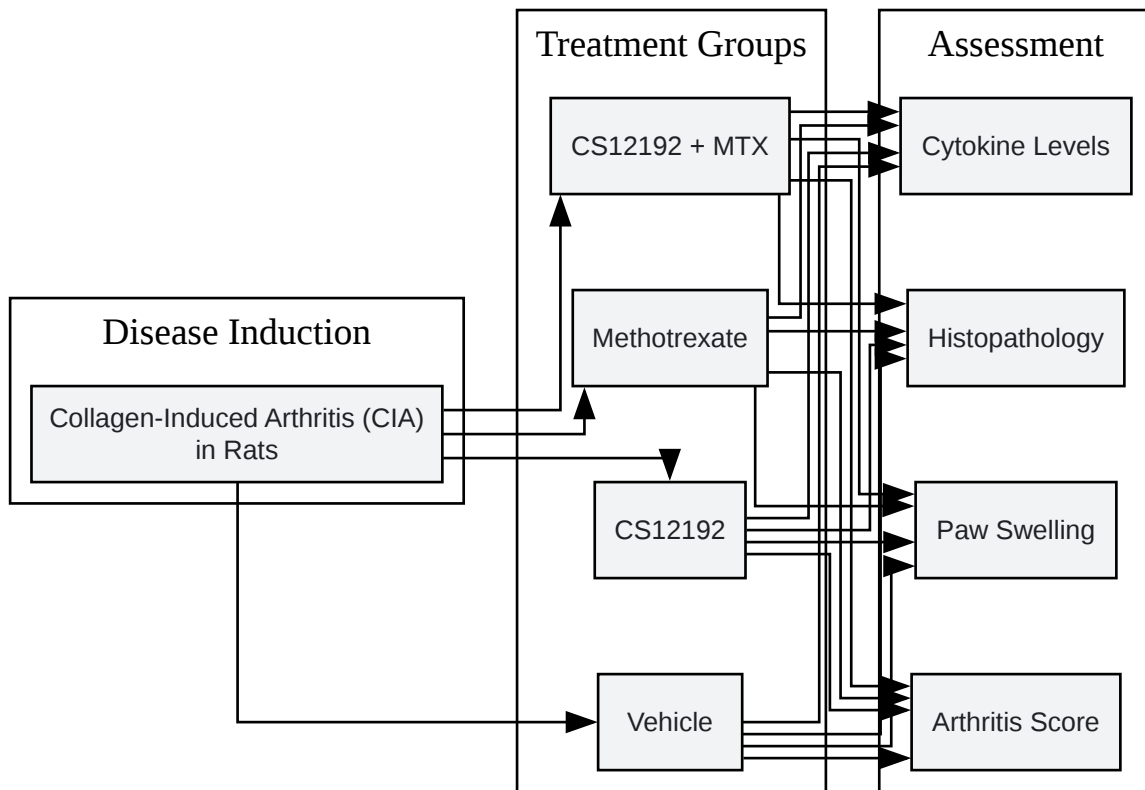

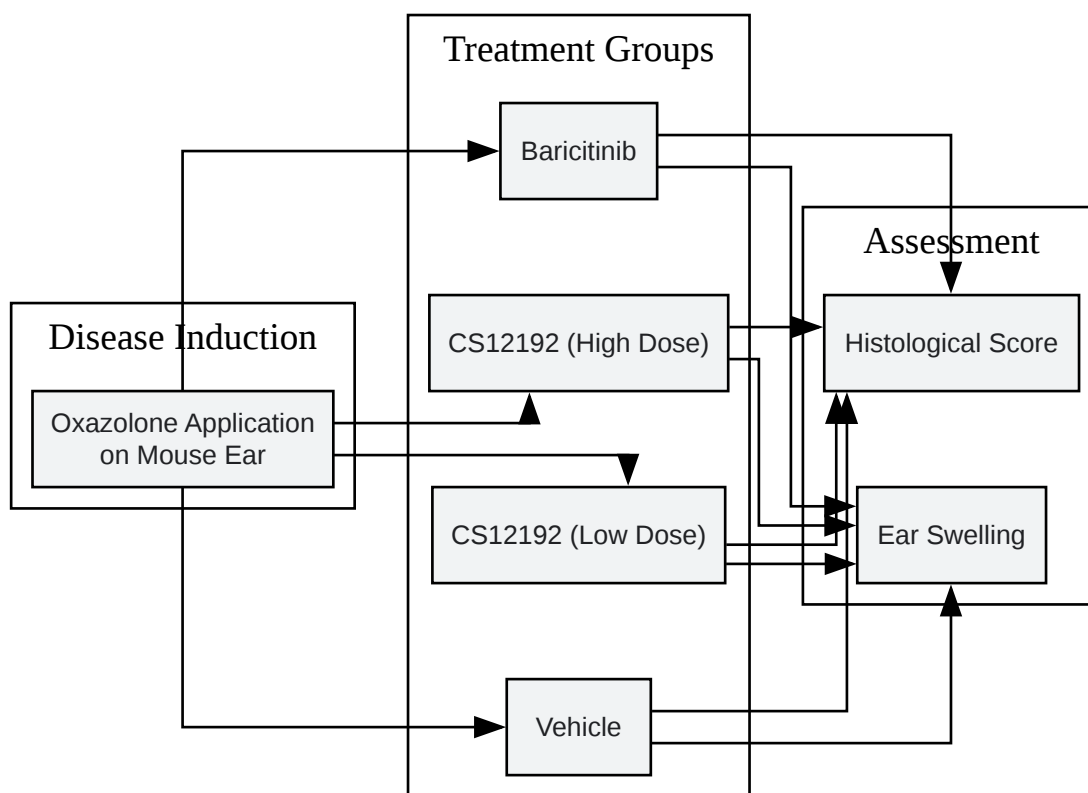

[Click to download full resolution via product page](#)

### Need Custom Synthesis?

BenchChem offers custom synthesis for rare earth carbides and specific isotopic labeling.

Email: [info@benchchem.com](mailto:info@benchchem.com) or [Request Quote Online](#).

## References

- 1. CS-12192 by Shenzhen Chipscreen Biosciences for Graft Versus Host Disease (GVHD): Likelihood of Approval [pharmaceutical-technology.com]
- 2. Janus Kinases and Autoimmunity: Bridging Pathways to Therapy [sciltp.com]
- 3. JAK–STAT Signaling as a Target for Inflammatory and Autoimmune Diseases: Current and Future Prospects - PMC [pmc.ncbi.nlm.nih.gov]
- 4. Frontiers | JAK/STAT pathway: Extracellular signals, diseases, immunity, and therapeutic regimens [frontiersin.org]
- 5. JAK-STAT signaling pathway - Wikipedia [en.wikipedia.org]

- [6. JAK-STAT Signaling as a Target for Inflammatory and Autoimmune Diseases: Current and Future Prospects - PubMed \[pubmed.ncbi.nlm.nih.gov\]](#)
- [7. CS12192, a Novel JAK3/JAK1/TBK1 Inhibitor, Synergistically Enhances the Anti-Inflammation Effect of Methotrexate in a Rat Model of Rheumatoid Arthritis \[mdpi.com\]](#)
- [8. Therapeutic treatment of a novel selective JAK3/JAK1/TBK1 inhibitor, CS12192, in rat and mouse models of rheumatoid arthritis - PubMed \[pubmed.ncbi.nlm.nih.gov\]](#)
- [9. researchgate.net \[researchgate.net\]](#)
- [10. CS12192, a novel JAK3/JAK1/TBK1 inhibitor, attenuates autoimmune dermatoses in murine models - PubMed \[pubmed.ncbi.nlm.nih.gov\]](#)
- To cite this document: BenchChem. [Validating the therapeutic effects of CS12192 in different models]. BenchChem, [2026]. [Online PDF]. Available at: [\[https://www.benchchem.com/product/b15615417/docs#validating-the-therapeutic-effects-of-cs12192-in-different-models\]](https://www.benchchem.com/product/b15615417/docs#validating-the-therapeutic-effects-of-cs12192-in-different-models)

---

#### Disclaimer & Data Validity:

The information provided in this document is for Research Use Only (RUO) and is strictly not intended for diagnostic or therapeutic procedures. While BenchChem strives to provide accurate protocols, we make no warranties, express or implied, regarding the fitness of this product for every specific experimental setup.

**Technical Support:** The protocols provided are for reference purposes. Unsure if this reagent suits your experiment?

**Need Industrial/Bulk Grade?** [Request Custom Synthesis Quote](#)

## BenchChem

Our mission is to be the trusted global source of essential and advanced chemicals, empowering scientists and researchers to drive progress in science and industry.

#### Contact

Address: 3281 E Guasti Rd  
Ontario, CA 91761, United States  
Phone: (601) 213-4426  
Email: [info@benchchem.com](mailto:info@benchchem.com)

Contact our Ph.D. Support Team for a compatibility check