

Technical Support Center: Pep2-8 In Vitro Efficacy

Author: BenchChem Technical Support Team. **Date:** April 2026

Compound of Interest

Compound Name: *Pep2-8*
Cat. No.: *B15615484*

[Get Quote](#)

This technical support guide is designed for researchers, scientists, and drug development professionals who are using the **Pep2-8** peptide in vitro and encountering issues with low efficacy. This resource provides troubleshooting guides and frequently asked questions (FAQs) in a question-and-answer format to directly address specific challenges you may face during your experiments.

Frequently Asked Questions (FAQs) & Troubleshooting Guide

Q1: My **Pep2-8** is showing lower than expected or no activity in my cell-based assay. What are the potential primary causes?

A1: Low efficacy of **Pep2-8** in vitro can stem from several factors, broadly categorized into issues with the peptide itself, the experimental setup, and the assay conditions. Here's a checklist of potential culprits:

- Peptide Integrity and Handling:

- **Improper Storage:** **Pep2-8**, like most peptides, is sensitive to degradation. Ensure it has been stored lyophilized at -20°C or below, protected from light and moisture.[1] Once reconstituted, it should be aliquoted and stored at -80°C to avoid repeated freeze-thaw cycles.
- **Incorrect Reconstitution:** The solubility of **Pep2-8** can be influenced by the solvent. While it is generally water-soluble, using a small amount of a solvent like DMSO before dilution in aqueous buffer can aid dissolution.[1] Ensure the peptide is fully dissolved before use.
- **Peptide Aggregation:** Peptides can self-associate and form aggregates, which are often inactive.[2] This can be influenced by concentration, pH, and buffer composition. Visual inspection for precipitates and dynamic light scattering (DLS) can help assess aggregation.
- **Oxidation:** Although **Pep2-8** does not contain highly susceptible residues like cysteine or methionine, prolonged exposure to air can still lead to oxidation of other residues, potentially affecting its activity.
- **Experimental Design and Assay Conditions:**
 - **Suboptimal Concentration:** The effective concentration of **Pep2-8** is assay-dependent. While it has an IC50 of approximately 0.8 μM for inhibiting PCSK9-LDLR binding in a biochemical assay, higher concentrations (e.g., 50 μM) may be required in cell-based assays to see a significant restoration of LDL uptake.[3][4]
 - **Incubation Time:** The pre-incubation time of **Pep2-8** with PCSK9 and the subsequent incubation with cells are critical. A pre-incubation of at least 30 minutes is recommended to allow for binding, followed by a cellular incubation of several hours (e.g., 4 hours) to observe an effect on LDL receptor levels.[3]
 - **Serum Interference:** Components in serum can degrade peptides or interfere with their binding to the target. It is crucial to consider the stability of **Pep2-8** in the presence of serum.[5][6] Assays can be performed in serum-free or low-serum media, or with lipoprotein-deficient serum, to mitigate these effects.[7]
 - **Cell Health and Passage Number:** The responsiveness of cells can vary with their passage number and overall health. Ensure your cells (e.g., HepG2) are healthy, within a

low passage number range, and seeded at an appropriate density.

Q2: I'm observing high variability between my experimental replicates. What could be causing this?

A2: High variability in in vitro assays can be frustrating. Here are some common sources of inconsistency:

- **Pipetting Errors:** Inaccurate or inconsistent pipetting, especially of small volumes of concentrated peptide or protein solutions, can lead to significant variations in final concentrations.
- **Incomplete Mixing:** Ensure all components (peptide, PCSK9, media) are thoroughly mixed before adding to the cells.
- **Well-to-Well Variation in Cell Seeding:** Uneven cell distribution in multi-well plates will result in different cell numbers per well, affecting the final readout.
- **Edge Effects:** In 96-well plates, the outer wells are more prone to evaporation, which can concentrate reagents and affect cell viability. It is good practice to fill the outer wells with sterile PBS or media and not use them for experimental samples.
- **Reagent Inconsistency:** Ensure that the recombinant PCSK9 and LDLR proteins used are of high quality and have consistent activity across different batches.[2]

Q3: My biochemical assay (e.g., ELISA) shows good inhibition, but my cell-based assay does not. Why the discrepancy?

A3: A disconnect between biochemical and cell-based assay results is a common challenge in drug discovery.[2] Several factors can contribute to this:

- **Cell Permeability:** While **Pep2-8** acts on the extracellular protein PCSK9 and does not need to enter the cell to exert its primary effect, issues with local concentration at the cell surface could play a role.
- **Cellular Metabolism and Efflux:** In a cellular environment, peptides can be metabolized by cell surface or secreted proteases.[2]

- **Presence of Endogenous Factors:** The cellular environment is more complex than a purified biochemical system. Other cellular proteins or components of the extracellular matrix might interact with **Pep2-8** or PCSK9, affecting their interaction.
- **Off-Target Effects:** In a cellular context, the peptide might have off-target interactions that are not present in a purified system.[2] While **Pep2-8** is reported to be specific for PCSK9 and does not bind to other proprotein convertases, high concentrations could potentially lead to unforeseen interactions.[4]

Quantitative Data Summary

The following table summarizes key quantitative parameters for **Pep2-8** activity from published literature. These values can serve as a benchmark for your own experiments.

Parameter	Value	Assay Type	Cell Line (if applicable)	Reference
Binding Affinity (KD)	0.7 μ M	Not specified	N/A	[1][4]
IC50 (PCSK9-LDLR Binding)	0.8 μ M	ELISA	N/A	[4][7]
IC50 (PCSK9-EGF(A) Binding)	0.4 μ M	ELISA	N/A	[4]
Effective Concentration	\sim 50 μ M	LDL Uptake Assay	HepG2	[1][3]

Experimental Protocols

Protocol 1: PCSK9-LDLR Binding Inhibition Assay (ELISA-based)

This protocol is a standard method to assess the ability of **Pep2-8** to inhibit the interaction between PCSK9 and the LDL receptor in a biochemical setting.[2]

- **Plate Coating:** Coat a 96-well high-binding microplate with 1-2 μ g/mL of recombinant human LDLR protein in PBS overnight at 4°C.

- Washing: Wash the plate three times with wash buffer (PBS with 0.05% Tween-20).
- Blocking: Block non-specific binding sites by adding 200 μ L of blocking buffer (e.g., 3% BSA in PBS) to each well and incubate for 1-2 hours at room temperature.
- Washing: Repeat the washing step.
- Peptide Incubation: Prepare serial dilutions of **Pep2-8** and a control peptide in assay buffer. Add the peptide solutions to the wells.
- PCSK9 Addition: Add a constant concentration of biotinylated recombinant human PCSK9 (e.g., 0.5-1 μ g/mL) to all wells (except for the blank) and incubate for 1-2 hours at room temperature to allow for binding.
- Washing: Repeat the washing step.
- Detection: Add streptavidin-HRP conjugate and incubate for 1 hour at room temperature.
- Washing: Repeat the washing step.
- Substrate Addition: Add TMB substrate and incubate in the dark until a blue color develops.
- Stop Reaction: Stop the reaction by adding a stop solution (e.g., 1 M H₂SO₄).
- Readout: Measure the absorbance at 450 nm using a microplate reader. The signal will be inversely proportional to the inhibitory activity of **Pep2-8**.

Protocol 2: Cellular LDL Uptake Assay (HepG2 cells)

This cell-based assay measures the functional effect of **Pep2-8** on restoring LDL uptake in the presence of PCSK9.^{[3][8]}

- Cell Seeding: Seed HepG2 cells in a 96-well plate at a density that will result in approximately 80% confluency on the day of the assay.
- Lipoprotein Starvation: The following day, replace the growth medium with a medium containing lipoprotein-deficient serum (LPDS) and incubate for 18-24 hours to upregulate LDL receptor expression.

- Treatment: Pre-incubate varying concentrations of **Pep2-8** with a fixed concentration of recombinant human PCSK9 (e.g., 10 µg/mL) in the starvation medium for 30 minutes at 37°C.
- Cellular Incubation: Remove the starvation medium from the cells and add the **Pep2-8**/PCSK9 mixture. Incubate for 4 hours at 37°C.
- Labeled LDL Addition: Add fluorescently labeled LDL (e.g., DiI-LDL or BODIPY-LDL) to each well and incubate for an additional 2-4 hours at 37°C.
- Washing: Aspirate the medium and wash the cells three times with cold PBS to remove unbound labeled LDL.
- Readout: Measure the fluorescence intensity using a fluorescence plate reader, fluorescence microscope, or flow cytometer. An increase in fluorescence indicates restored LDL uptake.

Visualizations

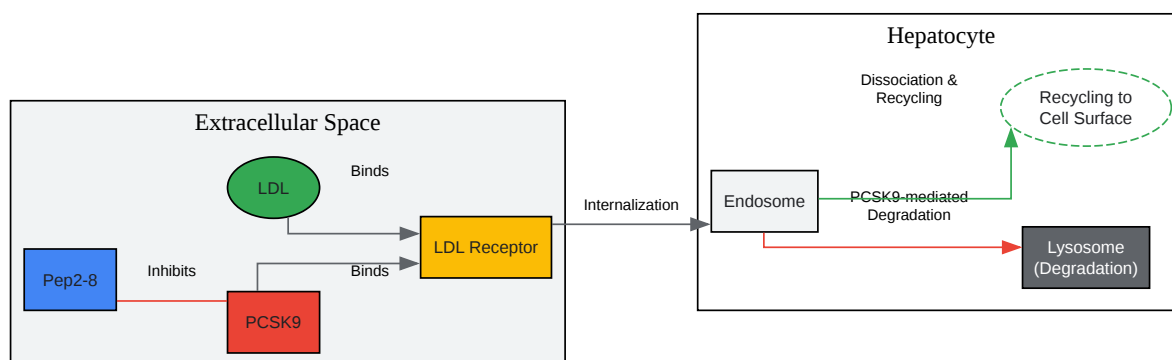

[Click to download full resolution via product page](#)

Caption: PCSK9 signaling pathway and the inhibitory action of **Pep2-8**.

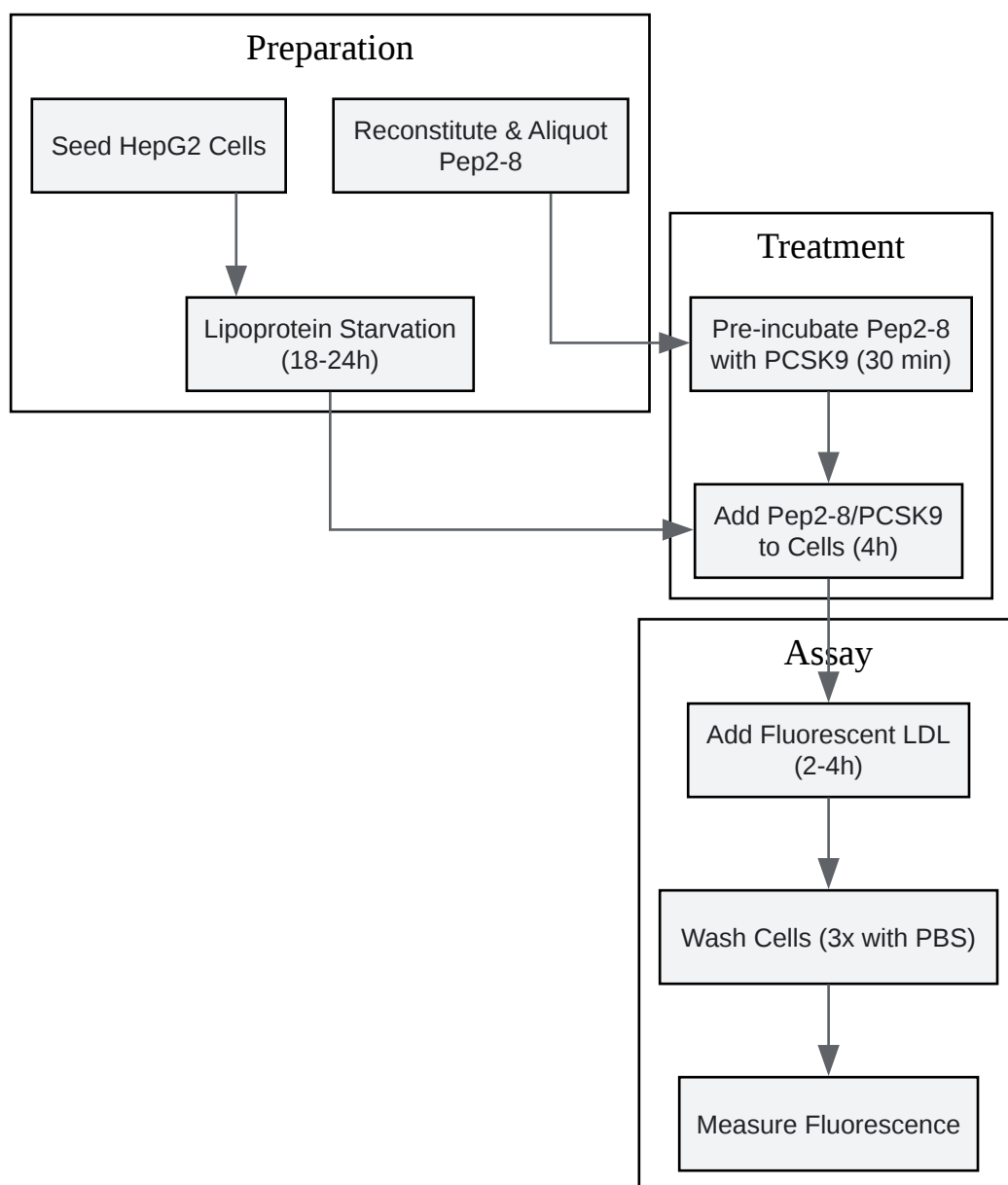

[Click to download full resolution via product page](#)

Caption: Experimental workflow for a cell-based LDL uptake assay with **Pep2-8**.

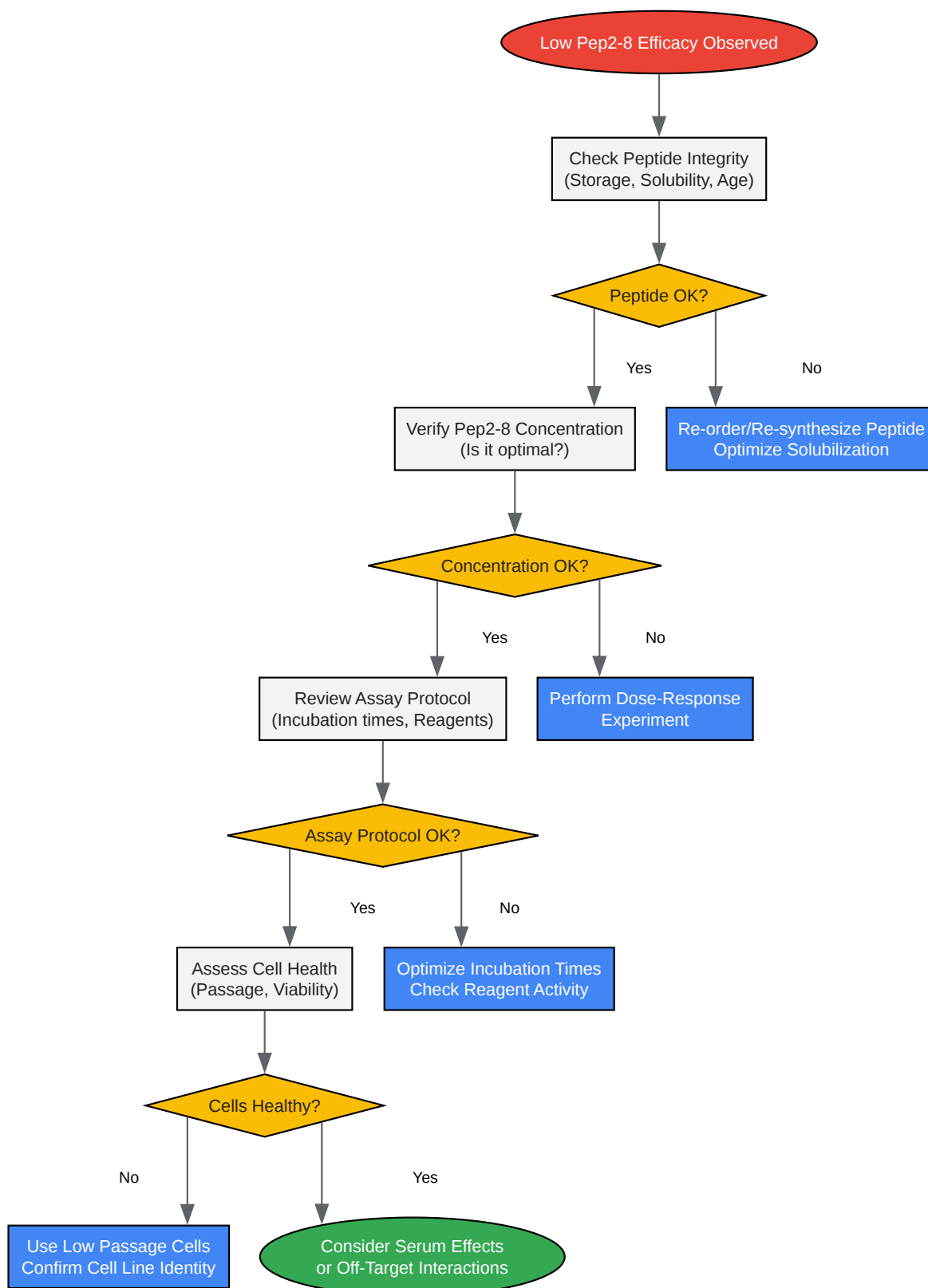

[Click to download full resolution via product page](#)

Caption: Troubleshooting decision tree for low in vitro efficacy of **Pep2-8**.

Need Custom Synthesis?

BenchChem offers custom synthesis for rare earth carbides and specific isotopic labeling.

Email: info@benchchem.com or [Request Quote Online](#).

References

- [1. medchemexpress.com \[medchemexpress.com\]](https://www.medchemexpress.com)
- [2. benchchem.com \[benchchem.com\]](https://www.benchchem.com)
- [3. Identification of a Small Peptide That Inhibits PCSK9 Protein Binding to the Low Density Lipoprotein Receptor - PMC \[pmc.ncbi.nlm.nih.gov\]](https://pubmed.ncbi.nlm.nih.gov/31111111/)
- [4. Identification of a small peptide that inhibits PCSK9 protein binding to the low density lipoprotein receptor - PubMed \[pubmed.ncbi.nlm.nih.gov\]](https://pubmed.ncbi.nlm.nih.gov/31111111/)
- [5. pubs.acs.org \[pubs.acs.org\]](https://pubs.acs.org)
- [6. Differential stability of therapeutic peptides with different proteolytic cleavage sites in blood, plasma and serum | PLOS One \[journals.plos.org\]](https://doi.org/10.1371/journal.pone.0171111)
- [7. cdn.caymanchem.com \[cdn.caymanchem.com\]](https://www.cdn.caymanchem.com)
- [8. LDL Cholesterol Uptake Assay Using Live Cell Imaging Analysis with Cell Health Monitoring - PMC \[pmc.ncbi.nlm.nih.gov\]](https://pubmed.ncbi.nlm.nih.gov/31111111/)
- To cite this document: BenchChem. [Technical Support Center: Pep2-8 In Vitro Efficacy]. BenchChem, [2026]. [Online PDF]. Available at: [\[https://www.benchchem.com/product/b15615484/docs#technical-support-center-pep2-8-in-vitro-efficacy\]](https://www.benchchem.com/product/b15615484/docs#technical-support-center-pep2-8-in-vitro-efficacy)

Disclaimer & Data Validity:

The information provided in this document is for Research Use Only (RUO) and is strictly not intended for diagnostic or therapeutic procedures. While BenchChem strives to provide accurate protocols, we make no warranties, express or implied, regarding the fitness of this product for every specific experimental setup.

Technical Support: The protocols provided are for reference purposes. Unsure if this reagent suits your experiment?

Need Industrial/Bulk Grade? [Request Custom Synthesis Quote](#)

BenchChem

Our mission is to be the trusted global source of essential and advanced chemicals, empowering scientists and researchers to drive progress in science and industry.

Contact

Address: 3281 E Guasti Rd
Ontario, CA 91761, United States
Phone: (601) 213-4426
Email: info@benchchem.com

[Contact our Ph.D. Support Team for a compatibility check](#)