

Technical Support Center: C18 LPA Experiments

Author: BenchChem Technical Support Team. **Date:** April 2026

Compound of Interest

Compound Name: C18 LPA
Cat. No.: B15615134

[Get Quote](#)

Welcome to the technical support center for C18 Lysophosphatidic Acid (LPA) experiments. This resource provides troubleshooting guidance and frequently asked questions (FAQs) to help researchers, scientists, and drug development professionals overcome common challenges encountered during LPA analysis using C18 reverse-phase chromatography.

Frequently Asked Questions (FAQs)

Q1: Why are my measured LPA concentrations artificially high?

A1: Artificially elevated LPA concentrations are a common issue, often stemming from several sources during sample preparation and analysis. A primary cause is the co-elution of more abundant lysophospholipids, such as lysophosphatidylcholine (LPC) and lysophosphatidylserine (LPS), with LPA species.^{[1][2]} These interfering lipids can undergo in-source fragmentation within the mass spectrometer, generating ions that are indistinguishable from authentic LPA, thus inflating the signal.^{[1][2]} Additionally, sample preparation methods using strong acidic conditions can chemically convert lipids like LPC into LPA.^[1]

Q2: How can I prevent the artificial generation of LPA during sample preparation?

A2: To minimize artificial LPA generation, it is crucial to control sample handling and extraction conditions. After blood collection, LPA concentrations can be altered by enzymatic activity.^[3] It

is recommended to keep whole blood samples at low temperatures and add an autotaxin (ATX) inhibitor to plasma samples to prevent LPA production.[3] For extraction, avoid strongly acidic conditions. While mild acidification can improve the recovery of some LPA species, strong acids can lead to the degradation of LPC to LPA.[1][4] Liquid-liquid extraction with acidified 1-butanol has been shown to improve recovery for a range of LPA species.[4]

Q3: What are the key considerations for chromatographic separation of LPA species?

A3: The most critical aspect of chromatographic separation is resolving LPA from other interfering lysophospholipids, especially LPS, which can be particularly challenging.[1] A C18 reverse-phase column is commonly used for this purpose.[1][2][5] The mobile phase composition is key; a gradient of methanol and an aqueous buffer like ammonium acetate with a small amount of formic acid (e.g., 0.1%) can achieve sufficient separation.[1] The goal is to ensure that by the time LPA elutes, the interfering lysophospholipids have been washed off the column or are baseline-separated.

Q4: I'm observing poor peak shapes (e.g., streaking, splitting) in my chromatogram. What could be the cause?

A4: Poor peak shapes can arise from several factors. Column overload is a frequent cause, which can be addressed by diluting the sample.[5][6] For issues like streaking with basic compounds, adding a small percentage of a weak acid (e.g., 0.1-2.0% formic or acetic acid) to the mobile phase can improve peak shape.[6] Conversely, for acidic compounds, a weak base like triethylamine can be added.[6] Peak splitting can indicate a clogged frit at the top of the column, often caused by unfiltered samples.[7]

Troubleshooting Guides

Problem 1: Inaccurate Quantification and High Variability

This guide addresses issues related to obtaining reliable and reproducible quantitative data for LPA.

Symptom	Potential Cause	Recommended Solution
Artificially High LPA Levels	Co-elution and in-source fragmentation of other lysophospholipids (LPC, LPS, LPI).[1][2]	Optimize chromatographic separation to resolve LPA from interfering species. A C18 column with a methanol/aqueous ammonium acetate gradient containing 0.1% formic acid can be effective.[1]
Chemical conversion of LPC to LPA during sample extraction.[1]	Avoid using strong acids for extraction. Use a method like acidified 1-butanol liquid-liquid extraction.[4]	
High Variability Between Replicates	Post-collection enzymatic production or degradation of LPA.[3]	Keep samples on ice immediately after collection and add an autotaxin (ATX) inhibitor to plasma.[3]
Inconsistent sample handling (e.g., freeze-thaw cycles).[1]	Minimize freeze-thaw cycles. Aliquot samples after the initial processing to avoid repeated thawing of the entire sample.	
Difficulty in Quantification	Lack of authentic standards for all LPA species.[1]	Use a stable isotope-labeled LPA standard as a surrogate calibrant for quantification.[1]
Endogenous LPA in the matrix complicating calibration curve generation.[1]	Employ a standard addition method or use a surrogate matrix for the calibration curve.	

Problem 2: Chromatographic Issues

This section provides solutions for common problems encountered during the HPLC/LC-MS analysis of LPA on a C18 column.

Symptom	Potential Cause	Recommended Solution
Poor Peak Shape (Streaking/Elongation)	Sample overload.[5][6]	Dilute the sample before injection.
Interaction of acidic LPA with the stationary phase.	Add a small amount of a weak acid (e.g., 0.1% formic acid) to the mobile phase.[6]	
Split Peaks	Clogged column inlet frit due to particulates in the sample.[7]	Filter all samples through a 0.45 μm filter before injection. [5] As a last resort, the column can be back-flushed at a low flow rate to dislodge particulates.[7]
High Backpressure	Blockage in the system, often at the column inlet frit or in-line filter.[8]	Systematically check for blockages by disconnecting components, starting from the detector and moving towards the pump.[8] Ensure an appropriate in-line filter is used.[8]
Retention Time Shifts	Changes in mobile phase composition.	Prepare fresh mobile phase daily and ensure proper mixing if using a multi-solvent gradient.
Column degradation.[9]	Use a guard column to protect the analytical column. If retention times consistently decrease, the column may need to be replaced.	
Ghost Peaks	Carryover from a previous injection.	Implement a robust needle wash protocol and inject a blank solvent run after samples with high concentrations.

Experimental Protocols

Protocol 1: LPA Extraction from Plasma (Acidified 1-Butanol Method)

This protocol is designed to maximize the recovery of various LPA species while minimizing artificial generation.

- **Sample Collection:** Collect whole blood in EDTA-containing tubes and immediately place on ice.
- **Plasma Preparation:** Centrifuge the blood at 4°C to separate the plasma. Transfer the plasma to a new tube and add an autotaxin inhibitor.
- **Extraction:**
 - To 100 µL of plasma, add an internal standard (e.g., C17:0-LPA).
 - Add 1 mL of 1-butanol acidified with HCl (to adjust the sample pH).
 - Vortex vigorously for 2 minutes.
 - Centrifuge at 3000 x g for 10 minutes to separate the phases.
- **Drying and Reconstitution:**
 - Transfer the upper organic layer to a new tube.
 - Evaporate the solvent under a stream of nitrogen.
 - Reconstitute the dried extract in the initial mobile phase for LC-MS analysis.

Protocol 2: C18 Reverse-Phase LC-MS/MS for LPA Analysis

This protocol provides a starting point for the chromatographic separation and mass spectrometric detection of LPA.

- Column: C18 reverse-phase column (e.g., 2.1 mm ID x 100 mm, 1.8 μ m particle size).
- Mobile Phase A: Water with 0.1% Formic Acid.
- Mobile Phase B: Acetonitrile with 0.1% Formic Acid.
- Gradient:
 - 0-2 min: 20% B
 - 2-10 min: 20-80% B
 - 10-12 min: 80-95% B
 - 12-15 min: Hold at 95% B
 - 15-16 min: 95-20% B
 - 16-20 min: Re-equilibrate at 20% B
- Flow Rate: 0.3 mL/min
- Column Temperature: 40°C
- Injection Volume: 5 μ L
- Mass Spectrometry:
 - Ionization Mode: Negative Electrospray Ionization (ESI-).
 - Detection: Multiple Reaction Monitoring (MRM).
 - MRM Transitions: Monitor the specific parent-to-daughter ion transitions for each LPA species and the internal standard. For example, for C18:1 LPA, the transition could be m/z 435.3 -> 153.1.

Visualizations

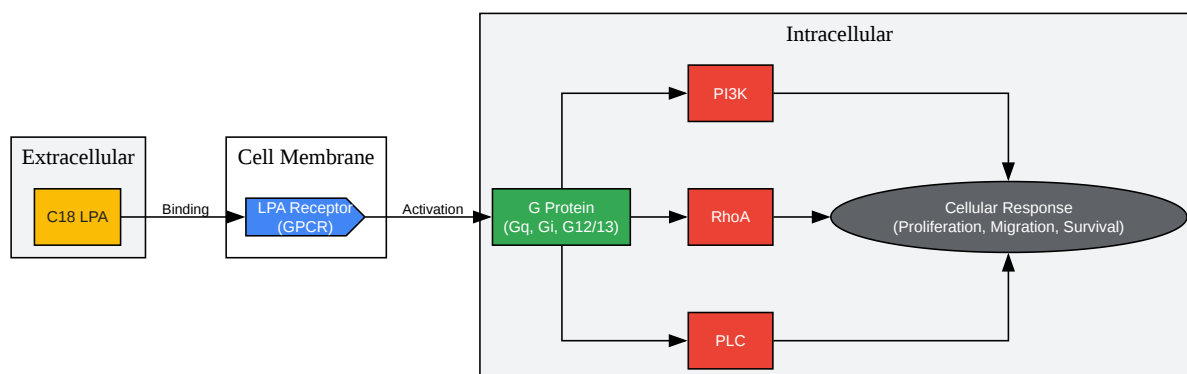

[Click to download full resolution via product page](#)

Caption: **C18 LPA** signaling pathway overview.

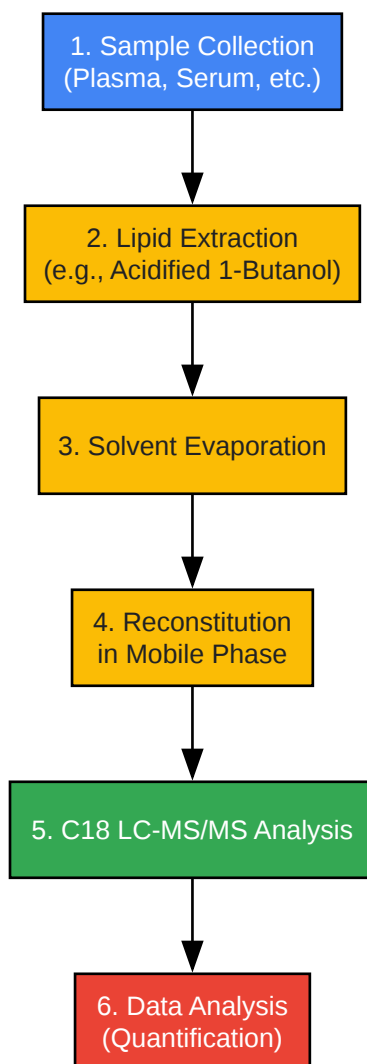

[Click to download full resolution via product page](#)

Caption: General experimental workflow for **C18 LPA** analysis.

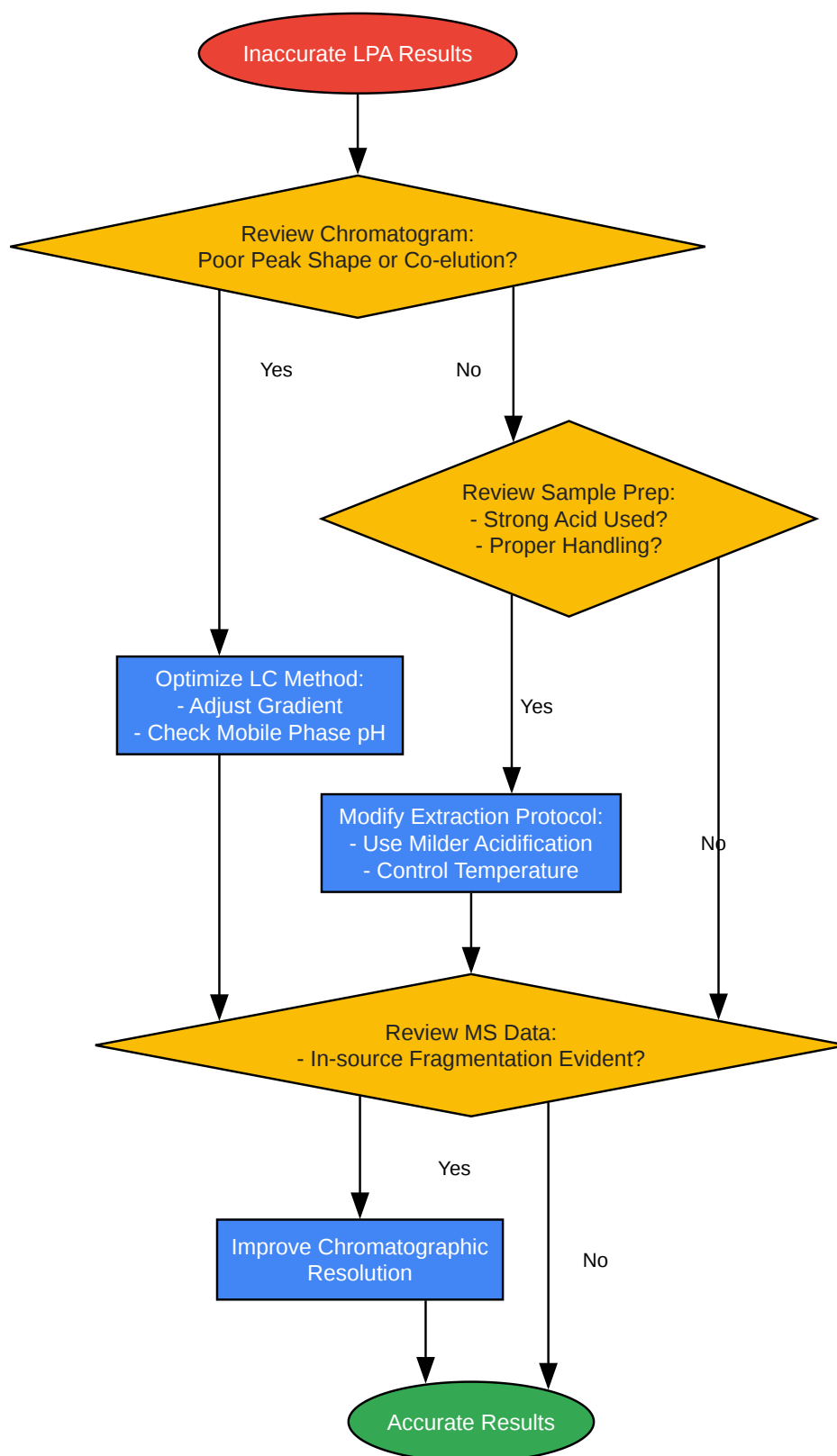

[Click to download full resolution via product page](#)

Caption: Troubleshooting flowchart for inaccurate LPA results.

Need Custom Synthesis?

BenchChem offers custom synthesis for rare earth carbides and specific isotopic labeling.

Email: info@benchchem.com or [Request Quote Online](#).

References

- 1. Challenges in accurate quantitation of lysophosphatidic acids in human biofluids - PMC [[pmc.ncbi.nlm.nih.gov](https://pubmed.ncbi.nlm.nih.gov/)]
- 2. Measurement of endogenous lysophosphatidic acid by ESI-MS/MS in plasma samples requires pre-separation of lysophosphatidylcholine - PMC [[pmc.ncbi.nlm.nih.gov](https://pubmed.ncbi.nlm.nih.gov/)]
- 3. [researchgate.net](https://www.researchgate.net/) [[researchgate.net](https://www.researchgate.net/)]
- 4. Quantitative determination of lysophosphatidic acids (LPAs) in human saliva and gingival crevicular fluid (GCF) by LC-MS/MS - PMC [[pmc.ncbi.nlm.nih.gov](https://pubmed.ncbi.nlm.nih.gov/)]
- 5. [benchchem.com](https://www.benchchem.com/) [[benchchem.com](https://www.benchchem.com/)]
- 6. [silicycle.com](https://www.silicycle.com/) [[silicycle.com](https://www.silicycle.com/)]
- 7. [youtube.com](https://www.youtube.com/) [[youtube.com](https://www.youtube.com/)]
- 8. [agilent.com](https://www.agilent.com/) [[agilent.com](https://www.agilent.com/)]
- 9. m.youtube.com [m.youtube.com]
- To cite this document: BenchChem. [Technical Support Center: C18 LPA Experiments]. BenchChem, [2026]. [Online PDF]. Available at: [<https://www.benchchem.com/product/b15615134/docs#technical-support-center-c18-lpa-experiments>]

Disclaimer & Data Validity:

The information provided in this document is for Research Use Only (RUO) and is strictly not intended for diagnostic or therapeutic procedures. While BenchChem strives to provide accurate protocols, we make no warranties, express or implied, regarding the fitness of this product for every specific experimental setup.

Technical Support: The protocols provided are for reference purposes. Unsure if this reagent suits your experiment?

Need Industrial/Bulk Grade? [Request Custom Synthesis Quote](#)

BenchChem

Our mission is to be the trusted global source of essential and advanced chemicals, empowering scientists and researchers to drive progress in science and industry.

Contact

Address: 3281 E Guasti Rd
Ontario, CA 91761, United States
Phone: (601) 213-4426
Email: info@benchchem.com

[Contact our Ph.D. Support Team for a compatibility check](#)