

# Application Notes and Protocols for Sdh-IN-18 In Vitro Enzyme Assay

**Author:** BenchChem Technical Support Team. **Date:** April 2026

## Compound of Interest

Compound Name: Sdh-IN-18

Cat. No.: B15615788

[Get Quote](#)

For Researchers, Scientists, and Drug Development Professionals

## Introduction

**Sdh-IN-18** is a potent inhibitor of succinate dehydrogenase (SDH), a critical enzyme complex found in the inner mitochondrial membrane.[1] Also known as Complex II of the electron transport chain, SDH plays a dual role in cellular metabolism: it catalyzes the oxidation of succinate to fumarate in the Krebs cycle and participates in oxidative phosphorylation.[2] Inhibition of SDH disrupts these fundamental processes, leading to impaired cellular respiration and energy production. This property makes SDH a significant target for the development of fungicides and potential therapeutic agents. These application notes provide a detailed protocol for conducting an in vitro enzyme assay to characterize the inhibitory activity of **Sdh-IN-18** against SDH.

## Principle of the Assay

The in vitro activity of succinate dehydrogenase can be determined by monitoring the reduction of an artificial electron acceptor, 2,6-dichlorophenolindophenol (DCPIP). In this colorimetric assay, SDH catalyzes the oxidation of its substrate, succinate, to fumarate. The electrons released in this reaction are transferred to DCPIP, causing it to change from a blue (oxidized) to

a colorless (reduced) state. The rate of this color change, measured as a decrease in absorbance at 600 nm, is directly proportional to the SDH enzyme activity. The presence of an inhibitor, such as **Sdh-IN-18**, will decrease the rate of DCPIP reduction, allowing for the quantification of its inhibitory potency.

## Data Presentation

Table 1: Inhibitory Activity of **Sdh-IN-18**

| Compound  | Target Organism/System   | Assay Type          | IC50      | EC50      |
|-----------|--------------------------|---------------------|-----------|-----------|
| Sdh-IN-18 | Fungal                   | Enzyme Inhibition   | 8.70 mg/L | -         |
| Sdh-IN-18 | Rhizoctonia solani       | Antifungal Activity | -         | 0.48 mg/L |
| Sdh-IN-18 | Sclerotinia sclerotiorum | Antifungal Activity | -         | 1.4 mg/L  |

IC50 (Half-maximal inhibitory concentration) is the concentration of an inhibitor required to reduce the activity of an enzyme by 50%.<sup>[1]</sup> EC50 (Half-maximal effective concentration) is the concentration of a drug that gives half-maximal response.<sup>[1]</sup>

Table 2: Comparative Inhibitory Activity of Various SDH Inhibitors

| Inhibitor   | Target Organism/System    | Assay Type          | IC50/EC50    |
|-------------|---------------------------|---------------------|--------------|
| Atpenin A5  | Bovine heart mitochondria | Enzyme Inhibition   | 2.4 ± 1.2 nM |
| Malonate    | Bovine heart mitochondria | Enzyme Inhibition   | 96 ± 1.3 μM  |
| Compound 5i | Sclerotinia sclerotiorum  | Antifungal Activity | 0.73 μg/mL   |
| Compound 5p | Rhizoctonia cerealis      | Antifungal Activity | 6.48 μg/mL   |

## Experimental Protocols

### In Vitro Succinate Dehydrogenase (SDH) Activity Assay (DCPIP Method)

This protocol is adapted from standard procedures for measuring SDH activity and can be used to determine the IC50 of **Sdh-IN-18**.<sup>[1]</sup>

Materials:

- Mitochondrial fraction or purified SDH
- **Sdh-IN-18**
- Assay Buffer: 0.1 M Tris-HCl, pH 8.0
- Sodium Succinate solution (0.6 M)
- Potassium Cyanide (KCN) solution (0.2 M, freshly prepared)
- Phenazine methosulfate (PMS) solution (12.5 mM, freshly prepared)
- 2,6-dichlorophenolindophenol (DCPIP) solution (2.5 mM, freshly prepared)
- Spectrophotometer or microplate reader capable of measuring absorbance at 600 nm

#### Procedure:

- Preparation of Reagents: Prepare all solutions using high-purity water and keep them on ice.
- Reaction Mixture Preparation: In a microplate well or a cuvette, prepare the reaction mixture by adding the following components in the specified order:
  - Assay Buffer
  - KCN solution
  - Sodium Succinate solution
  - Enzyme preparation (mitochondrial fraction or purified SDH)
  - **Sdh-IN-18** at various concentrations (and a vehicle control)
  - Distilled water to the final volume.
- Pre-incubation: Incubate the reaction mixture at 25°C for 10 minutes to allow the inhibitor to interact with the enzyme.
- Reaction Initiation: To start the reaction, add PMS solution followed by DCPIP solution. Mix briefly and gently.
- Measurement: Immediately measure the decrease in absorbance at 600 nm over time (e.g., every 30 seconds for 10 minutes) using a spectrophotometer or microplate reader in kinetic mode.
- Blank Measurement: A blank control should be included, containing all components except the enzyme preparation, to account for non-enzymatic reduction of DCPIP.

#### Data Analysis:

- Calculate the rate of reaction ( $\Delta$ Absorbance/minute) for each concentration of **Sdh-IN-18** and the vehicle control.

- Determine the percentage of inhibition for each **Sdh-IN-18** concentration relative to the vehicle control.
- Plot the percentage of inhibition against the logarithm of the **Sdh-IN-18** concentration.
- Determine the IC50 value by fitting the data to a dose-response curve.

## Visualizations

### Signaling Pathway of Succinate Dehydrogenase and its Inhibition

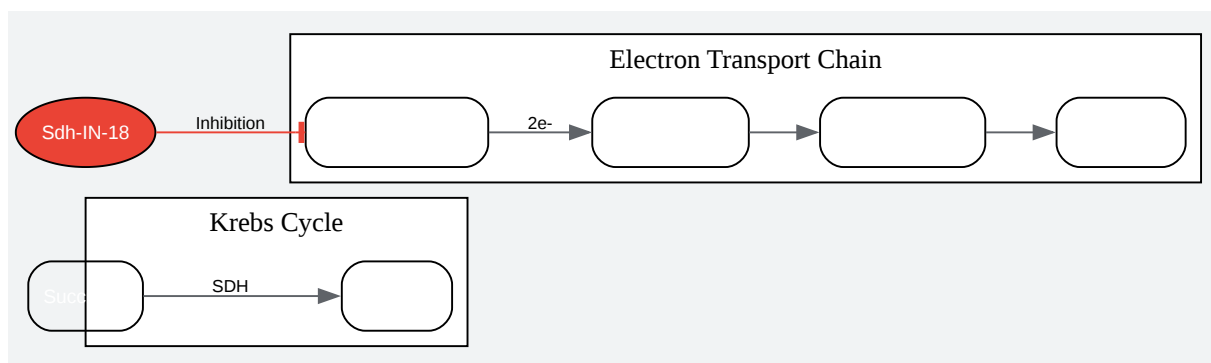

[Click to download full resolution via product page](#)

Caption: Mechanism of SDH inhibition by **Sdh-IN-18**.

### Experimental Workflow for In Vitro SDH Inhibition Assay

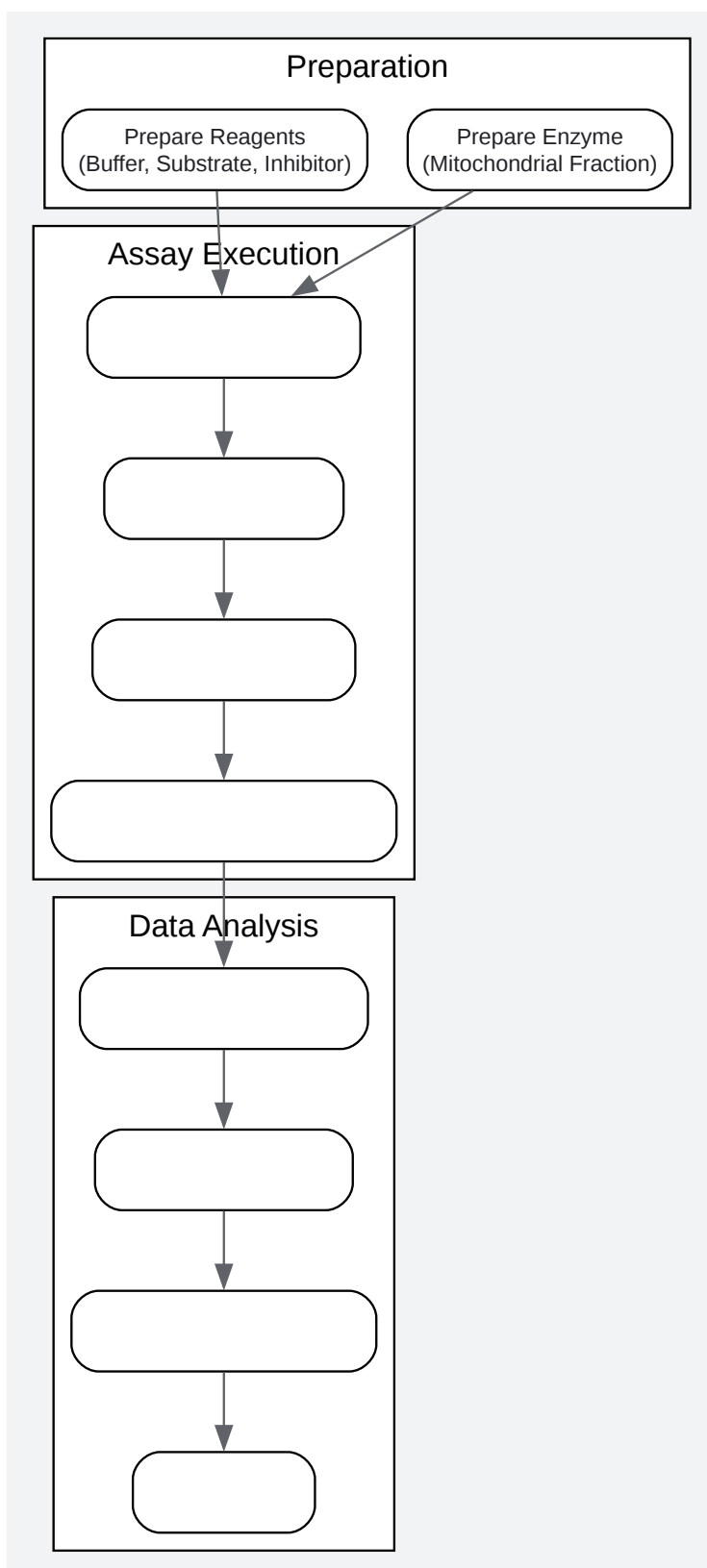

[Click to download full resolution via product page](#)

Caption: Workflow for determining the IC<sub>50</sub> of **Sdh-IN-18**.

### Need Custom Synthesis?

BenchChem offers custom synthesis for rare earth carbides and specific isotopic labeling.

Email: [info@benchchem.com](mailto:info@benchchem.com) or [Request Quote Online](#).

## References

- [1. benchchem.com \[benchchem.com\]](https://www.benchchem.com)
- [2. The assembly of succinate dehydrogenase: a key enzyme in bioenergetics - PMC \[pmc.ncbi.nlm.nih.gov\]](https://pubmed.ncbi.nlm.nih.gov/11111111/)
- To cite this document: BenchChem. [Application Notes and Protocols for Sdh-IN-18 In Vitro Enzyme Assay]. BenchChem, [2026]. [Online PDF]. Available at: [\[https://www.benchchem.com/product/b15615788/docs#application-notes-and-protocols-for-sdh-in-18-in-vitro-enzyme-assay\]](https://www.benchchem.com/product/b15615788/docs#application-notes-and-protocols-for-sdh-in-18-in-vitro-enzyme-assay)

---

### Disclaimer & Data Validity:

The information provided in this document is for Research Use Only (RUO) and is strictly not intended for diagnostic or therapeutic procedures. While BenchChem strives to provide accurate protocols, we make no warranties, express or implied, regarding the fitness of this product for every specific experimental setup.

**Technical Support:** The protocols provided are for reference purposes. Unsure if this reagent suits your experiment?

**Need Industrial/Bulk Grade?** [Request Custom Synthesis Quote](#)

## BenchChem

Our mission is to be the trusted global source of essential and advanced chemicals, empowering scientists and researchers to drive progress in science and industry.

### Contact

Address: 3281 E Guasti Rd  
Ontario, CA 91761, United States  
Phone: (601) 213-4426  
Email: [info@benchchem.com](mailto:info@benchchem.com)

Contact our Ph.D. Support Team for a compatibility check