

# Application Notes and Protocols for CS12192 in Murine Models

**Author:** BenchChem Technical Support Team. **Date:** April 2026

## Compound of Interest

Compound Name: CS12192  
CAS No.: 1888318-68-0  
Cat. No.: B15615417

[Get Quote](#)

## For Researchers, Scientists, and Drug Development Professionals

Introduction:

**CS12192** is a novel small molecule inhibitor targeting Janus kinase 3 (JAK3), Janus kinase 1 (JAK1), and TANK-binding kinase 1 (TBK1).[1][2][3][4][5] Its targeted mechanism of action makes it a compound of significant interest for the treatment of various autoimmune and inflammatory diseases. Preclinical studies in murine models have demonstrated its therapeutic potential in conditions such as rheumatoid arthritis, autoimmune dermatoses, and graft-versus-host disease.[1][2][3][4][5] These application notes provide a detailed overview of the dosage and administration of **CS12192** in various murine models, along with the associated experimental protocols.

## Data Presentation: Dosage and Administration of CS12192

The following tables summarize the quantitative data on the dosage and administration of **CS12192** in different murine models based on available preclinical studies.

Table 1: Dosage of **CS12192** in Murine Models of Autoimmune Dermatoses

Murine Model	Disease	Dosage	Administration Route	Frequency	Reference
IL-23-Induced	Psoriasis	Dose-dependent effects observed	Not explicitly stated	Not explicitly stated	[2]
MRL/MpJ-Fas <sup>lpr</sup> /J (MRL/lpr)	Systemic Lupus Erythematosus (SLE)	Not explicitly stated; ameliorated cutaneous parameters	Not explicitly stated	Not explicitly stated	[2]
Oxazolone (OXA) and Dinitrochlorobenzene (DNCB)-Induced	Atopic Dermatitis (AD)	Dose-dependently improved ear swelling and reduced histological scores	Not explicitly stated	Not explicitly stated	[2]

Table 2: Dosage of **CS12192** in a Murine Model of Rheumatoid Arthritis

Murine Model	Disease	Dosage	Administration Route	Frequency	Reference
Collagen-Induced Arthritis (CIA)	Rheumatoid Arthritis	Dose-dependent amelioration of disease severity	Oral	Not explicitly stated	[3][4]

Table 3: Dosage of **CS12192** in a Murine Model of Graft-versus-Host Disease

Murine Model	Disease	Dosage	Administration Route	Frequency	Reference
Allogeneic Bone Marrow Transplantation	Graft-versus-Host Disease (GVHD)	40 and 80 mg/kg	Not explicitly stated	BID (twice daily)	

## Signaling Pathway of CS12192

**CS12192** exerts its therapeutic effects by inhibiting the JAK/STAT signaling pathway, which is crucial for mediating the signaling of multiple cytokines involved in autoimmune diseases.[1][2] Specifically, it targets JAK1 and JAK3, and also TBK1. This inhibition leads to decreased activation of downstream signaling molecules like STATs and IRF3, ultimately down-regulating the expression of inflammatory genes.[3]

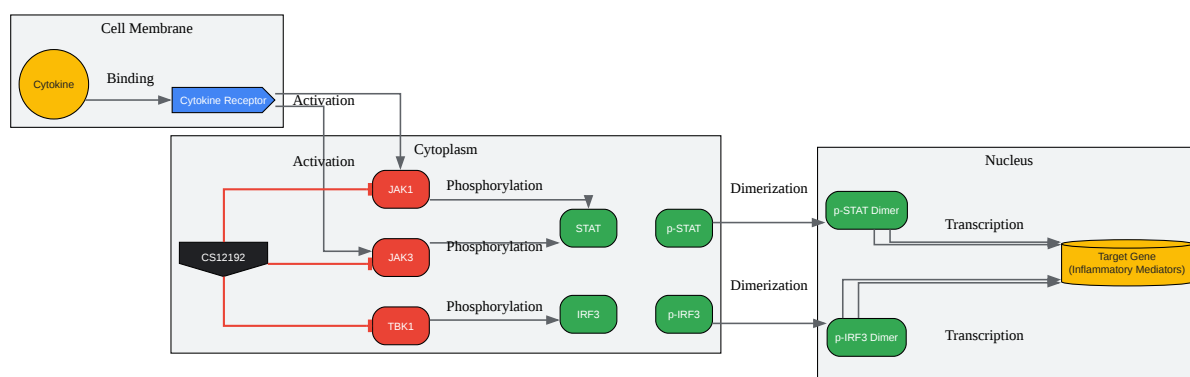

[Click to download full resolution via product page](#)

Caption: **CS12192** inhibits JAK1, JAK3, and TBK1, blocking downstream signaling.

## Experimental Protocols

The following are detailed methodologies for key experiments cited in the evaluation of **CS12192**.

### Murine Model of Psoriasis (IL-23-Induced)

Objective: To induce a psoriasis-like skin inflammation model in mice to evaluate the efficacy of **CS12192**.

Materials:

- Female C57BL/6 mice (8-10 weeks old)
- Recombinant murine IL-23
- Phosphate-buffered saline (PBS)
- **CS12192**, vehicle control
- Calipers for ear thickness measurement

Protocol:

- Acclimatize mice for at least one week before the experiment.
- On day 0, anesthetize the mice and administer an intradermal injection of IL-23 (e.g., 500 ng in 20  $\mu$ L of PBS) into the right ear pinna. The left ear can be injected with PBS as a control.
- Repeat the IL-23 or PBS injections daily for a specified period (e.g., 4-14 days).
- Administer **CS12192** or vehicle control to the mice according to the desired dosage and route (e.g., oral gavage) starting from day 0 until the end of the experiment.
- Monitor the mice daily for signs of inflammation, including ear thickness, redness, and scaling. Measure ear thickness using a digital caliper.
- At the end of the study, euthanize the mice and collect ear tissue for histological analysis (e.g., H&E staining to assess epidermal thickness and inflammatory cell infiltration) and measurement of ear weight.

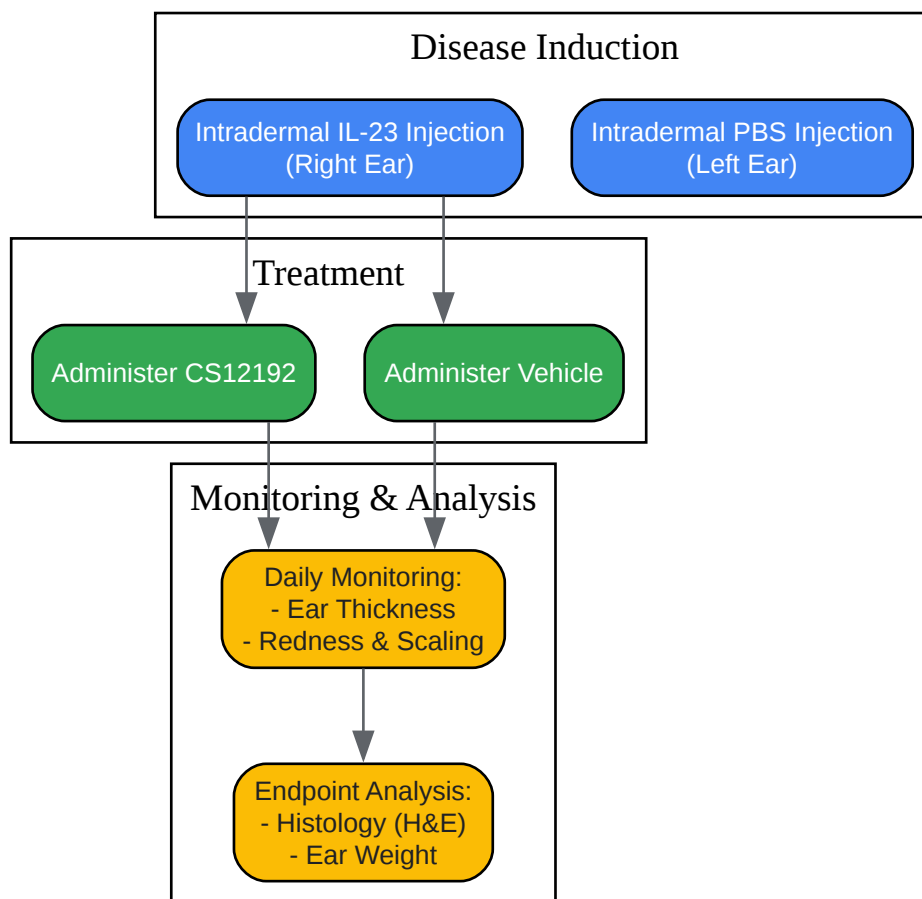

[Click to download full resolution via product page](#)

Caption: Workflow for the IL-23-induced psoriasis mouse model.

## Murine Model of Rheumatoid Arthritis (Collagen-Induced Arthritis - CIA)

Objective: To induce an autoimmune arthritis model in mice that mimics human rheumatoid arthritis to assess the therapeutic effect of **CS12192**.

Materials:

- DBA/1 mice (male, 8-10 weeks old)
- Bovine type II collagen (CII)
- Complete Freund's Adjuvant (CFA)

- Incomplete Freund's Adjuvant (IFA)
- **CS12192**, vehicle control
- Calipers for paw thickness measurement

Protocol:

- Prepare an emulsion of bovine type II collagen (2 mg/mL) in CFA (1:1 ratio).
- On day 0, immunize mice intradermally at the base of the tail with 100  $\mu$ L of the CII/CFA emulsion.
- On day 21, administer a booster injection of 100  $\mu$ L of an emulsion of CII (2 mg/mL) in IFA (1:1 ratio) intradermally at the base of the tail.
- Begin oral administration of **CS12192** or vehicle control at the onset of clinical signs of arthritis (typically around day 21-28) and continue daily for the duration of the study.
- Monitor mice 2-3 times per week for the development and severity of arthritis. Clinical scoring can be based on a scale of 0-4 for each paw (0=normal, 1=mild swelling/erythema, 2=moderate swelling/erythema, 3=severe swelling/erythema of the entire paw, 4=maximal inflammation with joint deformity).
- Measure hind paw thickness using a digital caliper.
- At the end of the study, collect blood for serum cytokine analysis and paws for histological examination of joint inflammation and bone erosion.

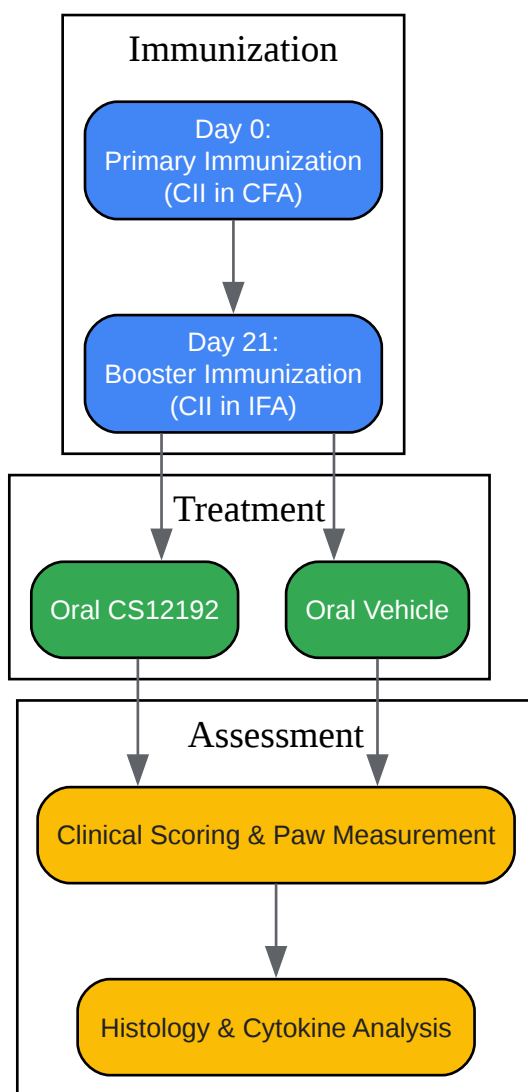

[Click to download full resolution via product page](#)

Caption: Experimental workflow for the collagen-induced arthritis model.

## Murine Model of Systemic Lupus Erythematosus (MRL/lpr Mice)

Objective: To evaluate the therapeutic effect of **CS12192** on the spontaneous development of lupus-like disease in MRL/lpr mice.

Materials:

- Female MRL/MpJ-Faslpr/J (MRL/lpr) mice

- **CS12192**, vehicle control
- Urine test strips for proteinuria
- Equipment for blood collection and analysis (serum dsDNA, BUN)

Protocol:

- Use female MRL/lpr mice, which spontaneously develop a lupus-like autoimmune disease.[6][7][8]
- Begin treatment with **CS12192** or vehicle control at a specified age (e.g., 8-10 weeks) before or after the onset of disease symptoms.
- Monitor mice weekly for body weight and signs of disease, including lymphadenopathy and skin lesions.[2][8]
- Monitor proteinuria weekly using urine test strips as an indicator of kidney damage.
- Collect blood periodically (e.g., every 4 weeks) to measure serum levels of anti-dsDNA antibodies and blood urea nitrogen (BUN) as markers of disease activity and kidney function.
- At the end of the study (e.g., 20-24 weeks of age), euthanize the mice and collect spleens and lymph nodes for weight measurement and kidneys for histopathological analysis of glomerulonephritis.

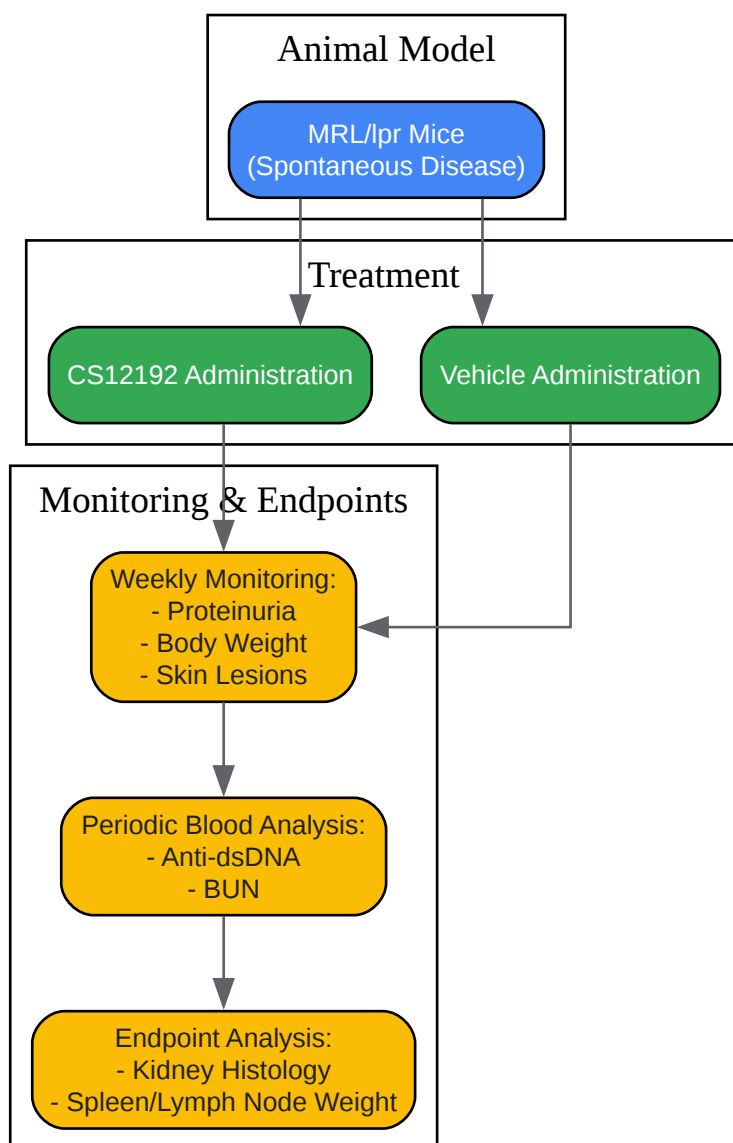

[Click to download full resolution via product page](#)

Caption: Workflow for studying **CS12192** in the MRL/lpr mouse model of SLE.

## Murine Model of Atopic Dermatitis (Oxazolone-Induced)

Objective: To induce an atopic dermatitis-like skin inflammation to assess the efficacy of **CS12192**.

Materials:

- BALB/c or NC/Nga mice

- Oxazolone (4-ethoxymethylene-2-phenyl-2-oxazolin-5-one)
- Acetone and olive oil (vehicle for oxazolone)
- **CS12192**, vehicle control
- Calipers for ear thickness measurement

Protocol:

- On day 0, sensitize the mice by applying a solution of oxazolone (e.g., 1.5% in acetone) to a shaved area on the abdomen.[9]
- After a sensitization period (e.g., 5-7 days), challenge the mice by applying a lower concentration of oxazolone (e.g., 1% in acetone/olive oil) to the right ear.[9]
- Repeat the challenge every other day or as required to induce chronic inflammation.
- Administer **CS12192** or vehicle control topically or systemically according to the study design, starting before or after the challenge phase.
- Measure ear thickness daily or on challenge days using a digital caliper.
- At the end of the experiment, collect ear tissue for histological analysis to assess epidermal hyperplasia and inflammatory cell infiltration.

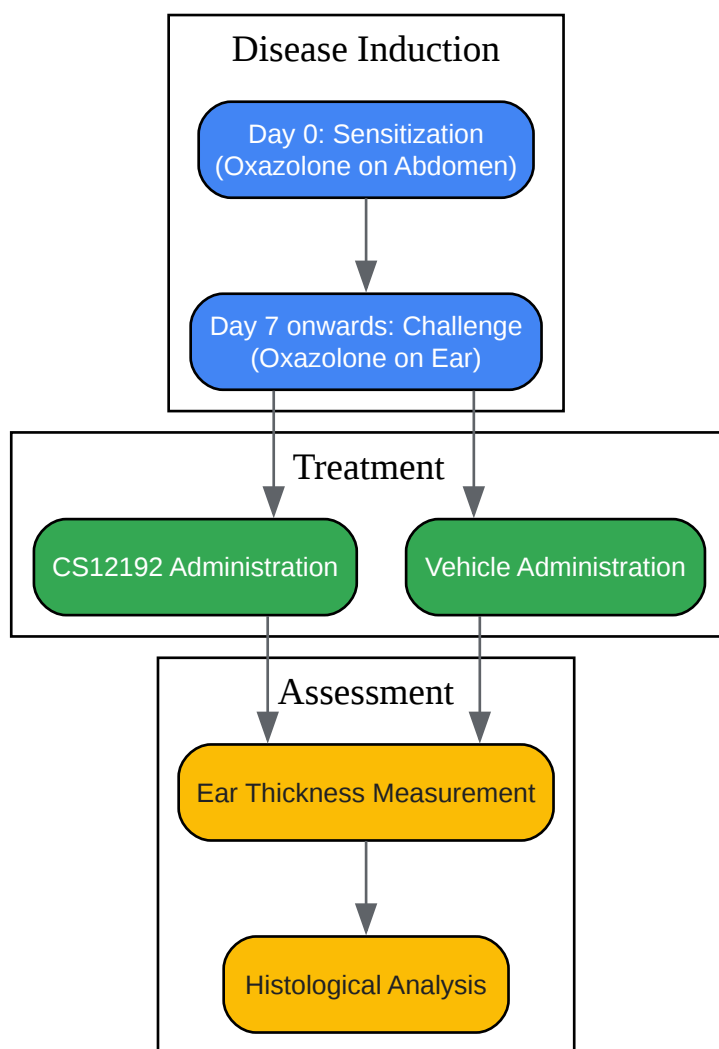

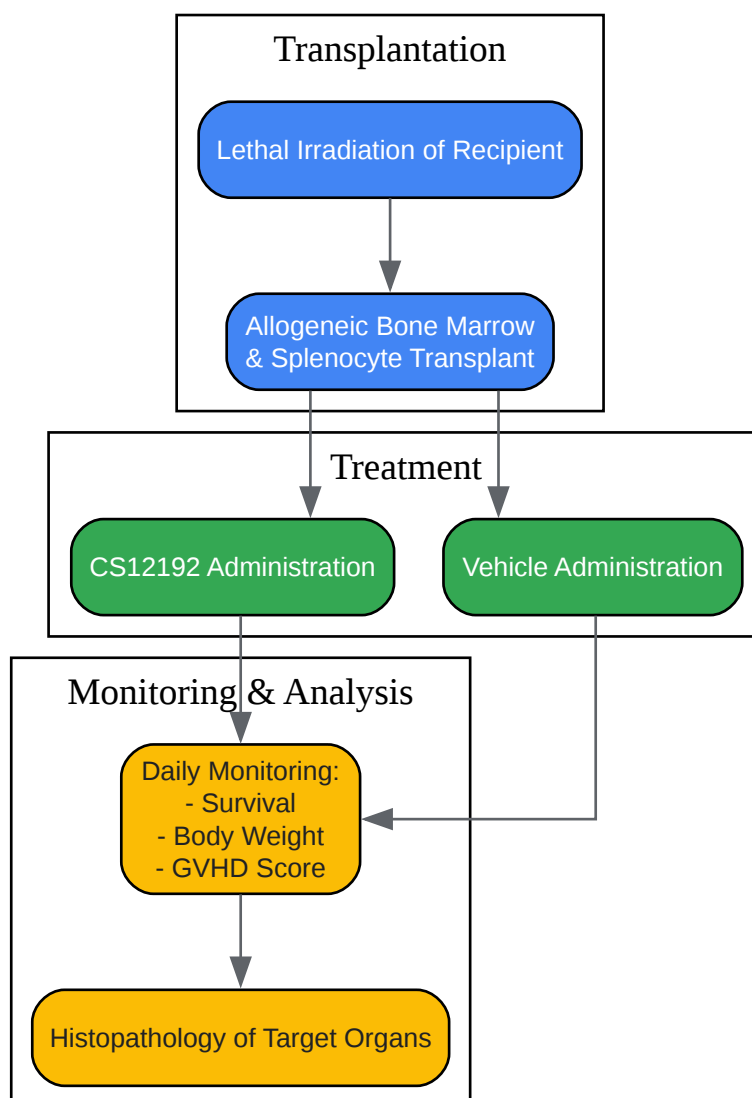

[Click to download full resolution via product page](#)

### Need Custom Synthesis?

BenchChem offers custom synthesis for rare earth carbides and specific isotopic labeling.

Email: [info@benchchem.com](mailto:info@benchchem.com) or [Request Quote Online](#).

## References

- 1. [chondrex.com](http://chondrex.com) [chondrex.com]

- 2. CS12192, a novel JAK3/JAK1/TBK1 inhibitor, attenuates autoimmune dermatoses in murine models - PubMed [pubmed.ncbi.nlm.nih.gov]
- 3. Therapeutic treatment of a novel selective JAK3/JAK1/TBK1 inhibitor, CS12192, in rat and mouse models of rheumatoid arthritis - PubMed [pubmed.ncbi.nlm.nih.gov]
- 4. researchgate.net [researchgate.net]
- 5. researchgate.net [researchgate.net]
- 6. Hooke - Contract Research - Systemic Lupus Erythematosus (SLE) in MRL/lpr Mice [hookelabs.com]
- 7. MRL/lpr Mouse Model - Creative Bioarray | Creative Bioarray [creative-bioarray.com]
- 8. inotiv.com [inotiv.com]
- 9. pharmacologydiscoveryservices.com [pharmacologydiscoveryservices.com]
- To cite this document: BenchChem. [Application Notes and Protocols for CS12192 in Murine Models]. BenchChem, [2026]. [Online PDF]. Available at: [https://www.benchchem.com/product/b15615417/docs#application-notes-and-protocols-for-cs12192-in-murine-models]

---

#### Disclaimer & Data Validity:

The information provided in this document is for Research Use Only (RUO) and is strictly not intended for diagnostic or therapeutic procedures. While BenchChem strives to provide accurate protocols, we make no warranties, express or implied, regarding the fitness of this product for every specific experimental setup.

**Technical Support:** The protocols provided are for reference purposes. Unsure if this reagent suits your experiment?

**Need Industrial/Bulk Grade?** [Request Custom Synthesis Quote](#)

# BenchChem

Our mission is to be the trusted global source of essential and advanced chemicals, empowering scientists and researchers to drive progress in science and industry.

## Contact

Address: 3281 E Guasti Rd  
Ontario, CA 91761, United States  
Phone: (601) 213-4426  
Email: [info@benchchem.com](mailto:info@benchchem.com)

[Contact our Ph.D. Support Team for a compatibility check](#)