

Application Note: Measuring T-Cell Proliferation in Response to SS47 Tfa

Author: BenchChem Technical Support Team. **Date:** April 2026

Compound of Interest

Compound Name: SS47 Tfa
Cat. No.: B15615397

[Get Quote](#)

Audience: Researchers, scientists, and drug development professionals.

Introduction

T-cell proliferation is a fundamental process in the adaptive immune response and a key indicator of T-cell activation.[1] Measuring the extent of T-cell proliferation is crucial for developing novel immunomodulatory therapeutics, assessing vaccine efficacy, and understanding autoimmune diseases and cancer immunology. This document provides detailed protocols for assessing the impact of a test compound, herein referred to as "**SS47 Tfa**," on T-cell proliferation using two robust methods: Carboxyfluorescein Succinimidyl Ester (CFSE) dye dilution measured by flow cytometry and the MTT (3-(4,5-dimethylthiazol-2-yl)-2,5-diphenyltetrazolium bromide) colorimetric assay.

The CFSE assay offers detailed, single-cell level data, allowing for the visualization of successive cell divisions, while the MTT assay provides a high-throughput-compatible method to assess overall cell viability and metabolic activity, which correlates with proliferation.[2][3]

Core Principles of T-Cell Activation and Proliferation

T-cell activation is initiated by the engagement of the T-cell receptor (TCR) with an antigen presented by an antigen-presenting cell (APC) (Signal 1).[4] A crucial co-stimulatory signal, often through the interaction of CD28 on the T-cell with B7 molecules on the APC, is required for full activation and to prevent anergy (Signal 2).[5] In vitro, this process can be mimicked using antibodies against CD3 (part of the TCR complex) and CD28.[4][5] Following activation, cytokine signaling, particularly Interleukin-2 (IL-2), drives the clonal expansion and differentiation of T-cells (Signal 3).

Visualization of Key Processes

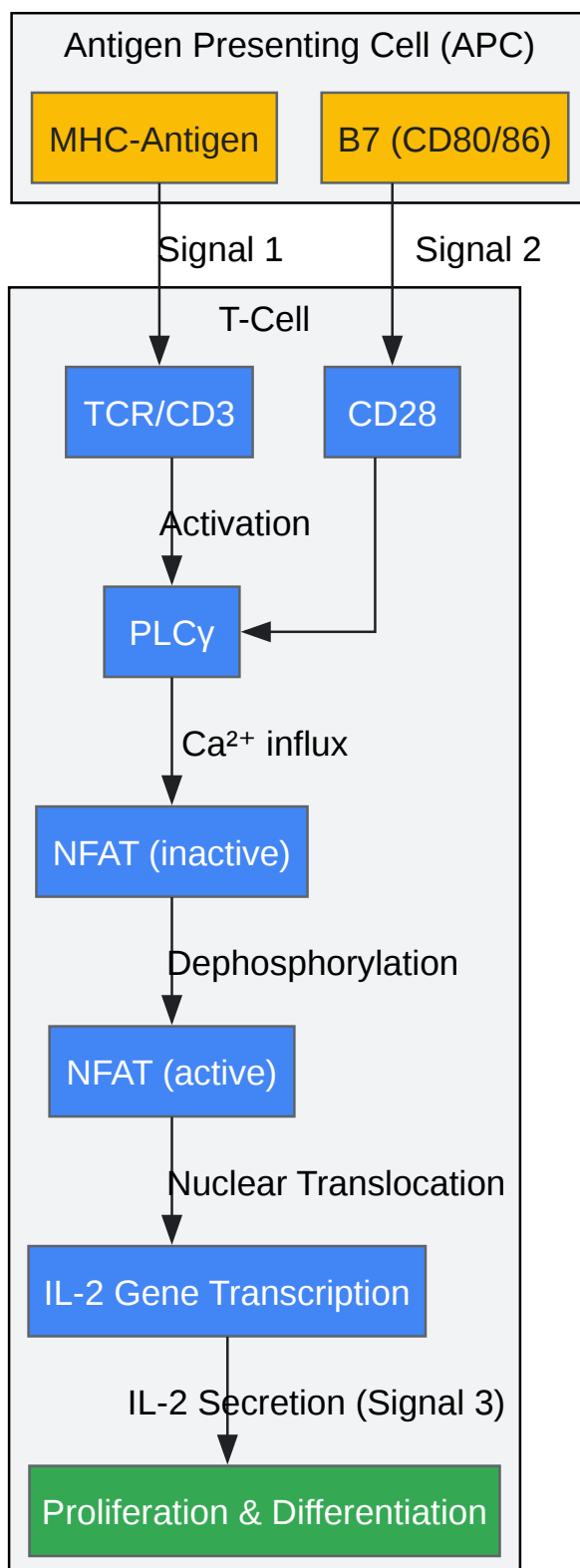

[Click to download full resolution via product page](#)

Caption: Simplified signaling pathway of T-cell activation leading to proliferation.

Experimental Protocols

Protocol 1: CFSE Dye Dilution Assay for T-Cell Proliferation

This method tracks cell divisions by measuring the progressive halving of CFSE fluorescence in daughter cells.[3]

Materials

- Peripheral Blood Mononuclear Cells (PBMCs) or isolated T-cells
- Complete RPMI-1640 medium (supplemented with 10% FBS, 2 mM L-glutamine, 100 U/mL penicillin-streptomycin)
- Phosphate-Buffered Saline (PBS)
- Carboxyfluorescein Succinimidyl Ester (CFSE) dye
- Anti-CD3 and Anti-CD28 antibodies (functional grade)[4]
- **SS47 Tfa** (test compound) and vehicle control (e.g., DMSO)
- 96-well U-bottom culture plate
- FACS tubes and FACS buffer (PBS with 2% FBS)
- Flow cytometer

Methodology

- Cell Preparation:
 - Isolate PBMCs from whole blood using Ficoll-Paque density gradient centrifugation.[6]
 - Wash cells twice with PBS and resuspend in PBS at a concentration of $10\text{-}20 \times 10^6$ cells/mL.[7]
- CFSE Labeling:

- Warm an aliquot of CFSE stock solution to room temperature.
- Add CFSE to the cell suspension to a final concentration of 1-5 μM .^[8] Immediately vortex gently to ensure uniform labeling.
- Incubate for 10-15 minutes at 37°C, protected from light.^[9]
- Quench the staining reaction by adding 5 volumes of ice-cold complete RPMI medium.^[8]
- Wash the cells twice with complete RPMI medium to remove unbound dye.
- Resuspend the labeled cells in complete RPMI medium at 1×10^6 cells/mL.
- Cell Culture and Treatment:
 - Coat wells of a 96-well plate with anti-CD3 antibody (e.g., 1 $\mu\text{g}/\text{mL}$ in PBS) by incubating for at least 2 hours at 37°C.^[8] Wash wells twice with sterile PBS before adding cells.
 - Seed 100 μL of CFSE-labeled cell suspension (1×10^5 cells) into each well.
 - Prepare serial dilutions of **SS47 Tfa** in complete RPMI medium. Add the desired volume (e.g., 100 μL) to the wells. Include appropriate controls:
 - Unstimulated Control: Cells with no stimulation.
 - Vehicle Control: Stimulated cells treated with the vehicle used to dissolve **SS47 Tfa**.
 - Positive Control: Stimulated cells with no test compound.
 - Add soluble anti-CD28 antibody to all stimulated wells to a final concentration of 1-2 $\mu\text{g}/\text{mL}$.^[10]
 - Incubate the plate for 72-96 hours at 37°C in a humidified 5% CO_2 incubator.
- Flow Cytometry Analysis:
 - Harvest cells from each well and transfer to FACS tubes.
 - Wash cells with FACS buffer.

- Analyze samples on a flow cytometer, exciting with a 488 nm laser and detecting emission in the FITC channel.
- Gate on the live, single-cell population.
- On a histogram of CFSE fluorescence, the undivided cells will form a bright peak. Each subsequent peak of halved fluorescence intensity represents a generation of proliferating cells.[2]

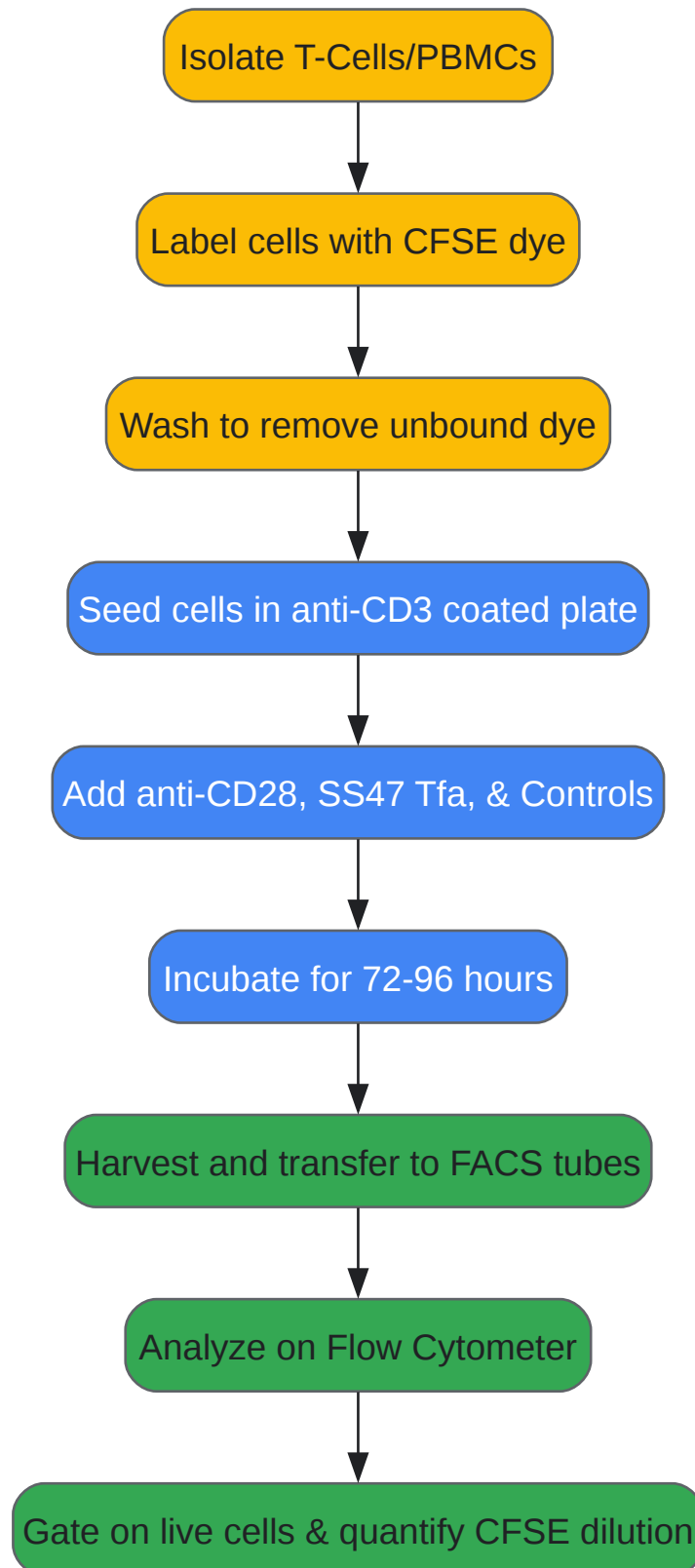

[Click to download full resolution via product page](#)

Caption: Experimental workflow for the CFSE T-cell proliferation assay.

Protocol 2: MTT Assay for T-Cell Proliferation

This colorimetric assay measures the metabolic activity of cells, which is an indirect measure of cell viability and proliferation.

Materials

- PBMCs or isolated T-cells
- Complete RPMI-1640 medium
- Anti-CD3 and Anti-CD28 antibodies[4]
- **SS47 Tfa** and vehicle control
- 96-well flat-bottom culture plate
- MTT reagent (5 mg/mL in PBS)
- Solubilization solution (e.g., 10% SDS in 0.01 M HCl or DMSO)[11]
- Microplate reader

Methodology

- Cell Preparation and Seeding:
 - Isolate and prepare T-cells as described in Protocol 1, Step 1.
 - Resuspend cells in complete RPMI medium at 1×10^6 cells/mL.
 - Follow the stimulation and treatment setup as described in Protocol 1, Step 3, using a flat-bottom plate.
- Incubation:
 - Incubate the plate for 48-72 hours at 37°C in a humidified 5% CO₂ incubator.
- MTT Assay:

- Add 10 μ L of MTT reagent (5 mg/mL) to each well.
- Incubate the plate for an additional 2-4 hours at 37°C, allowing viable cells to convert the yellow MTT into purple formazan crystals.
- Add 100 μ L of solubilization solution to each well.[\[11\]](#)
- Incubate the plate for at least 2 hours at room temperature in the dark, shaking gently to ensure all formazan crystals are dissolved.
- Data Acquisition:
 - Read the absorbance at 570 nm using a microplate reader.

Data Presentation and Analysis

Quantitative data should be summarized to facilitate comparison between different concentrations of **SS47 Tfa**.

CFSE Data Analysis Flow cytometry software can be used to calculate various proliferation metrics:[\[12\]](#)

- Percent Divided: The percentage of cells that have undergone at least one division.
- Division Index: The average number of divisions for all cells in the original population.

MTT Data Analysis

- Subtract the average absorbance of the blank (medium only) wells from all other readings.
- Calculate the percentage of proliferation relative to the positive control (stimulated, no compound):
 - % Proliferation = $(\text{Absorbance_Sample} / \text{Absorbance_PositiveControl}) \times 100$
- If **SS47 Tfa** is inhibitory, calculate the percentage of inhibition:
 - % Inhibition = $100 - \% \text{ Proliferation}$

- Plot the % Inhibition against the log concentration of **SS47 Tfa** to determine the IC₅₀ value (the concentration that inhibits proliferation by 50%).

Example Data Tables

 Table 1: Effect of **SS47 Tfa** on T-Cell Proliferation (MTT Assay)

SS47 Tfa Conc. (µM)	Mean Absorbance (570 nm)	Std. Deviation	% Proliferation	% Inhibition
0 (Unstimulated)	0.150	0.015	10.0%	90.0%
0 (Vehicle Control)	1.500	0.080	100.0%	0.0%
0.01	1.350	0.075	90.0%	10.0%
0.1	1.050	0.060	70.0%	30.0%
1	0.765	0.055	51.0%	49.0%
10	0.450	0.040	30.0%	70.0%
100	0.225	0.025	15.0%	85.0%

Table 2: Proliferation Metrics from CFSE Analysis

Condition	SS47 Tfa Conc. (µM)	Percent Divided (%)	Division Index
Unstimulated	0	5.2	0.06
Vehicle Control	0	85.6	1.85
SS47 Tfa	1	43.1	0.92
SS47 Tfa	10	25.8	0.45

Need Custom Synthesis?

BenchChem offers custom synthesis for rare earth carbides and specific isotopic labeling.

Email: info@benchchem.com or [Request Quote Online](#).

References

- [1. academic.oup.com \[academic.oup.com\]](https://academic.oup.com)
- [2. biocompare.com \[biocompare.com\]](https://biocompare.com)
- [3. reactionbiology.com \[reactionbiology.com\]](https://reactionbiology.com)
- [4. T Cell Activation via Anti-CD3 and Anti-CD28 Protocol | Thermo Fisher Scientific - HK \[thermofisher.com\]](#)
- [5. T cell stimulation and expansion using anti-CD3/CD28 beads - PubMed \[pubmed.ncbi.nlm.nih.gov\]](#)
- [6. CellTrace CFSE Cell Proliferation Kit Protocol | Thermo Fisher Scientific - KR \[thermofisher.com\]](#)
- [7. bu.edu \[bu.edu\]](https://bu.edu)
- [8. agilent.com \[agilent.com\]](https://agilent.com)
- [9. CFSE Cell Proliferation Assay - Creative Bioarray - Creative Bioarray | Creative Bioarray \[creative-bioarray.com\]](#)
- [10. Frontiers | Regulatory T Cells Suppress Effector T Cell Proliferation by Limiting Division Destiny \[frontiersin.org\]](#)
- [11. CyQUANT MTT Cell Proliferation Assay Kit Protocol | Thermo Fisher Scientific - TW \[thermofisher.com\]](#)
- [12. Flow Cytometry Proliferation Analysis \[denovosoftware.com\]](https://denovosoftware.com)
- To cite this document: BenchChem. [Application Note: Measuring T-Cell Proliferation in Response to SS47 Tfa]. BenchChem, [2026]. [Online PDF]. Available at: [\[https://www.benchchem.com/product/b15615397/docs#application-note-measuring-t-cell-proliferation-in-response-to-ss47-tfa\]](https://www.benchchem.com/product/b15615397/docs#application-note-measuring-t-cell-proliferation-in-response-to-ss47-tfa)

Disclaimer & Data Validity:

The information provided in this document is for Research Use Only (RUO) and is strictly not intended for diagnostic or therapeutic procedures. While BenchChem strives to provide accurate protocols, we make no warranties, express or implied, regarding the fitness of this product for every specific experimental setup.

Technical Support: The protocols provided are for reference purposes. Unsure if this reagent suits your experiment?

Need Industrial/Bulk Grade? [Request Custom Synthesis Quote](#)

BenchChem

Our mission is to be the trusted global source of essential and advanced chemicals, empowering scientists and researchers to drive progress in science and industry.

Contact

Address: 3281 E Guasti Rd
Ontario, CA 91761, United States
Phone: (601) 213-4426
Email: info@benchchem.com

[Contact our Ph.D. Support Team for a compatibility check](#)