

A Comparative Guide to the Downstream Targets of MOTS-c

Author: BenchChem Technical Support Team. **Date:** April 2026

Compound of Interest

Compound Name: MOTS-c(Human) Acetate

Cat. No.: B15615933

[Get Quote](#)

For Researchers, Scientists, and Drug Development Professionals

This guide provides a comprehensive comparison of the downstream molecular targets of the mitochondrial-derived peptide (MDP) MOTS-c, alongside two other key metabolic modulators: the fellow MDP Humanin and the widely-used anti-diabetic drug metformin. This objective analysis is supported by available experimental data to aid in the evaluation of their respective mechanisms of action and therapeutic potential.

At a Glance: Comparative Overview of MOTS-c and Alternatives

Feature	MOTS-c	Humanin	Metformin
Primary Mechanism	Inhibition of the folate-methionine cycle, leading to AICAR accumulation and subsequent AMPK activation. ^[1]	Binds to cell surface receptors (GP130/IL6ST, FPRL1) to activate multiple signaling cascades.	Inhibition of mitochondrial respiratory chain complex I, leading to an increased AMP:ATP ratio and subsequent AMPK activation.
Key Signaling Pathway	Folate-AICAR-AMPK	AKT, ERK1/2, STAT3, and to some extent, AMPK	AMPK
Primary Target Tissues	Skeletal muscle, adipose tissue	Broad, including neurons, cardiomyocytes, and immune cells	Liver, skeletal muscle
Key Downstream Effects	Enhanced insulin sensitivity, increased glucose uptake, increased fatty acid oxidation, regulation of gene expression (antioxidant response). ^{[1][2]}	Cytoprotection, anti-apoptosis, anti-inflammatory effects, and metabolic regulation.	Decreased hepatic gluconeogenesis, increased muscle glucose uptake, and systemic improvement in insulin sensitivity.

Delving Deeper: A Head-to-Head Analysis of Downstream Signaling

The signaling pathways initiated by MOTS-c, Humanin, and metformin, while converging on some common metabolic outcomes, are initiated by distinct upstream events and engage different downstream effectors.

MOTS-c: A Central Role for the Folate-AICAR-AMPK Axis

MOTS-c exerts its effects primarily by targeting the folate-methionine cycle. This leads to the intracellular accumulation of 5-aminoimidazole-4-carboxamide ribonucleotide (AICAR), a natural analog of AMP, which in turn allosterically activates AMP-activated protein kinase (AMPK), a master regulator of cellular energy homeostasis.[1] Activated AMPK then phosphorylates a cascade of downstream targets to orchestrate a coordinated metabolic response. Furthermore, under conditions of metabolic stress, MOTS-c can translocate to the nucleus and modulate the expression of genes containing antioxidant response elements (AREs) through its interaction with transcription factors such as NRF2.[3][4]

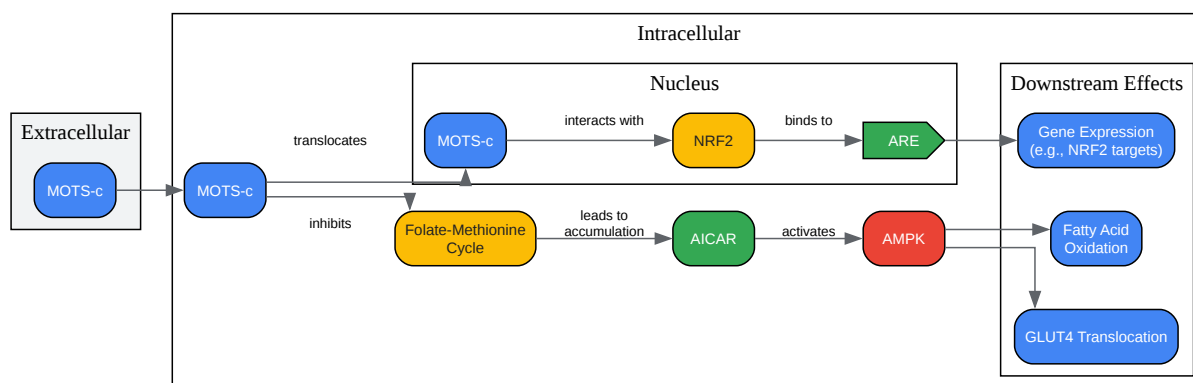

[Click to download full resolution via product page](#)

MOTS-c Signaling Pathway

Humanin: A Pleiotropic Peptide with Diverse Signaling Actions

In contrast to the focused mechanism of MOTS-c, Humanin engages multiple cell surface receptors, including the GP130/IL6ST complex and the formyl peptide receptor-like 1 (FPRL1), to initiate a broader range of intracellular signaling cascades.[5][6] This leads to the activation of several key pro-survival and metabolic pathways, including the PI3K/AKT, MAPK/ERK1/2,

and JAK/STAT3 pathways.[5][6] While some studies suggest Humanin can also activate AMPK, this does not appear to be its primary mode of action.[7]

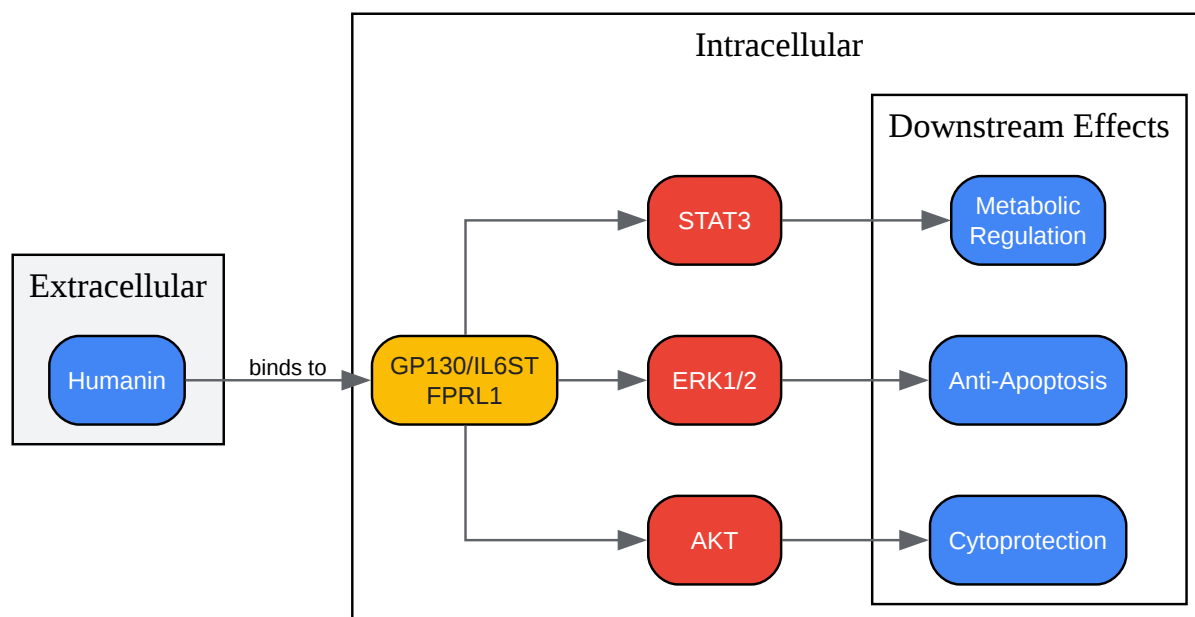

[Click to download full resolution via product page](#)

Humanin Signaling Pathway

Metformin: The Established AMPK Activator

Metformin's primary molecular action is the inhibition of complex I of the mitochondrial respiratory chain. This leads to a decrease in cellular ATP levels and a corresponding increase in the AMP:ATP ratio, which is a potent activator of AMPK.[8] The subsequent activation of AMPK in key metabolic tissues, particularly the liver and skeletal muscle, mediates the majority of metformin's therapeutic effects, including the suppression of hepatic gluconeogenesis and the enhancement of insulin-stimulated glucose uptake in muscle.[8][9]

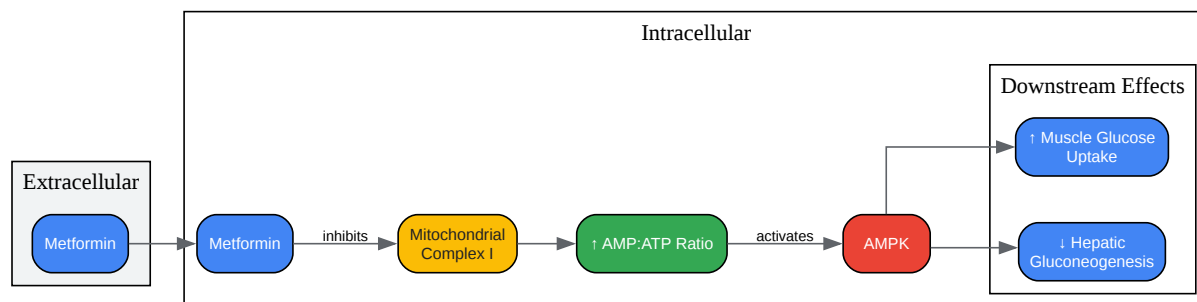

[Click to download full resolution via product page](#)

Metformin Signaling Pathway

Quantitative Comparison of Downstream Target Activation

Direct comparative studies with standardized quantitative data for MOTS-c, Humanin, and metformin are limited. The following tables summarize available data from individual studies, highlighting the experimental context.

Table 1: Effects on AMPK Activation

Compound	Cell/Tissue Type	Concentration/Dose	Fold Change in p-AMPK/AMPK	Reference
MOTS-c	HEK293 cells	10 μ M	Time- and dose-dependent increase	[10]
MOTS-c	C2C12 myotubes	-	Significantly increased	[4]
Humanin	Mouse bone marrow macrophages	-	Significantly induced	[5]
Metformin	C2C12 myoblasts	400 μ M - 1mM	Dose-dependent increase	[11][12]
Metformin	Human skeletal muscle (in vivo)	Therapeutic doses	Significant increase in AMPK α 2 activity	[13]

Table 2: Effects on Glucose Uptake and GLUT4 Translocation

Compound	Cell/Tissue Type	Concentration/Dose	Effect on Glucose Uptake/GLUT4 Translocation	Reference
MOTS-c	Myocytes	Overexpression	Increased glucose uptake	[1]
MOTS-c	D12 adipocytes	100 μ M	Prompts GLUT4 translocation	[14][15][16]
Metformin	L6 muscle cells	800 μ M	Increased GLUT4 in plasma membrane	-

Table 3: Effects on Other Key Downstream Targets

Compound	Target	Cell/Tissue Type	Effect	Reference
MOTS-c	NRF2	MLE-12 cells	Increased content and nuclear translocation	[17][18]
Humanin	p-AKT	Old mouse hippocampus	Increased phosphorylation	[5]
Humanin	p-ERK1/2	HEK293 cells	Rapid increase in phosphorylation	[5]
Metformin	Hepatic Gluconeogenesis	Perfused rat liver	Flux from lactate to glucose halved	[9][19]

Experimental Protocols

Detailed methodologies are crucial for the replication and validation of experimental findings. Below are summaries of protocols for key experiments cited in the literature.

Quantification of AICAR Levels by LC-MS/MS

- Objective: To measure the intracellular accumulation of AICAR following treatment with an investigational compound.
- Methodology:
 - Sample Preparation: Cells are lysed, and proteins are precipitated. The supernatant containing metabolites is collected.
 - Chromatography: The sample is injected into a liquid chromatography system to separate AICAR from other cellular components.

- Mass Spectrometry: The separated sample is introduced into a mass spectrometer for detection and quantification of AICAR based on its mass-to-charge ratio.
- Data Analysis: AICAR levels are quantified by comparing the signal to a standard curve of known AICAR concentrations.

GLUT4 Translocation Assay (Immunofluorescence)

- Objective: To visualize and quantify the movement of GLUT4 from intracellular vesicles to the plasma membrane.
- Methodology:
 - Cell Culture: Adipocytes or muscle cells are grown on coverslips.
 - Treatment: Cells are treated with the compound of interest (e.g., MOTS-c).
 - Fixation and Permeabilization: Cells are fixed to preserve their structure and permeabilized to allow antibody access.
 - Immunostaining: Cells are incubated with a primary antibody specific for GLUT4, followed by a fluorescently labeled secondary antibody.
 - Imaging: The localization of GLUT4 is visualized using fluorescence microscopy.
 - Quantification: The intensity of fluorescence at the plasma membrane is quantified to determine the extent of GLUT4 translocation.

Western Blot for AMPK Phosphorylation

- Objective: To measure the activation of AMPK by detecting its phosphorylation at Threonine 172.
- Methodology:
 - Protein Extraction: Cells or tissues are lysed to extract total protein.
 - Protein Quantification: The concentration of total protein in each sample is determined.

- SDS-PAGE: Equal amounts of protein are separated by size using sodium dodecyl sulfate-polyacrylamide gel electrophoresis.
- Protein Transfer: The separated proteins are transferred from the gel to a membrane.
- Immunoblotting: The membrane is incubated with a primary antibody that specifically recognizes phosphorylated AMPK (p-AMPK), followed by a secondary antibody conjugated to an enzyme that produces a detectable signal. A separate blot is performed with an antibody for total AMPK as a loading control.
- Detection and Quantification: The signal from the p-AMPK and total AMPK bands is detected and quantified. The ratio of p-AMPK to total AMPK is calculated to determine the level of AMPK activation.

Conclusion

MOTS-c, Humanin, and metformin are all potent modulators of cellular metabolism with significant therapeutic potential. While they share the common downstream effector of AMPK, their upstream mechanisms of action and the breadth of their signaling networks differ significantly. MOTS-c acts through a unique pathway involving the folate cycle and AICAR accumulation, positioning it as a novel regulator of metabolic homeostasis. Humanin demonstrates pleiotropic effects through the activation of multiple pro-survival signaling pathways. Metformin remains a cornerstone of metabolic disease therapy, primarily through its well-established role as an inhibitor of mitochondrial respiration and a potent activator of AMPK.

For researchers and drug development professionals, the choice of which molecule to investigate or develop further will depend on the specific therapeutic indication and the desired molecular targets. The distinct signaling profiles of these compounds offer a range of opportunities for targeted interventions in metabolic and age-related diseases. Further head-to-head comparative studies with robust quantitative data are warranted to fully elucidate their relative potencies and therapeutic windows.

Need Custom Synthesis?

BenchChem offers custom synthesis for rare earth carbides and specific isotopic labeling.

Email: info@benchchem.com or [Request Quote Online](#).

References

- 1. MOTS-c: A novel mitochondrial-derived peptide regulating muscle and fat metabolism - PMC [[pmc.ncbi.nlm.nih.gov](https://pubmed.ncbi.nlm.nih.gov/)]
- 2. MOTS-c: A promising mitochondrial-derived peptide for therapeutic exploitation - PMC [[pmc.ncbi.nlm.nih.gov](https://pubmed.ncbi.nlm.nih.gov/)]
- 3. The Mitochondrial-Encoded Peptide MOTS-c Translocates to the Nucleus to Regulate Nuclear Gene Expression in Response to Metabolic Stress - PMC [[pmc.ncbi.nlm.nih.gov](https://pubmed.ncbi.nlm.nih.gov/)]
- 4. MOTS-c, the Most Recent Mitochondrial Derived Peptide in Human Aging and Age-Related Diseases - PMC [[pmc.ncbi.nlm.nih.gov](https://pubmed.ncbi.nlm.nih.gov/)]
- 5. The mitochondrial-derived peptide humanin activates the ERK1/2, AKT, and STAT3 signaling pathways and has age-dependent signaling differences in the hippocampus - PMC [[pmc.ncbi.nlm.nih.gov](https://pubmed.ncbi.nlm.nih.gov/)]
- 6. The mitochondrial-derived peptide humanin activates the ERK1/2, AKT, and STAT3 signaling pathways and has age-dependent signaling differences in the hippocampus - PubMed [pubmed.ncbi.nlm.nih.gov]
- 7. Protective Mechanism of Humanin Against Oxidative Stress in Aging-Related Cardiovascular Diseases - PMC [[pmc.ncbi.nlm.nih.gov](https://pubmed.ncbi.nlm.nih.gov/)]
- 8. Role of AMP-activated protein kinase in mechanism of metformin action - PMC [[pmc.ncbi.nlm.nih.gov](https://pubmed.ncbi.nlm.nih.gov/)]
- 9. Effects of metformin on lactate uptake and gluconeogenesis in the perfused rat liver - PubMed [pubmed.ncbi.nlm.nih.gov]
- 10. The Mitochondrial-derived peptide MOTS-c promotes metabolic homeostasis and reduces obesity and insulin resistance - PMC [[pmc.ncbi.nlm.nih.gov](https://pubmed.ncbi.nlm.nih.gov/)]
- 11. Metformin regulates myoblast differentiation through an AMPK-dependent mechanism - PMC [[pmc.ncbi.nlm.nih.gov](https://pubmed.ncbi.nlm.nih.gov/)]
- 12. [researchgate.net](https://www.researchgate.net/) [[researchgate.net](https://www.researchgate.net/)]
- 13. [researchgate.net](https://www.researchgate.net/) [[researchgate.net](https://www.researchgate.net/)]
- 14. [genscript.com](https://www.genscript.com/) [[genscript.com](https://www.genscript.com/)]
- 15. [researchgate.net](https://www.researchgate.net/) [[researchgate.net](https://www.researchgate.net/)]
- 16. [researchgate.net](https://www.researchgate.net/) [[researchgate.net](https://www.researchgate.net/)]
- 17. [mdpi.com](https://www.mdpi.com/) [[mdpi.com](https://www.mdpi.com/)]
- 18. [researchgate.net](https://www.researchgate.net/) [[researchgate.net](https://www.researchgate.net/)]

- [19. diabetesjournals.org \[diabetesjournals.org\]](https://diabetesjournals.org)
- To cite this document: BenchChem. [A Comparative Guide to the Downstream Targets of MOTS-c]. BenchChem, [2026]. [Online PDF]. Available at: [\[https://www.benchchem.com/product/b15615933/docs#a-comparative-guide-to-the-downstream-targets-of-mots-c\]](https://www.benchchem.com/product/b15615933/docs#a-comparative-guide-to-the-downstream-targets-of-mots-c)

Disclaimer & Data Validity:

The information provided in this document is for Research Use Only (RUO) and is strictly not intended for diagnostic or therapeutic procedures. While BenchChem strives to provide accurate protocols, we make no warranties, express or implied, regarding the fitness of this product for every specific experimental setup.

Technical Support: The protocols provided are for reference purposes. Unsure if this reagent suits your experiment?

Need Industrial/Bulk Grade? [Request Custom Synthesis Quote](#)

BenchChem

Our mission is to be the trusted global source of essential and advanced chemicals, empowering scientists and researchers to drive progress in science and industry.

Contact

Address: 3281 E Guasti Rd
Ontario, CA 91761, United States
Phone: (601) 213-4426
Email: info@benchchem.com

[Contact our Ph.D. Support Team for a compatibility check](#)