

A Comparative Guide: Osimertinib vs. Next-Generation EGFR Inhibitors

Author: BenchChem Technical Support Team. **Date:** April 2026

Compound of Interest

Compound Name: *Egfr-IN-120*

Cat. No.: *B15615283*

[Get Quote](#)

For Researchers, Scientists, and Drug Development Professionals

The landscape of targeted therapy for non-small cell lung cancer (NSCLC) driven by epidermal growth factor receptor (EGFR) mutations is in continuous evolution. Osimertinib, a third-generation EGFR tyrosine kinase inhibitor (TKI), has established itself as a standard of care, effectively targeting both sensitizing mutations and the common T790M resistance mutation. However, the emergence of further resistance mechanisms, notably the C797S mutation, necessitates the development of next-generation inhibitors. This guide provides a detailed comparison of osimertinib with a representative fourth-generation EGFR inhibitor, herein referred to as **EGFR-IN-120**, designed to overcome C797S-mediated resistance.

Executive Summary

Osimertinib is a potent, irreversible EGFR-TKI that selectively inhibits sensitizing and T790M resistance mutations while sparing wild-type (WT) EGFR. Its efficacy is well-documented in extensive clinical trials. **EGFR-IN-120** represents a class of fourth-generation inhibitors developed to address the clinical challenge of acquired resistance to osimertinib, primarily through the C797S mutation. These newer agents often employ alternative binding mechanisms to circumvent the resistance conferred by the C797S substitution. This guide will

delve into their mechanisms of action, inhibitory profiles, and the experimental data that underpins their development and potential clinical utility.

Mechanism of Action

Osimertinib: As a third-generation inhibitor, osimertinib forms a covalent bond with the cysteine residue at position 797 (C797) in the ATP-binding site of the EGFR kinase domain.[1][2] This irreversible binding effectively blocks EGFR signaling pathways, leading to the inhibition of cancer cell proliferation and survival.[2] Its selectivity for mutant EGFR over WT-EGFR contributes to a favorable therapeutic window.[2]

EGFR-IN-120 (Representative Fourth-Generation Inhibitor): To overcome resistance mediated by the C797S mutation, which prevents covalent binding by osimertinib, fourth-generation inhibitors are being developed with non-covalent, reversible, or allosteric mechanisms of action.[1][3][4] These inhibitors are designed to bind to the ATP-binding site of EGFR even with the C797S mutation present, thereby inhibiting the kinase activity of the triple-mutant (e.g., Del19/T790M/C797S or L858R/T790M/C797S) EGFR.[1][5]

Data Presentation

Table 1: Comparative Inhibitory Activity (IC50, nM)

Target	Osimertinib	EGFR-IN-120 (Representative 4th Gen)
EGFR (WT)	~500	Variable, designed for selectivity
EGFR (L858R)	~12	Potent inhibition
EGFR (Exon 19 Del)	Potent inhibition	Potent inhibition
EGFR (L858R/T790M)	~1	Potent inhibition
EGFR (Exon 19 Del/T790M)	Potent inhibition	Potent inhibition
EGFR (L858R/T790M/C797S)	>1000 (Ineffective)	Potent inhibition (e.g., <100 nM)
EGFR (Exon 19 Del/T790M/C797S)	>1000 (Ineffective)	Potent inhibition (e.g., <100 nM)

Note: IC50 values are compiled from various preclinical studies and are approximate.[5][6] The values for **EGFR-IN-120** are representative of fourth-generation inhibitors in development.

Table 2: Summary of Key Characteristics

Feature	Osimertinib	EGFR-IN-120 (Representative 4th Gen)
Generation	Third	Fourth
Mechanism	Irreversible, covalent	Reversible, non-covalent, or allosteric
Primary Target	Sensitizing mutations, T790M	Sensitizing mutations, T790M, C797S
Resistance	C797S mutation, MET amplification	Novel resistance mechanisms under investigation
Clinical Status	FDA Approved	Preclinical and clinical development

Experimental Protocols

In Vitro Kinase Inhibition Assay

Objective: To determine the half-maximal inhibitory concentration (IC50) of the compounds against various EGFR kinase domains.

Methodology:

- Recombinant human EGFR protein (wild-type or mutant) is incubated with the test compound (osimertinib or **EGFR-IN-120**) at varying concentrations in a kinase assay buffer.
- The kinase reaction is initiated by the addition of ATP and a substrate peptide (e.g., a poly-Glu-Tyr peptide).
- The reaction is allowed to proceed for a specified time at a controlled temperature (e.g., 30°C).

- The amount of phosphorylated substrate is quantified using methods such as ELISA, radiometric assay (32P-ATP), or fluorescence-based assays.
- IC50 values are calculated by fitting the dose-response data to a sigmoidal curve using appropriate software.[7]

Cell-Based Proliferation Assay

Objective: To assess the anti-proliferative activity of the compounds in cancer cell lines harboring specific EGFR mutations.

Methodology:

- Human cancer cell lines with known EGFR mutational status (e.g., PC-9 for Exon 19 deletion, H1975 for L858R/T790M, and engineered lines with C797S) are seeded in 96-well plates.
- After cell attachment, they are treated with a range of concentrations of the test compound.
- Cells are incubated for a period of 72 hours.
- Cell viability is measured using a colorimetric assay such as MTT or a fluorescence-based assay like CellTiter-Glo.
- IC50 values are determined from the resulting dose-response curves.[8]

Visualizations

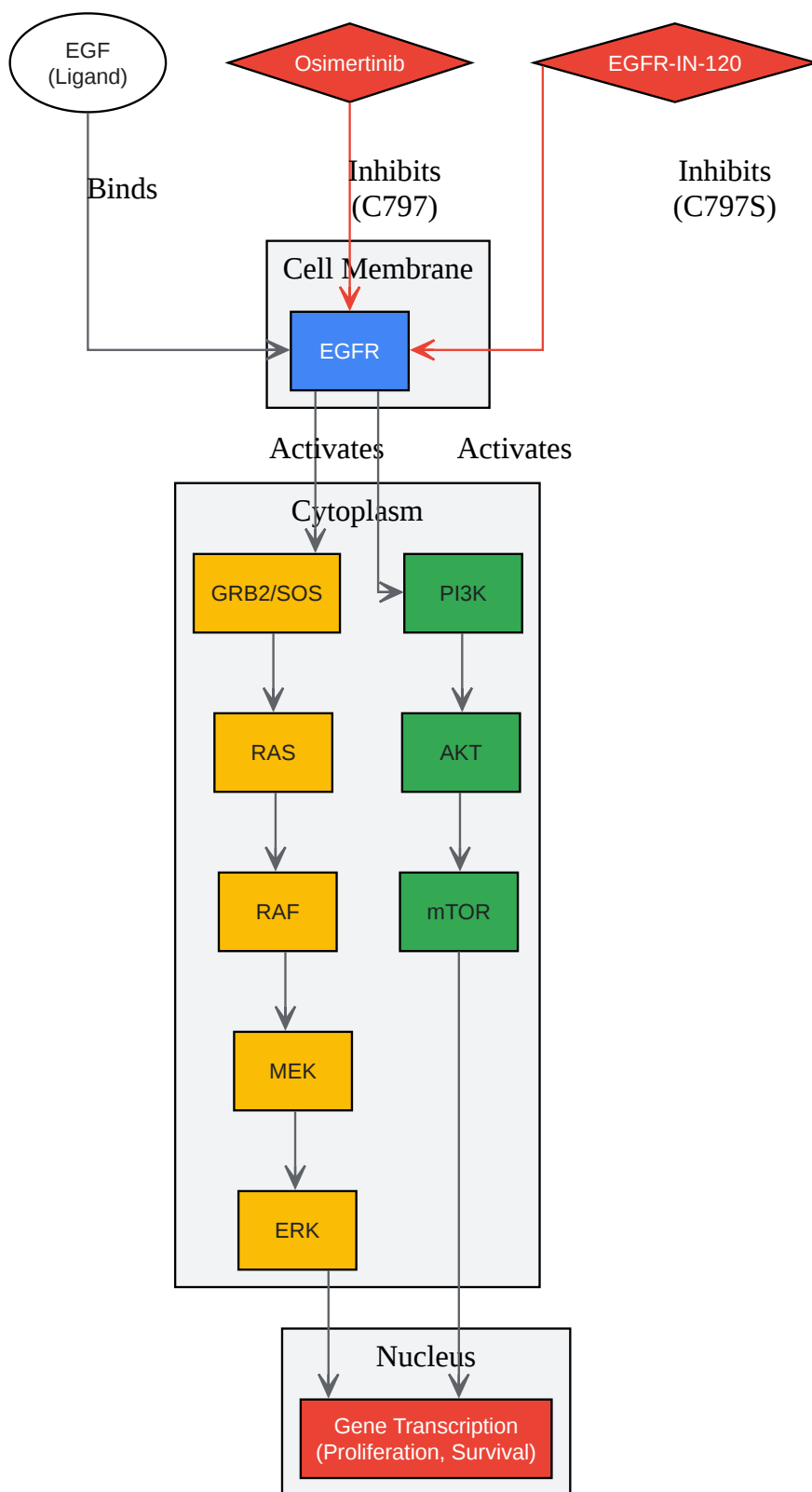

[Click to download full resolution via product page](#)

Caption: EGFR Signaling Pathway and Inhibition.

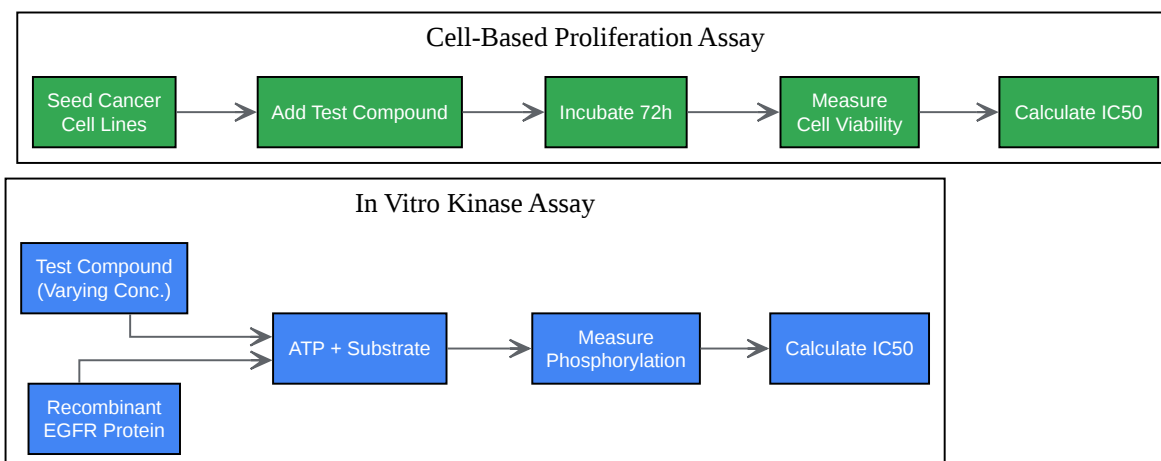

[Click to download full resolution via product page](#)

Caption: Experimental Workflow for Inhibitor Characterization.

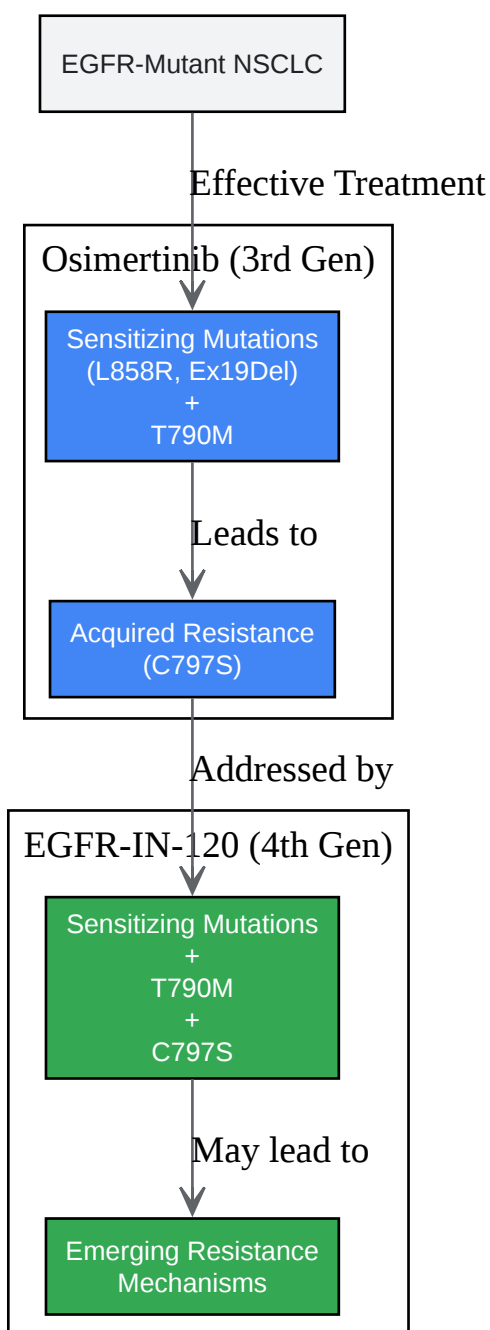

[Click to download full resolution via product page](#)

Need Custom Synthesis?

BenchChem offers custom synthesis for rare earth carbides and specific isotopic labeling.

Email: info@benchchem.com or [Request Quote Online](#).

References

- 1. Chronicles of EGFR Tyrosine Kinase Inhibitors: Targeting EGFR C797S Containing Triple Mutations - PMC [[pmc.ncbi.nlm.nih.gov](https://pubmed.ncbi.nlm.nih.gov/)]
- 2. Mechanisms of Action of EGFR Tyrosine Kinase Receptor Incorporated in Extracellular Vesicles - PMC [[pmc.ncbi.nlm.nih.gov](https://pubmed.ncbi.nlm.nih.gov/)]
- 3. Fourth-generation EGFR-TKI to overcome C797S mutation: past, present, and future - PMC [[pmc.ncbi.nlm.nih.gov](https://pubmed.ncbi.nlm.nih.gov/)]
- 4. Insights into fourth generation selective inhibitors of (C797S) EGFR mutation combating non-small cell lung cancer resistance: a critical review - RSC Advances (RSC Publishing) DOI:10.1039/D3RA02347H [pubs.rsc.org]
- 5. Next-generation EGFR tyrosine kinase inhibitors to overcome C797S mutation in non-small cell lung cancer (2019–2024) - PMC [[pmc.ncbi.nlm.nih.gov](https://pubmed.ncbi.nlm.nih.gov/)]
- 6. Comparative kinase and cancer cell panel profiling of kinase inhibitors approved for clinical use from 2018 to 2020 - PMC [[pmc.ncbi.nlm.nih.gov](https://pubmed.ncbi.nlm.nih.gov/)]
- 7. [researchgate.net](https://www.researchgate.net/) [[researchgate.net](https://www.researchgate.net/)]
- 8. Evaluation of IC50 levels immediately after treatment with anticancer reagents using a real-time cell monitoring device - PMC [[pmc.ncbi.nlm.nih.gov](https://pubmed.ncbi.nlm.nih.gov/)]
- To cite this document: BenchChem. [A Comparative Guide: Osimertinib vs. Next-Generation EGFR Inhibitors]. BenchChem, [2026]. [Online PDF]. Available at: [<https://www.benchchem.com/product/b15615283/docs#a-comparative-guide-osimertinib-vs-next-generation-egfr-inhibitors>]

Disclaimer & Data Validity:

The information provided in this document is for Research Use Only (RUO) and is strictly not intended for diagnostic or therapeutic procedures. While BenchChem strives to provide accurate protocols, we make no warranties, express or implied, regarding the fitness of this product for every specific experimental setup.

Technical Support: The protocols provided are for reference purposes. Unsure if this reagent suits your experiment?

Need Industrial/Bulk Grade? [Request Custom Synthesis Quote](#)

BenchChem

Our mission is to be the trusted global source of essential and advanced chemicals, empowering scientists and researchers to drive progress in science and industry.

Contact

Address: 3281 E Guasti Rd

Ontario, CA 91761, United States

Phone: (601) 213-4426

Email: info@benchchem.com

[Contact our Ph.D. Support Team for a compatibility check](#)