

Technical Support Center: BML-260

Experimental Design and Troubleshooting

Author: BenchChem Technical Support Team. **Date:** April 2026

Compound of Interest

Compound Name: BML-260
Cat. No.: B15614266

[Get Quote](#)

This technical support center provides researchers, scientists, and drug development professionals with comprehensive guidance to minimize variability in experimental results using **BML-260**. The information is presented in a question-and-answer format to directly address common issues and provide clear, actionable solutions.

Frequently Asked Questions (FAQs)

Q1: What is **BML-260** and what is its primary mechanism of action?

A1: **BML-260** is a potent small molecule inhibitor of the dual-specificity phosphatase DUSP22 (also known as JSP-1).^{[1][2][3][4][5]} By inhibiting DUSP22, **BML-260** prevents the dephosphorylation of key signaling proteins, leading to the modulation of downstream pathways. Notably, it has been shown to suppress the activation of the stress-activated kinase JNK and its downstream target FOXO3a, a master regulator of muscle wasting.^{[6][7]} Additionally, **BML-260** can activate CREB, STAT3, and PPAR signaling pathways, and stimulate the expression of UCP1, playing a role in thermogenesis.^{[1][3]}

Q2: What are the common research applications for **BML-260**?

A2: **BML-260** is utilized in research investigating inflammatory and proliferative disorders associated with JNK signaling dysfunction.[1][5] It is also studied for its potential therapeutic effects in metabolic diseases like obesity and in conditions characterized by skeletal muscle wasting, such as sarcopenia.[1][6][7]

Q3: How should **BML-260** be stored to ensure stability?

A3: Proper storage of **BML-260** is critical to maintain its activity and ensure reproducible results. Both powdered and dissolved forms require specific storage conditions to prevent degradation.

Form	Storage Temperature	Duration
Powder	-20°C	Up to 3 years
Powder	4°C	Up to 2 years
In Solvent	-80°C	Up to 6 months
In Solvent	-20°C	Up to 1 month

Data compiled from multiple sources.[1][3] To avoid repeated freeze-thaw cycles, it is recommended to aliquot the stock solution into smaller volumes for single-use applications.[3]

Q4: What is the reported IC50 value for **BML-260**?

A4: The half-maximal inhibitory concentration (IC50) can vary between experimental set-ups. One study reported an IC50 value for **BML-260**'s inhibition of DUSP22 activity.

Target	IC50 Value	Assay Condition
DUSP22	54 µM	In vitro phosphatase assay

This value is from a specific study and may vary depending on the experimental system.[1]

Troubleshooting Guides

Variability in experimental outcomes can arise from multiple sources. This section provides troubleshooting guidance for common issues encountered during **BML-260** experiments.

Issue 1: High Variability in Cell Viability/Cytotoxicity Assays

Q: My cell viability results with **BML-260** are inconsistent across experiments. What are the potential causes and solutions?

A: Variability in cell-based assays is a common challenge.^[8] Several factors related to cell culture and assay execution can contribute to this.

Potential Cause	Troubleshooting Steps
Cell Health and Passage Number	Maintain a consistent cell passage number for all experiments. Cells at very high or low passage numbers can exhibit altered metabolic activity and drug sensitivity. Ensure cells are healthy and in the logarithmic growth phase at the time of treatment.
Inconsistent Seeding Density	Use a precise cell counting method to ensure uniform cell seeding in all wells. Uneven cell distribution can lead to significant variations in the final readout.
Edge Effects in Multi-well Plates	To minimize evaporation and temperature gradients, avoid using the outer wells of the plate for experimental samples. Fill the peripheral wells with sterile PBS or media.
Incomplete Dissolution of BML-260	Ensure BML-260 is fully dissolved in the recommended solvent (e.g., DMSO) before diluting it in culture medium. Precipitates can lead to inaccurate dosing.
Interference with Assay Reagents	Some compounds can interfere with the chemistry of viability assays (e.g., MTT reduction). Consider using an alternative viability assay that relies on a different detection principle (e.g., ATP measurement or live/dead staining).

Issue 2: Inconsistent Results in Western Blotting for Phosphorylated Proteins (e.g., p-STAT3)

Q: I am not seeing a consistent increase in STAT3 phosphorylation after **BML-260** treatment. What could be wrong?

A: Detecting changes in protein phosphorylation requires careful sample handling and optimized Western blotting protocols.

Potential Cause	Troubleshooting Steps
Phosphatase Activity during Lysis	Immediately place cells on ice after treatment and use ice-cold lysis buffer supplemented with a fresh cocktail of phosphatase and protease inhibitors. This is critical to preserve the phosphorylation status of your target protein.
Suboptimal Lysis Buffer	Use a lysis buffer appropriate for phosphorylated proteins. RIPA buffer is often a good starting point.
Low Abundance of Phosphorylated Protein	Increase the amount of protein loaded onto the gel. You may also consider enriching for your target protein through immunoprecipitation before Western blotting.
Inappropriate Blocking Agent	Avoid using milk as a blocking agent when detecting phosphorylated proteins, as it contains phosphoproteins that can increase background noise. Use Bovine Serum Albumin (BSA) in Tris-Buffered Saline with Tween 20 (TBST) instead.
Incorrect Antibody Dilution	Optimize the concentration of your primary and secondary antibodies. Refer to the manufacturer's datasheet for recommended starting dilutions.

Experimental Protocols

Protocol 1: Cell Viability Assessment using MTT Assay

This protocol provides a general framework for assessing the effect of **BML-260** on cell viability.

- **Cell Seeding:** Seed cells in a 96-well plate at a predetermined optimal density and allow them to adhere overnight in a 37°C, 5% CO₂ incubator.

- **Compound Treatment:** Prepare serial dilutions of **BML-260** in culture medium from a concentrated stock solution in DMSO. The final DMSO concentration should be kept constant across all wells and should not exceed 0.5% to avoid solvent-induced cytotoxicity. Replace the medium in the wells with the **BML-260** dilutions. Include appropriate vehicle controls (medium with DMSO).
- **Incubation:** Incubate the plate for the desired treatment duration (e.g., 24, 48, or 72 hours).
- **MTT Addition:** Following incubation, add MTT solution (3-(4,5-dimethylthiazol-2-yl)-2,5-diphenyltetrazolium bromide) to each well at a final concentration of 0.5 mg/mL.
- **Formazan Crystal Formation:** Incubate the plate for 2-4 hours at 37°C to allow for the formation of formazan crystals by viable cells.
- **Crystal Solubilization:** Carefully remove the medium and add a solubilization solution (e.g., DMSO or a solution of 0.01 M HCl in 10% SDS) to each well to dissolve the formazan crystals.
- **Absorbance Measurement:** Measure the absorbance at 570 nm using a microplate reader.
- **Data Analysis:** Calculate cell viability as a percentage of the vehicle-treated control.

Protocol 2: Western Blot Analysis of STAT3 Phosphorylation

This protocol outlines the key steps for detecting changes in STAT3 phosphorylation upon **BML-260** treatment.

- **Cell Treatment and Lysis:**
 - Plate cells and treat with **BML-260** at the desired concentrations and for the appropriate time.
 - After treatment, wash the cells with ice-cold PBS.
 - Lyse the cells on ice using a suitable lysis buffer (e.g., RIPA buffer) supplemented with protease and phosphatase inhibitor cocktails.

- Scrape the cells and collect the lysate.
- Clarify the lysate by centrifugation at 14,000 x g for 15 minutes at 4°C.
- Protein Quantification:
 - Determine the protein concentration of the supernatant using a standard protein assay (e.g., BCA assay).
- Sample Preparation:
 - Mix equal amounts of protein (e.g., 20-30 µg) with Laemmli sample buffer and boil for 5 minutes at 95°C.
- SDS-PAGE and Protein Transfer:
 - Separate the protein samples on an SDS-polyacrylamide gel.
 - Transfer the separated proteins to a PVDF or nitrocellulose membrane.
- Immunoblotting:
 - Block the membrane with 5% BSA in TBST for 1 hour at room temperature.
 - Incubate the membrane with a primary antibody specific for phosphorylated STAT3 (p-STAT3) overnight at 4°C.
 - Wash the membrane three times with TBST.
 - Incubate with an appropriate HRP-conjugated secondary antibody for 1 hour at room temperature.
 - Wash the membrane again three times with TBST.
- Detection:
 - Detect the signal using an enhanced chemiluminescence (ECL) substrate and image the blot.

- Stripping and Reprobing (Optional):
 - To normalize for protein loading, the membrane can be stripped and reprobed with an antibody against total STAT3 or a housekeeping protein like GAPDH or β -actin.

Visualizations

Signaling Pathways and Workflows

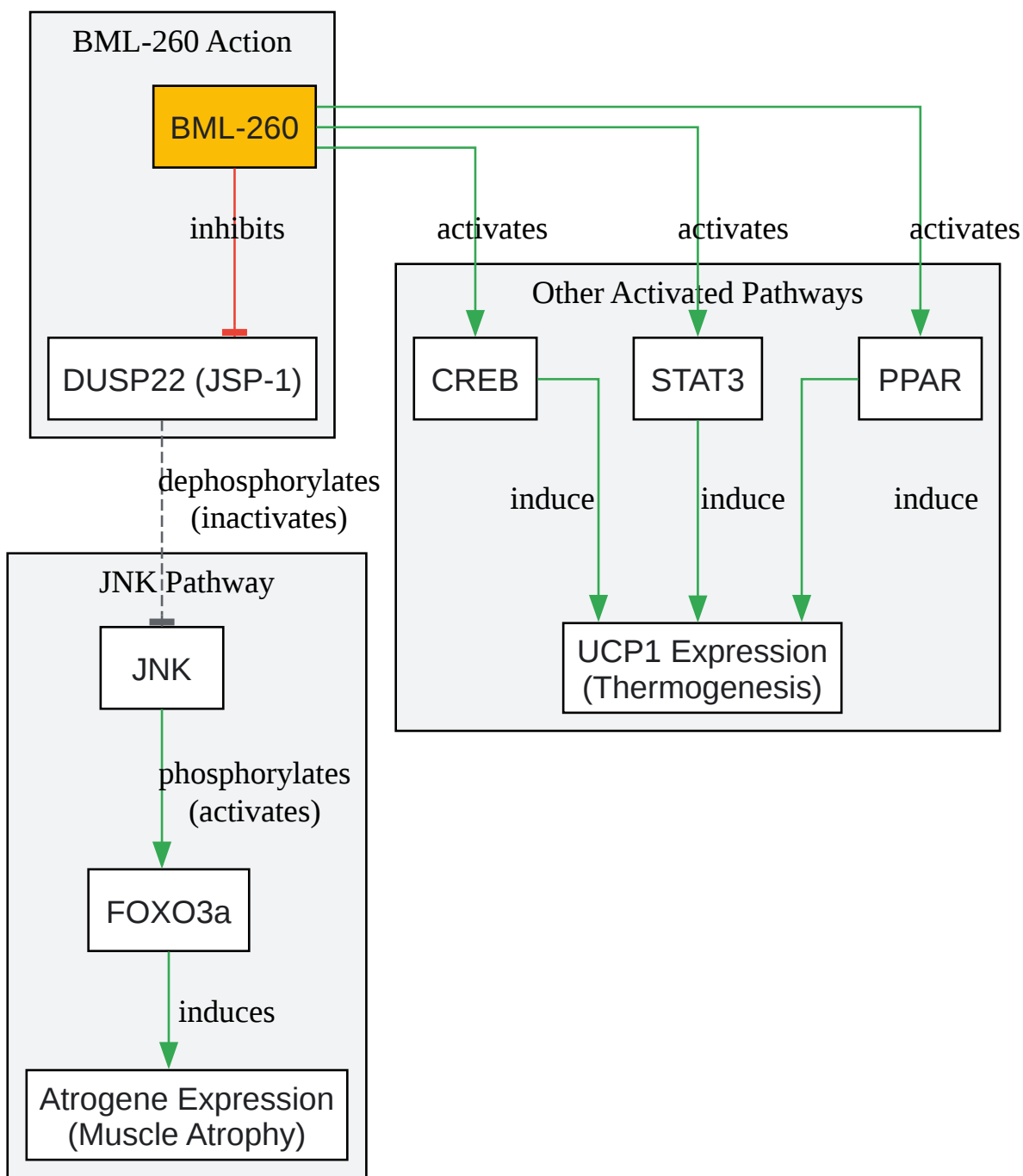

[Click to download full resolution via product page](#)

Caption: **BML-260** inhibits DUSP22, leading to modulation of the JNK pathway and activation of other signaling cascades.

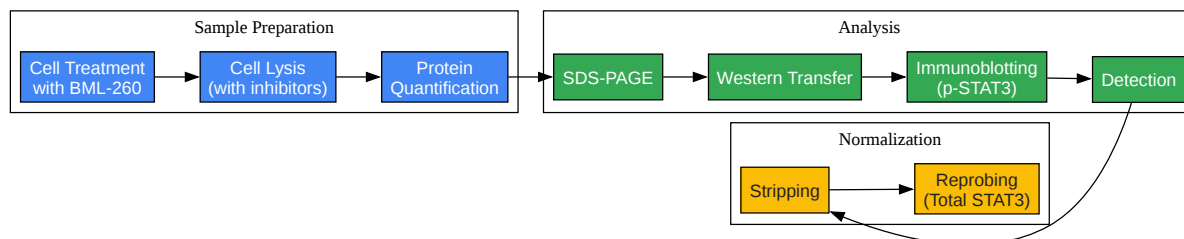

[Click to download full resolution via product page](#)

Caption: A typical experimental workflow for analyzing protein phosphorylation changes induced by **BML-260** using Western blotting.

Need Custom Synthesis?

BenchChem offers custom synthesis for rare earth carbides and specific isotopic labeling.

Email: info@benchchem.com or [Request Quote Online](#).

References

- 1. Modulating phosphatase DUSP22 with BML-260 ameliorates skeletal muscle wasting via Akt independent JNK-FOXO3a repression - PMC [[pmc.ncbi.nlm.nih.gov](https://pubmed.ncbi.nlm.nih.gov/)]
- 2. The Opportunities and Challenges of Peroxisome Proliferator-Activated Receptors Ligands in Clinical Drug Discovery and Development - PMC [[pmc.ncbi.nlm.nih.gov](https://pubmed.ncbi.nlm.nih.gov/)]
- 3. [medchemexpress.com](https://www.medchemexpress.com/) [[medchemexpress.com](https://www.medchemexpress.com/)]
- 4. [scbt.com](https://www.scbt.com/) [[scbt.com](https://www.scbt.com/)]
- 5. BML-260 | DUSP22 inhibitor | Probechem Biochemicals [[probechem.com](https://www.probechem.com/)]
- 6. Modulating phosphatase DUSP22 with BML-260 ameliorates skeletal muscle wasting via Akt independent JNK-FOXO3a repression | EMBO Molecular Medicine [[link.springer.com](https://www.embo-molmed.org/)]
- 7. Modulating phosphatase DUSP22 with BML-260 ameliorates skeletal muscle wasting via Akt independent JNK-FOXO3a repression - PubMed [pubmed.ncbi.nlm.nih.gov]

- [8. BML-260|CAS 862827-45-0|DC Chemicals \[dcchemicals.com\]](#)
- To cite this document: BenchChem. [Technical Support Center: BML-260 Experimental Design and Troubleshooting]. BenchChem, [2026]. [Online PDF]. Available at: [<https://www.benchchem.com/product/b15614266/docs#technical-support-center-bml-260-experimental-design-and-troubleshooting>]

Disclaimer & Data Validity:

The information provided in this document is for Research Use Only (RUO) and is strictly not intended for diagnostic or therapeutic procedures. While BenchChem strives to provide accurate protocols, we make no warranties, express or implied, regarding the fitness of this product for every specific experimental setup.

Technical Support: The protocols provided are for reference purposes. Unsure if this reagent suits your experiment?

Need Industrial/Bulk Grade? [Request Custom Synthesis Quote](#)

BenchChem

Our mission is to be the trusted global source of essential and advanced chemicals, empowering scientists and researchers to drive progress in science and industry.

Contact

Address: 3281 E Guasti Rd
Ontario, CA 91761, United States
Phone: (601) 213-4426
Email: info@benchchem.com

[Contact our Ph.D. Support Team for a compatibility check](#)