

Technical Support Center: Addressing Off-Target Effects of HER2-Targeted Immunotherapy

Author: BenchChem Technical Support Team. **Date:** April 2026

Compound of Interest

Compound Name: CH401 peptide

Cat. No.: B15614319

[Get Quote](#)

This technical support center provides researchers, scientists, and drug development professionals with troubleshooting guides and frequently asked questions (FAQs) to address specific issues encountered during experiments involving HER2-targeted immunotherapies.

Frequently Asked Questions (FAQs)

Q1: What are "on-target, off-tumor" effects in the context of HER2-targeted immunotherapy?

A: "On-target, off-tumor" effects refer to the unintended activity of HER2-targeted immunotherapies against healthy tissues that express low levels of the HER2 protein. While HER2 is overexpressed in many cancers, it is also present on the cell membranes of various normal epithelial cells, including those in the gastrointestinal, respiratory, reproductive, and urinary tracts, as well as the skin.[1] This can lead to toxicities when the immunotherapy, such as CAR T-cells, recognizes and attacks these healthy tissues.

Q2: How can I distinguish between on-target, off-tumor toxicity and non-specific cytotoxicity in my in vitro experiments?

A: To differentiate between these two effects, it is crucial to include proper controls in your experimental setup.

- **HER2-Negative Control Cells:** Use a cell line that does not express HER2. If you observe cytotoxicity against these cells, it is likely non-specific.
- **Competitive Inhibition:** Pre-incubate your HER2-positive target cells with a blocking antibody that binds to HER2 but does not elicit an immune response. A reduction in cytotoxicity in the presence of the blocking antibody suggests the effect is HER2-specific.
- **Effector Cell Controls:** Include effector cells (e.g., untransduced T-cells) that do not express the HER2-targeting receptor. This will help identify any baseline cytotoxicity from the effector cells themselves.

Q3: What are the common causes of high background cytokine levels in an in vitro cytokine release assay (CRA)?

A: High background in a CRA can obscure the specific response to your therapeutic agent.

Common causes include:

- **Endotoxin (LPS) Contamination:** Endotoxins from bacteria are potent stimulators of immune cells and can lead to high cytokine production. Ensure all reagents, media, and labware are endotoxin-free.[2]
- **Cell Activation During Isolation:** The process of isolating peripheral blood mononuclear cells (PBMCs) can sometimes activate them. Handle cells gently and allow them to rest in culture for a period before starting the assay.
- **Serum Components:** Some components in fetal bovine serum (FBS) can be immunogenic. It is advisable to pre-screen different lots of FBS for low background cytokine induction.
- **High Cell Density:** Plating cells at too high a density can lead to spontaneous activation and cytokine release. Optimize the cell seeding density for your specific assay.

Q4: Why am I observing toxicity in my healthy tissue control cells even though they are reported to have low HER2 expression?

A: Several factors could contribute to this observation:

- **High Sensitivity of the Immunotherapy:** Some immunotherapies, particularly high-affinity CAR T-cells, can be activated by very low densities of the target antigen, leading to the killing of cells with basal HER2 expression.
- **Variability in HER2 Expression:** HER2 expression can vary between different sources of primary cells and can also be influenced by cell culture conditions. It is advisable to quantify HER2 expression on your specific control cells using methods like flow cytometry or immunohistochemistry (IHC).
- **Upregulation of HER2 in Culture:** Certain culture conditions can lead to an upregulation of HER2 expression on normal cells over time.

Troubleshooting Guides

Guide 1: Unexpected Cytotoxicity Results

Q: My HER2-targeted immunotherapy is showing significant cytotoxicity against my HER2-negative control cell line. What should I do?

A: This suggests a non-specific cytotoxic effect. Here are the steps to troubleshoot this issue:

- **Confirm HER2 Status:** Re-verify the HER2 expression of your negative control cell line using a reliable method like flow cytometry or Western blot.
- **Evaluate Effector Cell Health:** Assess the viability and activation status of your effector cells. Highly activated or stressed effector cells may exhibit non-specific killing.
- **Check for Contamination:** Test your cell cultures for mycoplasma or other contaminants that could be inducing a general immune response.
- **Perform a Titration:** Titrate the effector-to-target (E:T) ratio. Non-specific killing may be more pronounced at very high E:T ratios.
- **Use a Different Negative Control:** Test a different, well-characterized HER2-negative cell line to see if the issue persists.

Guide 2: Inconsistent Results in Cytokine Release Assays (CRAs)

Q: I am observing high variability in cytokine levels between replicate wells in my CRA. What are the potential causes and solutions?

A: High variability can compromise the reliability of your data. Consider the following:

- **Uneven Cell Seeding:** Ensure a homogenous single-cell suspension before plating to avoid clumps and ensure an equal number of cells per well.
- **Pipetting Errors:** Use calibrated pipettes and be consistent with your pipetting technique, especially when adding small volumes of stimulating agents or cells.
- **Edge Effects:** The outer wells of a 96-well plate are prone to evaporation. To mitigate this, avoid using the outer wells for experimental samples and instead fill them with sterile PBS or media.
- **Inconsistent Incubation Conditions:** Ensure uniform temperature and CO₂ distribution within your incubator.

Data Presentation

Table 1: Relative HER2 Expression in Normal Tissues and Cancer Cell Lines

This table summarizes the typical HER2 expression levels across various human tissues and cell lines, as determined by immunohistochemistry (IHC). The IHC scoring system is a semi-quantitative measure of protein expression.

Tissue/Cell Line	Type	Typical HER2 IHC Score	Reference
Normal Tissues			
Breast	Normal Epithelium	0 to 1+ (low but detectable)	[3]
Gastrointestinal Tract	Epithelial Cells	0 to 1+ (faint)	[1]
Respiratory Tract	Epithelial Cells	0 to 1+ (faint)	[1]
Skin	Epithelial Cells	0 to 1+ (faint)	[1]
Placenta	Syncytiotrophoblasts	1+ to 2+ (weak to moderate)	[4]
Cancer Cell Lines			
SK-BR-3	Breast Carcinoma	3+ (high)	[5]
BT-474	Breast Carcinoma	3+ (high)	[5]
MDA-MB-468	Breast Carcinoma	0 (negative)	[2]
MCF7	Breast Carcinoma	0 to 1+ (low)	[1]
NCI-N87	Gastric Carcinoma	3+ (high)	
SKOV-3	Ovarian Carcinoma	3+ (high)	[1]
Calu-3	Lung Adenocarcinoma	2+ to 3+ (moderate to high)	

IHC Score Interpretation: 0/1+ = Negative/Low, 2+ = Equivocal, 3+ = Positive/High Overexpression.

Experimental Protocols

Protocol 1: Chromium-51 (⁵¹Cr) Release Cytotoxicity Assay

This assay measures the release of radioactive ^{51}Cr from pre-labeled target cells upon lysis by effector cells, which is a direct measure of cytotoxicity.

Materials:

- Target cells (HER2-positive and HER2-negative)
- Effector cells (e.g., HER2-CAR T-cells)
- Complete culture medium (e.g., R-10)
- Fetal Bovine Serum (FBS)
- ^{51}Cr -sodium chromate
- 96-well U-bottom plates
- Lysis buffer (e.g., 2.5% Triton X-100)
- Scintillation counter and plates (e.g., LumaPlate)

Procedure:

- Target Cell Labeling: a. Resuspend $1-5 \times 10^6$ target cells in 100 μL of FBS. b. Add 100 μCi of ^{51}Cr and incubate for 1-2 hours at 37°C , mixing gently every 30 minutes. c. Wash the labeled cells three times with 10 mL of complete medium to remove unincorporated ^{51}Cr . d. Resuspend the cells in complete medium at a concentration of 1×10^5 cells/mL.
- Assay Setup: a. Plate 100 μL of the labeled target cell suspension into each well of a 96-well U-bottom plate (10,000 cells/well). b. Prepare serial dilutions of your effector cells to achieve the desired Effector:Target (E:T) ratios (e.g., 40:1, 20:1, 10:1, 5:1). c. Add 100 μL of the effector cell suspensions to the wells containing target cells.
- Controls:
 - Spontaneous Release: Target cells + 100 μL of medium only.
 - Maximum Release: Target cells + 100 μL of lysis buffer.

- Incubation: a. Centrifuge the plate at 200 x g for 3 minutes to pellet the cells. b. Incubate the plate for 4-6 hours at 37°C in a 5% CO₂ incubator.
- Measurement: a. Centrifuge the plate at 500 x g for 5 minutes. b. Carefully transfer 50-100 µL of the supernatant from each well to a scintillation plate. c. Measure the radioactivity (counts per minute, CPM) using a scintillation counter.
- Calculation:
 - % Specific Lysis = [(Experimental Release - Spontaneous Release) / (Maximum Release - Spontaneous Release)] x 100

Protocol 2: Lactate Dehydrogenase (LDH) Cytotoxicity Assay

This colorimetric assay quantifies the activity of LDH, a stable cytosolic enzyme that is released into the culture medium upon cell lysis.

Materials:

- Target and effector cells
- Complete culture medium (serum-free or low-serum is recommended to reduce background)
- 96-well flat-bottom plates
- LDH cytotoxicity assay kit (containing substrate, cofactor, and dye)
- Lysis buffer (provided with the kit)
- Stop solution (provided with the kit)
- Microplate reader

Procedure:

- Assay Setup: a. Plate target cells in a 96-well plate and allow them to adhere overnight if necessary. b. Add effector cells at the desired E:T ratios.

- Controls:
 - Spontaneous LDH Release (Target Control): Target cells + medium.
 - Maximum LDH Release (Target Control): Target cells + lysis buffer.
 - Medium Background Control: Medium only.
 - Effector Cell Control: Effector cells + medium.
- Incubation: a. Incubate the plate for the desired duration (e.g., 4, 12, or 24 hours) at 37°C. b. 45 minutes before the end of the incubation, add 10 µL of lysis buffer to the maximum release wells.
- Measurement: a. Centrifuge the plate at 250 x g for 10 minutes. b. Transfer 50 µL of supernatant from each well to a new 96-well flat-bottom plate. c. Prepare the LDH reaction mixture according to the kit manufacturer's instructions. d. Add 50 µL of the reaction mixture to each well containing the supernatant. e. Incubate at room temperature for 30 minutes, protected from light. f. Add 50 µL of stop solution to each well. g. Measure the absorbance at 490 nm using a microplate reader.
- Calculation: a. Subtract the absorbance of the medium background control from all other readings. b. % Cytotoxicity = $[(\text{Experimental Value} - \text{Effector Cell Control} - \text{Spontaneous Release}) / (\text{Maximum Release} - \text{Spontaneous Release})] \times 100$

Mandatory Visualization

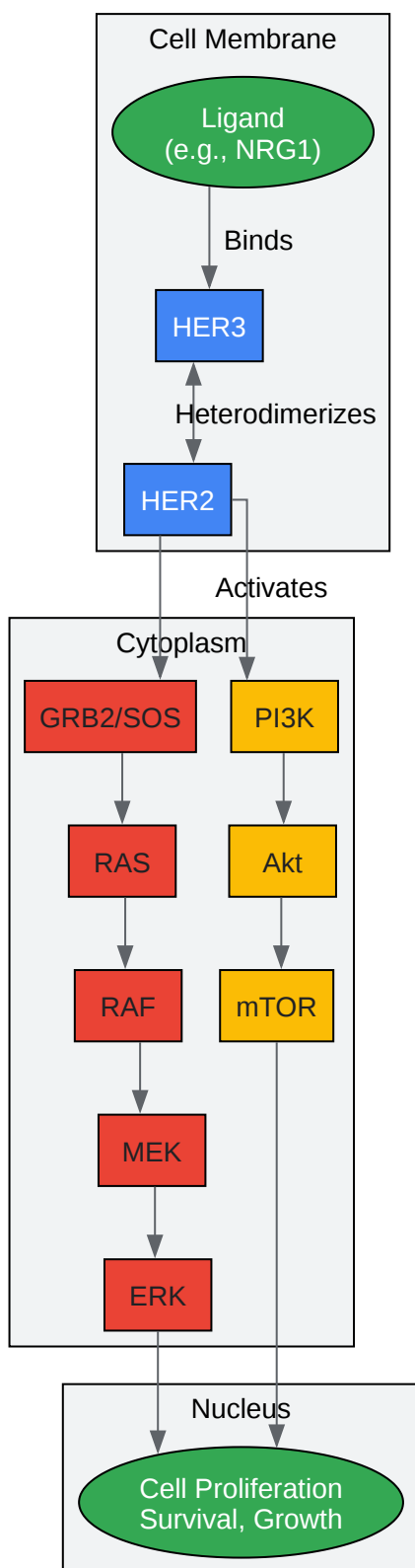

[Click to download full resolution via product page](#)

Caption: HER2 Signaling Pathway.

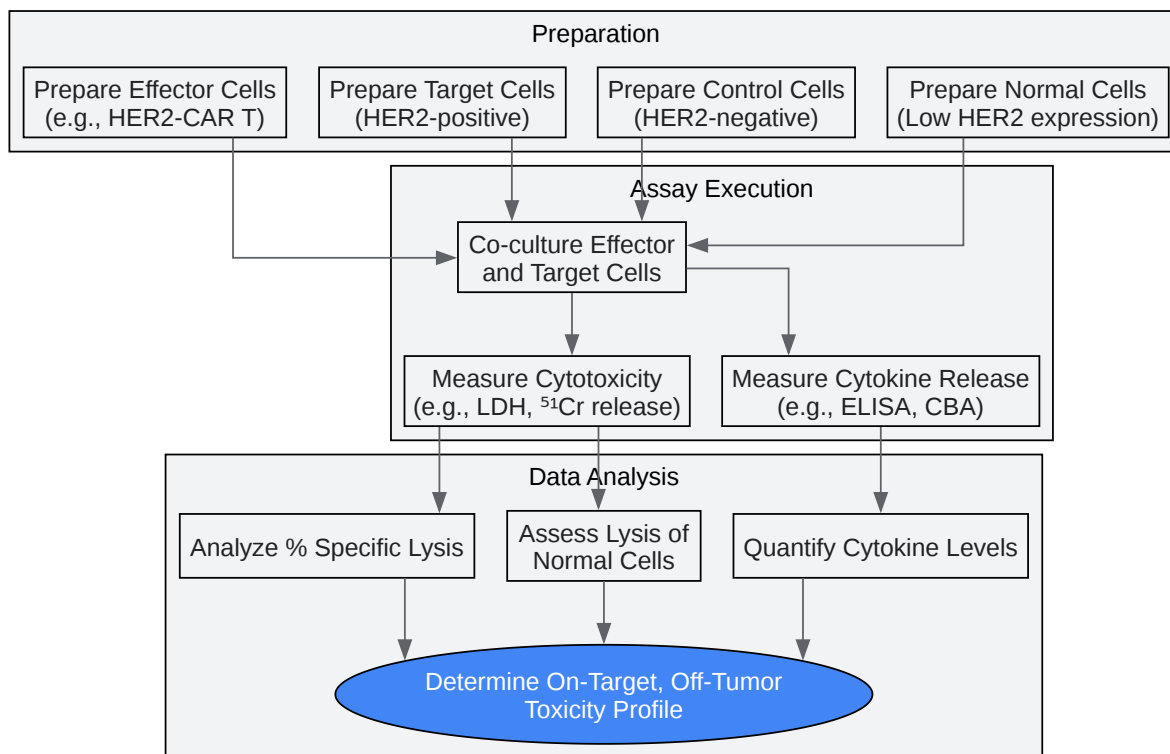

[Click to download full resolution via product page](#)

Caption: Experimental Workflow for Assessing Off-Target Effects.

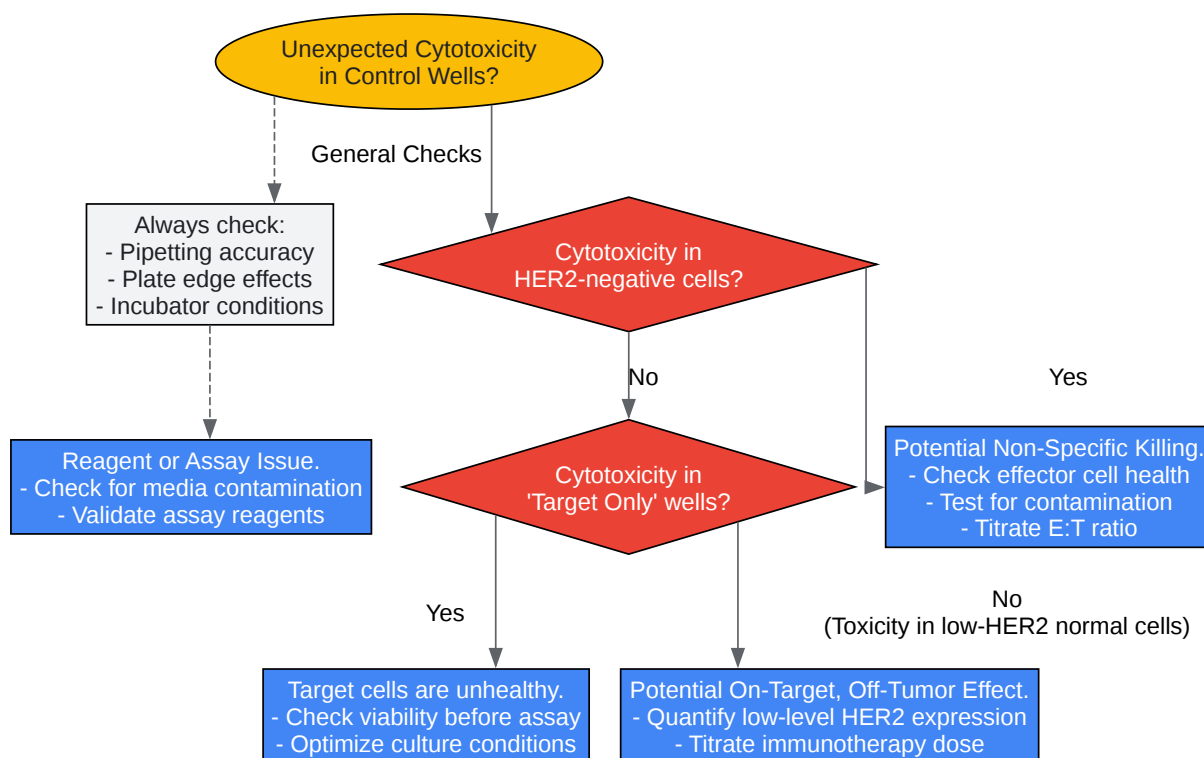

[Click to download full resolution via product page](#)

Caption: Troubleshooting Decision Tree for Unexpected Cytotoxicity.

Need Custom Synthesis?

BenchChem offers custom synthesis for rare earth carbides and specific isotopic labeling.

Email: info@benchchem.com or [Request Quote Online](#).

References

- 1. aacrjournals.org [aacrjournals.org]
- 2. Pathology & Oncology Research | HER2 expression in different cell lines at different inoculation sites assessed by [52Mn]Mn-DOTAGA(anhydride)-trastuzumab [por-journal.com]
- 3. aacrjournals.org [aacrjournals.org]
- 4. ms-validatedantibodies.com [ms-validatedantibodies.com]
- 5. researchgate.net [researchgate.net]
- To cite this document: BenchChem. [Technical Support Center: Addressing Off-Target Effects of HER2-Targeted Immunotherapy]. BenchChem, [2026]. [Online PDF]. Available at: [<https://www.benchchem.com/product/b15614319/docs#technical-support-center-addressing-off-target-effects-of-her2-targeted-immunotherapy>]

Disclaimer & Data Validity:

The information provided in this document is for Research Use Only (RUO) and is strictly not intended for diagnostic or therapeutic procedures. While BenchChem strives to provide accurate protocols, we make no warranties, express or implied, regarding the fitness of this product for every specific experimental setup.

Technical Support: The protocols provided are for reference purposes. Unsure if this reagent suits your experiment?

Need Industrial/Bulk Grade? [Request Custom Synthesis Quote](#)

BenchChem

Our mission is to be the trusted global source of essential and advanced chemicals, empowering scientists and researchers to drive progress in science and industry.

Contact

Address: 3281 E Guasti Rd
Ontario, CA 91761, United States
Phone: (601) 213-4426
Email: info@benchchem.com

Contact our Ph.D. Support Team for a compatibility check