

Preventing LEI-106 degradation in solution

Author: BenchChem Technical Support Team. **Date:** April 2026

Compound of Interest

Compound Name: LEI-106

Cat. No.: B15614893

[Get Quote](#)

Technical Support Center: LEI-106

Disclaimer: The following information is provided as a general guide for researchers working with the novel small molecule **LEI-106**. As a newly characterized compound, publicly available stability and handling data are limited. This guide is based on established best practices for small molecule inhibitors. Researchers should always refer to the specific lot's certificate of analysis and any accompanying documentation for the most accurate information.

Frequently Asked Questions (FAQs)

Q1: What are the recommended storage conditions for **LEI-106**?

A1: For optimal stability, solid **LEI-106** should be stored at -20°C, protected from light and moisture. Stock solutions of **LEI-106** in anhydrous DMSO can also be stored at -20°C for up to one month. For long-term storage of solutions, it is recommended to store them at -80°C.^[1] To prevent degradation from repeated freeze-thaw cycles, we recommend aliquoting the stock solution into single-use volumes.^[1]

Q2: My **LEI-106** precipitated out of the aqueous buffer after diluting it from a DMSO stock. What should I do?

A2: Precipitation upon dilution into an aqueous buffer is a common issue with hydrophobic small molecules.^[2] Here are some troubleshooting steps:

- Decrease the final concentration: The concentration of **LEI-106** may have surpassed its solubility limit in the aqueous buffer.
- Optimize DMSO concentration: While minimizing DMSO is ideal, a slightly higher final concentration (e.g., up to 0.5%) might be necessary to maintain solubility. Always include a vehicle control with the same final DMSO concentration in your experiments.^[2]
- Adjust buffer pH: The solubility of ionizable compounds can be pH-dependent.^[3] Experimenting with different pH values for your buffer may improve solubility.
- Use a different solvent system: Consider using a co-solvent or a formulation with solubility-enhancing excipients if precipitation persists.^[2]

Q3: I suspect that **LEI-106** is degrading in my cell culture medium during a long-term experiment. How can I check for this?

A3: To confirm suspected degradation in your assay medium, you can perform a time-course experiment.^[2] Measure the biological activity of **LEI-106** at various time points after its addition to the medium. A significant decrease in activity over time could indicate instability. Additionally, analytical techniques like High-Performance Liquid Chromatography (HPLC) can be used to assess the purity of the compound over time and detect the appearance of degradation products.^[1]

Q4: Can I warm my **LEI-106** solution to help it dissolve?

A4: Gentle warming can be used to aid in the dissolution of **LEI-106**, provided that the compound's stability at elevated temperatures is not compromised.^[1] It is recommended to warm the solution briefly and vortex thoroughly. If precipitation persists, centrifuge the vial and use the supernatant after re-quantifying the concentration.^[1]

Troubleshooting Guide

Issue	Potential Cause	Recommended Solution
Inconsistent experimental results between aliquots	Incomplete initial dissolution of the stock solution.	Ensure the compound is fully dissolved by vortexing and visual inspection before making aliquots.[1]
Uneven aliquoting.	Use calibrated pipettes for accurate and consistent aliquoting.[1]	
Degradation of some aliquots due to improper storage.	Review storage and handling procedures to ensure all aliquots are treated consistently.[1]	
Loss of biological activity in the assay	Degradation of LEI-106 during storage or handling.	Perform an analytical check (e.g., HPLC) to confirm the purity and concentration. If degradation is confirmed, use a fresh stock.[1]
Adsorption of LEI-106 to container surfaces.	Consider using low-adhesion microcentrifuge tubes to minimize adsorption.[1]	
Precipitation in aqueous buffer	Exceeded aqueous solubility limit.	Decrease the final concentration of LEI-106.[2]
Insufficient organic solvent.	Optimize the final DMSO concentration (ensure appropriate vehicle controls are included).[2]	

Experimental Protocols

Protocol 1: Preparation of LEI-106 Stock Solution

- Materials:
 - **LEI-106** (solid)

- Anhydrous Dimethyl Sulfoxide (DMSO)
- Sterile, low-adhesion microcentrifuge tubes
- Procedure:
 1. Allow the vial of solid **LEI-106** to equilibrate to room temperature before opening to prevent moisture condensation.
 2. Add the appropriate volume of anhydrous DMSO to the vial to achieve the desired stock concentration (e.g., 10 mM).
 3. Vortex the solution for 1-2 minutes to ensure complete dissolution. Gentle warming can be applied if necessary.
 4. Visually inspect the solution to confirm that no solid particles remain.
 5. Aliquot the stock solution into single-use volumes in sterile, low-adhesion microcentrifuge tubes.
 6. Store the aliquots at -80°C for long-term storage or -20°C for short-term storage (up to one month).

Protocol 2: Aqueous Solubility Assessment

- Materials:
 - **LEI-106** DMSO stock solution (e.g., 10 mM)
 - Aqueous buffer of choice (e.g., PBS, pH 7.4)
 - 96-well clear bottom plate
 - Plate reader
- Procedure:
 1. Prepare a serial dilution of the **LEI-106** DMSO stock in DMSO.

2. In the 96-well plate, add the aqueous buffer to each well.
3. Add a small, consistent volume of each **LEI-106** dilution (and a DMSO-only control) to the wells, ensuring the final DMSO concentration is kept constant and below a level that affects the assay (e.g., <0.5%).
4. Incubate the plate at room temperature for 1-2 hours with gentle shaking.[2]
5. Visually inspect each well for any signs of precipitation.
6. (Optional) Quantify precipitation by measuring the turbidity using a plate reader at a wavelength where the compound does not absorb (e.g., 600 nm).[2]

Visualizations

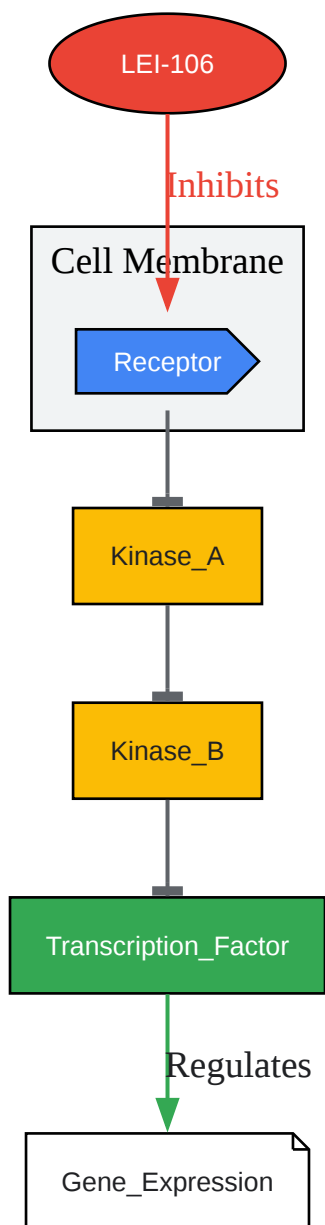

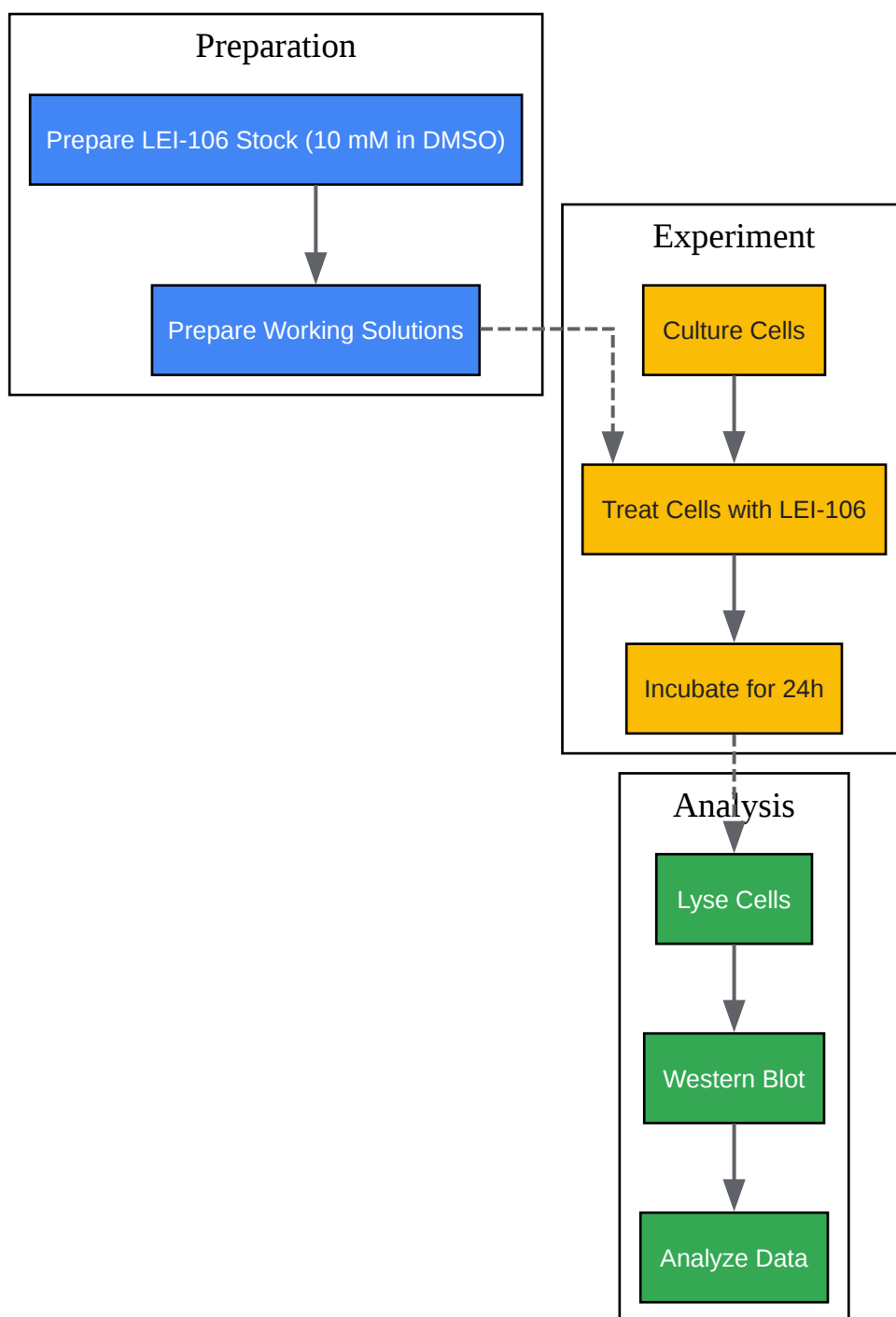

[Click to download full resolution via product page](#)

Need Custom Synthesis?

BenchChem offers custom synthesis for rare earth carbides and specific isotopic labeling.

Email: info@benchchem.com or [Request Quote Online](#).

References

- [1. benchchem.com \[benchchem.com\]](#)
- [2. benchchem.com \[benchchem.com\]](#)
- [3. How to Improve Drug Plasma Stability? - Creative Bioarray | Creative Bioarray \[creative-bioarray.com\]](#)
- To cite this document: BenchChem. [Preventing LEI-106 degradation in solution]. BenchChem, [2026]. [Online PDF]. Available at: [\[https://www.benchchem.com/product/b15614893/docs#preventing-lei-106-degradation-in-solution\]](https://www.benchchem.com/product/b15614893/docs#preventing-lei-106-degradation-in-solution)

Disclaimer & Data Validity:

The information provided in this document is for Research Use Only (RUO) and is strictly not intended for diagnostic or therapeutic procedures. While BenchChem strives to provide accurate protocols, we make no warranties, express or implied, regarding the fitness of this product for every specific experimental setup.

Technical Support: The protocols provided are for reference purposes. Unsure if this reagent suits your experiment?

Need Industrial/Bulk Grade? [Request Custom Synthesis Quote](#)

BenchChem

Our mission is to be the trusted global source of essential and advanced chemicals, empowering scientists and researchers to drive progress in science and industry.

Contact

Address: 3281 E Guasti Rd

Ontario, CA 91761, United States

Phone: (601) 213-4426

Email: info@benchchem.com

Contact our Ph.D. Support Team for a compatibility check