

Application Notes and Protocols for SR-3306 in Primary Neuron Cultures

Author: BenchChem Technical Support Team. **Date:** April 2026

Compound of Interest

Compound Name: SR-3306
Cat. No.: B15614979

[Get Quote](#)

Audience: Researchers, scientists, and drug development professionals.

Introduction **SR-3306** is a potent, selective, and brain-penetrant small molecule inhibitor of c-jun-N-terminal kinase (JNK).[1][2][3] The JNK signaling pathway is a critical mediator of neuronal apoptosis in response to various stressors and has been implicated in the pathophysiology of neurodegenerative disorders such as Parkinson's disease (PD).[2] **SR-3306** has demonstrated significant neuroprotective effects in both in vitro primary neuron cultures and in vivo animal models of Parkinson's disease.[1][2][4] These notes provide detailed protocols for utilizing **SR-3306** to investigate its neuroprotective capabilities in primary neuron cultures.

Mechanism of Action **SR-3306** exerts its neuroprotective effects by directly inhibiting the JNK enzyme.[2] In models of neuronal stress, such as exposure to the neurotoxin 1-methyl-4-phenylpyridinium (MPP+), the JNK pathway is activated. This leads to the phosphorylation of the transcription factor c-jun.[1] Phosphorylated c-jun (p-c-jun) then promotes the expression of pro-apoptotic genes, ultimately leading to neuronal cell death. By inhibiting JNK, **SR-3306** prevents the phosphorylation of c-jun, thereby blocking the downstream apoptotic cascade and preserving neuronal viability.[1] A dose-dependent inhibition of c-jun phosphorylation by **SR-3306** serves as a key biomarker for demonstrating its on-target activity.[1]

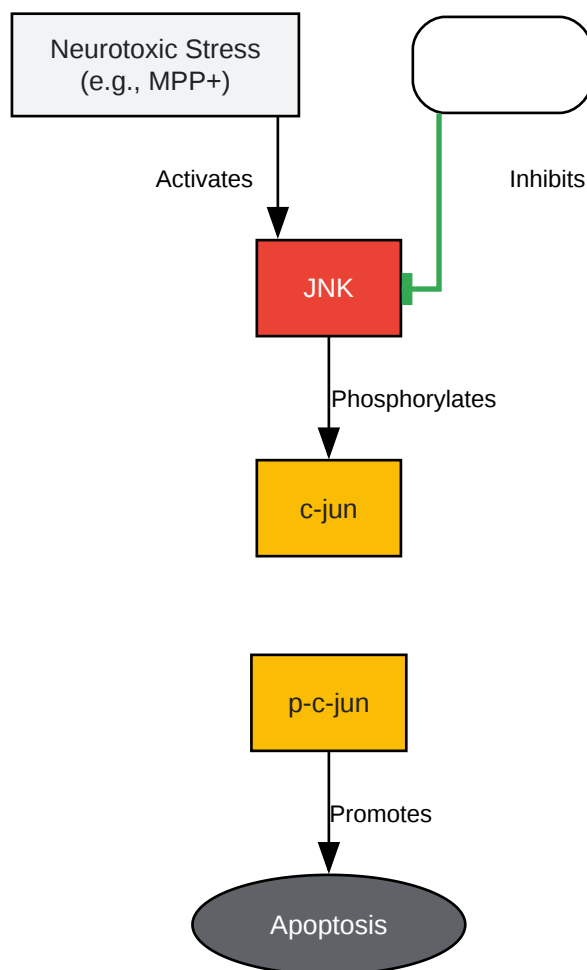

[Click to download full resolution via product page](#)

Caption: JNK signaling pathway and the inhibitory action of **SR-3306**.

Data Presentation

Table 1: In Vitro Efficacy of **SR-3306** in Primary Dopaminergic Neurons

This table summarizes the neuroprotective effects of **SR-3306** against MPP+-induced toxicity in primary mesencephalic dopaminergic neuron cultures.

Parameter	Value	Condition	Source
Toxin	10 μ M MPP+	Reduces TH+ neurons by ~50%	[1]
SR-3306 Treatment	10 - 1000 nM	Co-treatment with MPP+	[1]
Effective Concentration	300 - 1000 nM	Statistically significant protection (p < 0.01)	[1]
Neuroprotection	> 90%	Achieved at 300 nM and 1000 nM	[1][2]
Cell-based IC ₅₀	~230 nM	Inhibition of c-jun phosphorylation	[1]
Compound Toxicity	No effect	1000 nM SR-3306 alone vs. control	[1]

Table 2: In Vivo Efficacy and Brain Exposure of SR-3306

This table presents data from animal models of Parkinson's disease, demonstrating the bioavailability and neuroprotective action of **SR-3306** in vivo.

Model	Administration	Key Findings	Source
MPTP Mouse Model	30 mg/kg, oral	Increased surviving TH+ neurons to 72% of control.	[1]
MPTP Mouse Model	20 & 30 mg/kg, oral	Dose-dependent reduction in p-c-jun levels.	[1]
6-OHDA Rat Model	10 mg/kg/day, s.c.	6-fold increase in surviving TH+ neurons in the SNpc.	[4]
6-OHDA Rat Model	10 mg/kg/day, s.c.	2.3-fold reduction in p-c-jun immunoreactive neurons.	[3][4]
Pharmacokinetics	10 mg/kg/day, s.c. (14 days)	Steady-state brain concentration of 347 nM.	[3][4]
Pharmacokinetics	Single oral dose	Brain concentration remained above cell-based IC ₅₀ for >8 hours.	[1]

Experimental Protocols

Protocol 1: Primary Mesencephalic Neuron Culture

This protocol is adapted from standard procedures for primary neuron isolation and is suitable for studying the effects of **SR-3306** on dopaminergic neurons.[5][6]

Materials:

- E14-E16 timed-pregnant mice or rats
- Hibernate-E medium

- Papain (2 mg/mL)
- Neurobasal Plus Medium supplemented with B-27 Plus and GlutaMAX
- Poly-D-Lysine (50 µg/mL)
- Sterile dissection tools, conical tubes, and pipettes

Procedure:

- **Plate Coating:** Coat culture vessels (e.g., 48-well plates) with 50 µg/mL Poly-D-Lysine solution for at least 1 hour at room temperature. Rinse three times with sterile water and allow to dry completely in a laminar flow hood.[6]
- **Dissection:** Sacrifice pregnant dam according to approved institutional guidelines. Dissect embryos and isolate the ventral mesencephalon (midbrain) containing the substantia nigra in ice-cold Hibernate-E medium.
- **Digestion:** Transfer the tissue to a sterile tube containing 4 mL of Hibernate-E with 2 mg/mL papain. Incubate for 30 minutes at 30°C, gently mixing every 5 minutes.[6]
- **Dissociation:** Stop the digestion by adding 6 mL of complete Hibernate-E medium and centrifuge for 5 minutes at 150 x g. Resuspend the tissue pellet in 5 mL of complete Neurobasal Plus medium. Gently triturate with a fire-polished Pasteur pipette until the tissue is fully dissociated and the solution appears cloudy.[5][6]
- **Plating:** Determine cell density using a hemacytometer. Plate neurons at a density of approximately 1×10^5 cells/well in a 48-well plate.[6]
- **Culture Maintenance:** Incubate at 37°C in a humidified 5% CO₂ atmosphere. Perform a half-medium change every 3-4 days. Cultures are typically ready for experimental use after 5-7 days in vitro.

Protocol 2: MPP+ Neuroprotection Assay

This protocol details how to assess the neuroprotective effect of **SR-3306** against MPP+-induced toxicity.

Materials:

- Mature primary mesencephalic neuron cultures (from Protocol 1)
- **SR-3306** stock solution (in DMSO)
- MPP+ iodide stock solution (in water)
- Complete Neurobasal Plus medium
- Fixative (4% Paraformaldehyde)
- Antibodies: anti-Tyrosine Hydroxylase (TH) primary, appropriate fluorescent secondary
- DAPI nuclear stain

Procedure:

- Pre-treatment: Prepare serial dilutions of **SR-3306** (e.g., 10 nM to 1000 nM) in complete culture medium. Add the **SR-3306** solutions to the appropriate wells. Include a vehicle control (DMSO at the same final concentration).
- Toxin Treatment: After 30-60 minutes of pre-treatment with **SR-3306**, add MPP+ to a final concentration of 10 μ M to all wells except the untreated control group.[\[1\]](#)
- Incubation: Return the plate to the incubator and incubate for 24-48 hours.
- Immunocytochemistry:
 - Fix the cells with 4% paraformaldehyde for 15 minutes.
 - Wash three times with PBS.
 - Permeabilize and block with a solution containing 0.1% Triton X-100 and 5% goat serum for 1 hour.
 - Incubate with primary antibody against Tyrosine Hydroxylase (TH) overnight at 4°C to specifically label dopaminergic neurons.

- Wash and incubate with a fluorescently-labeled secondary antibody and DAPI for 1-2 hours.
- Analysis: Acquire images using a fluorescence microscope. Quantify the number of surviving TH-positive neurons in each treatment group.[1] Express the data as a percentage of the untreated control group.

Protocol 3: Assessment of c-jun Phosphorylation by Western Blot

This protocol is for verifying the on-target effect of **SR-3306** by measuring the levels of phosphorylated c-jun.

Materials:

- Treated primary neuron cultures
- RIPA lysis buffer with protease and phosphatase inhibitors
- BCA protein assay kit
- SDS-PAGE gels and electrophoresis equipment
- PVDF membrane and transfer system
- Antibodies: anti-p-c-jun (Ser73), anti-total c-jun, and anti- β -actin (loading control) primary antibodies; HRP-conjugated secondary antibodies.
- ECL chemiluminescence substrate

Procedure:

- Cell Lysis: After treatment, wash cells with ice-cold PBS and lyse directly in the well with RIPA buffer. Scrape the cells, collect the lysate, and centrifuge at 14,000 x g for 15 minutes at 4°C.
- Protein Quantification: Determine the protein concentration of the supernatant using a BCA assay.

- Electrophoresis: Denature 20-30 µg of protein per sample and load onto an SDS-PAGE gel. Run the gel to separate proteins by size.
- Transfer: Transfer the separated proteins to a PVDF membrane.
- Blocking & Antibody Incubation:
 - Block the membrane with 5% non-fat milk or BSA in TBST for 1 hour.
 - Incubate with the primary antibody for p-c-jun (e.g., 1:1000 dilution) overnight at 4°C.
 - Wash the membrane with TBST.
 - Incubate with an HRP-conjugated secondary antibody for 1 hour at room temperature.
- Detection: Apply ECL substrate and visualize the protein bands using a chemiluminescence imaging system.
- Analysis: Strip the membrane and re-probe for total c-jun and a loading control (e.g., β-actin). Quantify band intensities using densitometry software. Normalize p-c-jun levels to total c-jun or the loading control to determine the extent of inhibition by **SR-3306**.^[1]

Experimental Workflow

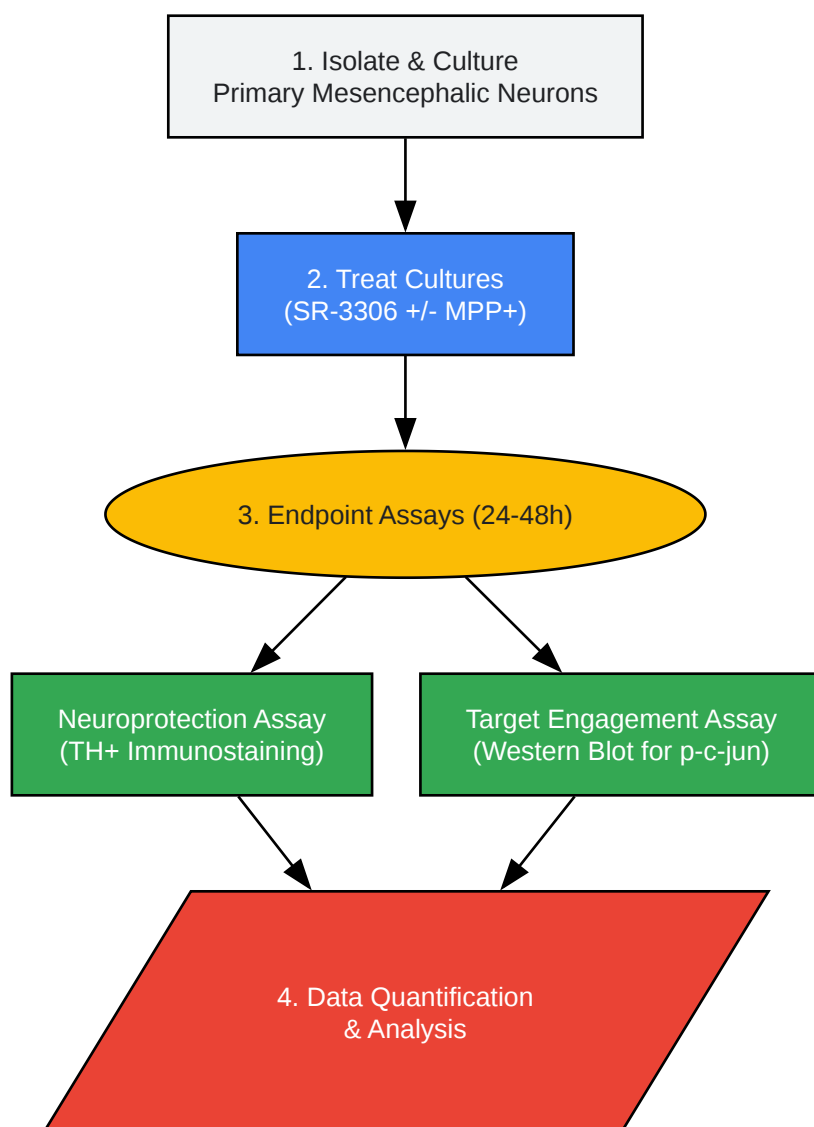

[Click to download full resolution via product page](#)

Caption: Workflow for testing **SR-3306** in primary neuron cultures.

Need Custom Synthesis?

BenchChem offers custom synthesis for rare earth carbides and specific isotopic labeling.

Email: info@benchchem.com or [Request Quote Online](#).

References

- [1. Small Molecule c-jun-N-Terminal Kinase Inhibitors Protect Dopaminergic Neurons in a Model of Parkinson's Disease - PMC \[pmc.ncbi.nlm.nih.gov\]](#)
- [2. neurosciencenews.com \[neurosciencenews.com\]](#)
- [3. medchemexpress.com \[medchemexpress.com\]](#)
- [4. JNK Inhibition Protects Dopamine Neurons and Provides Behavioral Improvement in a Rat 6-Hydroxydopamine Model of Parkinson's Disease - PMC \[pmc.ncbi.nlm.nih.gov\]](#)
- [5. Protocol for the Primary Culture of Cortical and Hippocampal neurons \[gladstone.org\]](#)
- [6. Isolation, Culture, and Characterization of Cortical and Hippocampal Neurons | Thermo Fisher Scientific - US \[thermofisher.com\]](#)
- To cite this document: BenchChem. [Application Notes and Protocols for SR-3306 in Primary Neuron Cultures]. BenchChem, [2026]. [Online PDF]. Available at: [\[https://www.benchchem.com/product/b15614979/docs#application-notes-and-protocols-for-sr-3306-in-primary-neuron-cultures\]](https://www.benchchem.com/product/b15614979/docs#application-notes-and-protocols-for-sr-3306-in-primary-neuron-cultures)

Disclaimer & Data Validity:

The information provided in this document is for Research Use Only (RUO) and is strictly not intended for diagnostic or therapeutic procedures. While BenchChem strives to provide accurate protocols, we make no warranties, express or implied, regarding the fitness of this product for every specific experimental setup.

Technical Support: The protocols provided are for reference purposes. Unsure if this reagent suits your experiment?

Need Industrial/Bulk Grade? [Request Custom Synthesis Quote](#)

BenchChem

Our mission is to be the trusted global source of essential and advanced chemicals, empowering scientists and researchers to drive progress in science and industry.

Contact

Address: 3281 E Guasti Rd

Ontario, CA 91761, United States

Phone: (601) 213-4426

Email: info@benchchem.com

Contact our Ph.D. Support Team for a compatibility check