

# Application Notes and Protocols for CMC2.24 in Cell Culture Experiments

**Author:** BenchChem Technical Support Team. **Date:** April 2026

## Compound of Interest

Compound Name: CMC2.24  
Cat. No.: B15614030

[Get Quote](#)

For Researchers, Scientists, and Drug Development Professionals

## Introduction

Chemically-Modified Curcumin 2.24 (**CMC2.24**) is a novel, synthetic analog of curcumin with enhanced stability and bioavailability.[1][2] As a pleiotropic inhibitor, **CMC2.24** has demonstrated significant anti-inflammatory, antioxidant, and anti-collagenolytic properties, making it a compound of interest for research in various diseases, including periodontitis, diabetes, and osteoarthritis.[3][4][5] These application notes provide detailed protocols for the preparation and use of **CMC2.24** in cell culture experiments, along with a summary of its known effects and signaling pathways.

## Properties and Mechanism of Action

**CMC2.24** is a triketonic phenylaminocarbonyl-curcumin derivative, a structural modification that enhances its cation-binding capacity, particularly for zinc ( $Zn^{2+}$ ), a critical cofactor for matrix metalloproteinases (MMPs).[4][6] This structural feature contributes to its potent inhibitory effects on MMPs, including MMP-2 and MMP-9.[6][7]

The primary mechanisms of action for **CMC2.24** include:

- Inhibition of Matrix Metalloproteinases (MMPs): Directly inhibits the activity of MMPs, key enzymes in extracellular matrix degradation during inflammation and tissue remodeling.[\[6\]](#)[\[7\]](#)
- Downregulation of Pro-inflammatory Cytokines: Reduces the production of key inflammatory mediators such as Interleukin-1 $\beta$  (IL-1 $\beta$ ), Interleukin-6 (IL-6), and Tumor Necrosis Factor- $\alpha$  (TNF- $\alpha$ ).[\[6\]](#)[\[8\]](#)
- Modulation of Signaling Pathways: Suppresses the activation of critical inflammatory signaling pathways, including Nuclear Factor-kappa B (NF- $\kappa$ B) and p38 Mitogen-Activated Protein Kinase (p38 MAPK).[\[3\]](#)[\[6\]](#)[\[9\]](#)

## Quantitative Data Summary

The following tables summarize the reported effects of **CMC2.24** in various experimental models.

Table 1: Inhibitory Concentrations (IC50) of **CMC2.24** against various MMPs.

Matrix Metalloproteinase (MMP)	IC50 ( $\mu$ M)	Reference
MMP-2	2-8	<a href="#">[8]</a>
MMP-9	2-8	<a href="#">[7]</a> <a href="#">[8]</a>
MMP-8	2-8	<a href="#">[8]</a>
MMP-13	2-8	<a href="#">[7]</a> <a href="#">[8]</a>

Table 2: Effects of **CMC2.24** on Inflammatory Mediators.

Mediator	Cell/Tissue Type	Treatment Concentration	Observed Effect	Reference
IL-1 $\beta$	Rat Gingival Tissue	30 mg/kg/day (in vivo)	Significant Reduction	[3]
IL-1 $\beta$	Dog Gingival Crevicular Fluid	10 mg/kg/day (in vivo)	43% Reduction	[6]
IL-6	Rat Macrophages	5 $\mu$ M	Significant Reduction	[8]
TNF- $\alpha$	Rat Gingival Tissue	30 mg/kg/day (in vivo)	Significant Reduction	[1]
Activated MMP-9	Dog Monocytes/Macrophages	ex vivo culture	Complete Block of Conversion from Pro-MMP-9	[6]
TLR-2	Dog Gingival Tissue	10 mg/kg/day (in vivo)	50.9% Reduction	[6]
p38 MAPK	Dog Gingival Tissue	10 mg/kg/day (in vivo)	37.2% Reduction	[6]

 Table 3: Cytotoxicity of **CMC2.24** in Various Cell Lines.

Cell Line	Description	Cytotoxic Concentration	Reference
Human Keratinocytes	Immortalized	> 4 $\mu$ g/mL (~10 $\mu$ M)	[6]
Human Melanocytes	Primary	> 4 $\mu$ g/mL (~10 $\mu$ M)	[6]
B16F10	Mouse Melanoma	24 and 36 $\mu$ g/mL	[6]
Rat Chondrocytes	Primary	Non-toxic at concentrations that inhibit catabolism	[5]

## Experimental Protocols

### Protocol 1: Preparation of CMC2.24 Stock Solution

Materials:

- **CMC2.24** powder
- Dimethyl sulfoxide (DMSO), cell culture grade
- Sterile microcentrifuge tubes
- Pipettes and sterile, filtered pipette tips

Procedure:

- Determine the required concentration: Based on the desired final concentration in your cell culture experiments (typically in the range of 1-10  $\mu\text{M}$ ), prepare a concentrated stock solution. A 1 mM stock solution is recommended for ease of dilution.
- Weigh the **CMC2.24** powder: In a sterile microcentrifuge tube, carefully weigh the appropriate amount of **CMC2.24** powder.
- Dissolve in DMSO: Add the calculated volume of DMSO to the tube to achieve a 1 mM stock solution. For example, to prepare 1 mL of a 1 mM stock solution of **CMC2.24** (Molecular Weight to be obtained from the supplier), dissolve the corresponding mass in 1 mL of DMSO. [3]
- Ensure complete dissolution: Vortex the solution thoroughly until the powder is completely dissolved. Gentle warming (e.g., in a 37°C water bath) may aid dissolution, but avoid excessive heat.
- Sterilization: The DMSO stock solution is considered sterile if prepared from sterile components under aseptic conditions. Filtration is generally not required and may lead to loss of compound.
- Storage: Aliquot the stock solution into smaller, single-use volumes to avoid repeated freeze-thaw cycles. Store the aliquots at -20°C or -80°C, protected from light.

## Protocol 2: Treatment of Cells with **CMC2.24**

### Materials:

- Cultured cells in appropriate multi-well plates or flasks
- Complete cell culture medium
- **CMC2.24** stock solution (from Protocol 1)
- Vehicle control (DMSO)

### Procedure:

- Cell Seeding: Seed cells at the desired density in culture vessels and allow them to adhere and stabilize overnight, or as required by the specific cell line.
- Preparation of Working Solutions:
  - Thaw an aliquot of the **CMC2.24** stock solution at room temperature.
  - Dilute the stock solution in complete cell culture medium to the desired final concentrations. It is crucial to maintain a final DMSO concentration below 0.1% (v/v) in the cell culture to avoid solvent-induced cytotoxicity.
  - Example Dilution: To achieve a final concentration of 5  $\mu\text{M}$  **CMC2.24** from a 1 mM stock, you would perform a 1:200 dilution (e.g., add 5  $\mu\text{L}$  of 1 mM stock to 995  $\mu\text{L}$  of medium).
- Vehicle Control: Prepare a vehicle control by adding the same volume of DMSO to the culture medium as used for the highest concentration of **CMC2.24**. This is essential to distinguish the effects of the compound from any effects of the solvent.
- Treatment:
  - Remove the existing medium from the cells.
  - Add the prepared media containing the different concentrations of **CMC2.24** and the vehicle control to the respective wells.

- Incubation: Incubate the cells for the desired experimental duration (e.g., 24, 48, or 72 hours) under standard cell culture conditions (e.g., 37°C, 5% CO<sub>2</sub>).
- Downstream Analysis: Following incubation, proceed with the planned experimental analysis, such as cell viability assays, protein expression analysis (Western blot), gene expression analysis (RT-qPCR), or cytokine measurements (ELISA).

## Visualizations

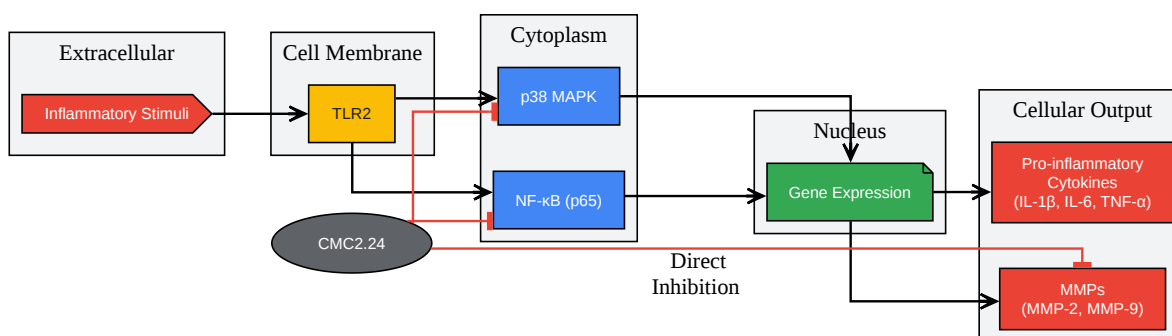

[Click to download full resolution via product page](#)

Caption: Signaling pathway modulated by **CMC2.24**.

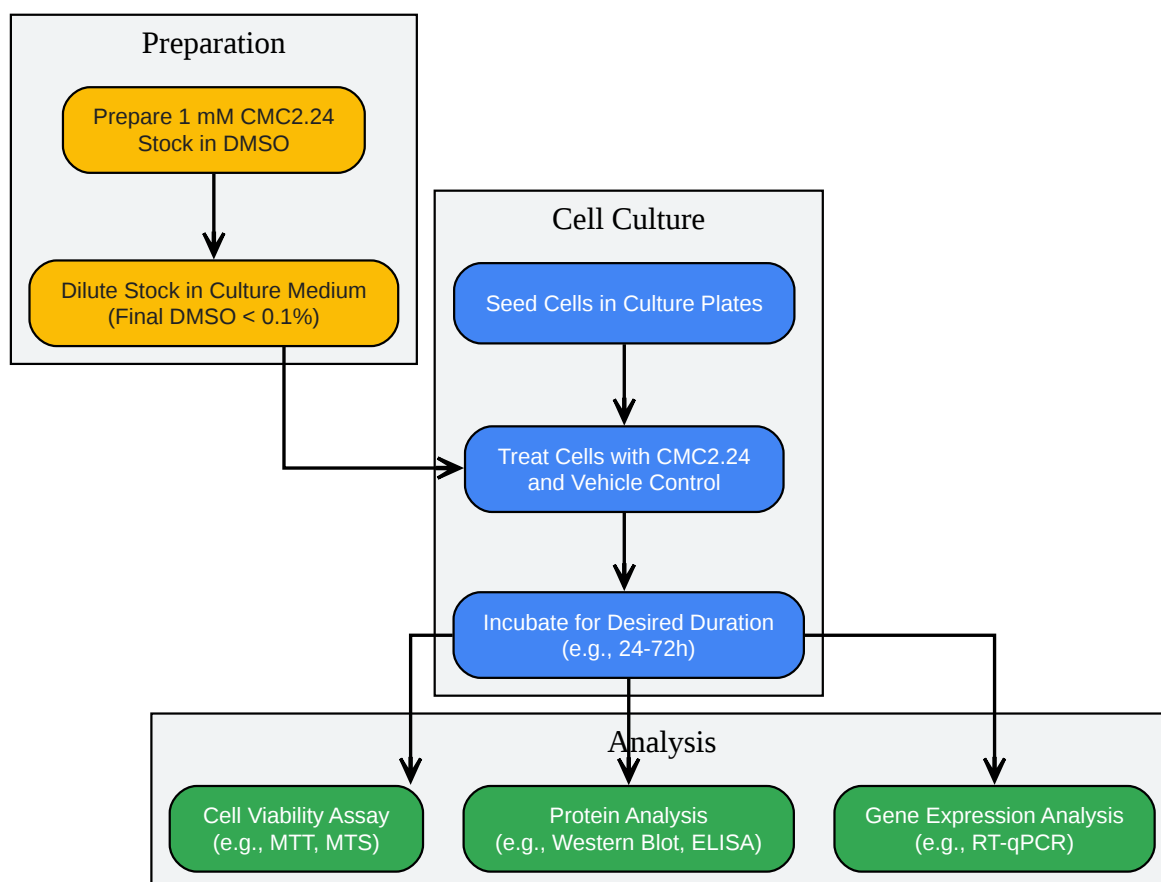

[Click to download full resolution via product page](#)

Caption: General experimental workflow for **CMC2.24** in cell culture.

### Need Custom Synthesis?

BenchChem offers custom synthesis for rare earth carbides and specific isotopic labeling.

Email: [info@benchchem.com](mailto:info@benchchem.com) or [Request Quote Online](#).

## References

- [1. Frontiers | A Novel Chemically-Modified Curcumin 2.24: Short-Term Systemic Therapy for Natural Periodontitis in Dogs \[frontiersin.org\]](#)
- [2. dovepress.com \[dovepress.com\]](#)
- [3. Efficacy of a Novel Pleiotropic MMP-Inhibitor, CMC2.24, in a Long-Term Diabetes Rat Model with Severe Hyperglycemia-Induced Oral Bone Loss - PMC \[pmc.ncbi.nlm.nih.gov\]](#)
- [4. researchgate.net \[researchgate.net\]](#)
- [5. researchgate.net \[researchgate.net\]](#)
- [6. Novel Hydrogenated Derivatives of Chemically Modified Curcumin CMC2.24 Are Potent Inhibitors of Melanogenesis in an In Vitro Model: Influence of Degree of Hydrogenation \[mdpi.com\]](#)
- [7. caymanchem.com \[caymanchem.com\]](#)
- [8. tandfonline.com \[tandfonline.com\]](#)
- [9. Chemically-Modified Curcumin 2.24: A Novel Systemic Therapy for Natural Periodontitis in Dogs - PMC \[pmc.ncbi.nlm.nih.gov\]](#)
- [To cite this document: BenchChem. \[Application Notes and Protocols for CMC2.24 in Cell Culture Experiments\]. BenchChem, \[2026\]. \[Online PDF\]. Available at: \[https://www.benchchem.com/product/b15614030/docs#application-notes-and-protocols-for-cmc2-24-in-cell-culture-experiments\]](#)

---

### Disclaimer & Data Validity:

The information provided in this document is for Research Use Only (RUO) and is strictly not intended for diagnostic or therapeutic procedures. While BenchChem strives to provide accurate protocols, we make no warranties, express or implied, regarding the fitness of this product for every specific experimental setup.

**Technical Support:** The protocols provided are for reference purposes. Unsure if this reagent suits your experiment?

**Need Industrial/Bulk Grade?** [Request Custom Synthesis Quote](#)

# BenchChem

Our mission is to be the trusted global source of essential and advanced chemicals, empowering scientists and researchers to drive progress in science and industry.

## Contact

Address: 3281 E Guasti Rd

Ontario, CA 91761, United States

Phone: (601) 213-4426

Email: [info@benchchem.com](mailto:info@benchchem.com)

[Contact our Ph.D. Support Team for a compatibility check](#)