

Application Notes and Protocols for AT791 in TLR Signaling Pathway Analysis

Author: BenchChem Technical Support Team. **Date:** April 2026

Compound of Interest

Compound Name: AT791
Cat. No.: B15614096

[Get Quote](#)

For Researchers, Scientists, and Drug Development Professionals

Introduction

AT791 is a potent, orally bioavailable small molecule inhibitor of Toll-like receptor 7 (TLR7) and Toll-like receptor 9 (TLR9) signaling.[1][2] These endosomal TLRs are key players in the innate immune system, recognizing single-stranded RNA (ssRNA) and unmethylated CpG DNA, respectively.[3][4] Dysregulation of TLR7 and TLR9 signaling is implicated in the pathogenesis of various autoimmune diseases, including systemic lupus erythematosus (SLE).[2][5][6] **AT791** presents a valuable tool for investigating the role of TLR7 and TLR9 in disease models and for the development of novel therapeutics.

The mechanism of action for **AT791** involves its accumulation in the acidic intracellular compartments where TLR7 and TLR9 are located.[2][7] As a lipophilic weak base, **AT791** becomes protonated and trapped within these endosomes.[1] It is believed to inhibit signaling by interacting with nucleic acids, thereby preventing their binding to the TLRs.[2][7] This application note provides detailed protocols for utilizing **AT791** to analyze its effects on the TLR7 and TLR9 signaling pathways.

Quantitative Data Summary

The inhibitory activity of **AT791** on TLR7 and TLR9 signaling has been characterized in various in vitro and in vivo models. The following tables summarize the key quantitative data.

Parameter	HEK293/TLR9 Cells	HEK293/TLR7 Cells	Reference
IC50 (CpG DNA stimulation)	0.04 μ M	-	[8]
IC50 (R848 stimulation)	-	3.33 μ M	[8]

Table 1: In vitro inhibitory activity of **AT791** on human TLR7 and TLR9 signaling in HEK293 cells.

Parameter	In Vivo Effect	Reference
CpG-induced IL-6 suppression in mice	Effective at 20 mg/kg (p.o.)	[1]

Table 2: In vivo efficacy of **AT791** in a mouse model.

Signaling Pathways and Mechanism of Action

The following diagrams illustrate the TLR7/9 signaling pathway and the proposed mechanism of action for **AT791**.

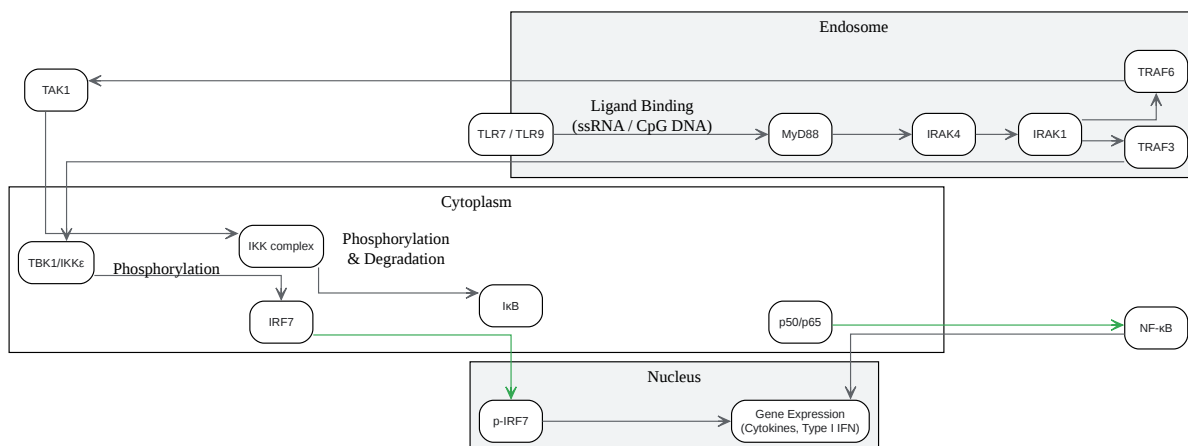

[Click to download full resolution via product page](#)

Caption: Simplified TLR7 and TLR9 signaling pathway.

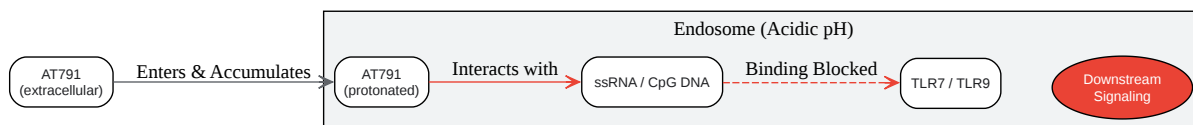

[Click to download full resolution via product page](#)

Caption: Proposed mechanism of action of **AT791**.

Experimental Protocols

The following protocols provide detailed methodologies for assessing the inhibitory effect of **AT791** on TLR7 and TLR9 signaling.

Protocol 1: In Vitro Inhibition of TLR7/9 Signaling in Human PBMCs

This protocol describes the measurement of cytokine production from human peripheral blood mononuclear cells (PBMCs) following stimulation with TLR7 and TLR9 agonists in the presence of **AT791**.

Materials:

- Human PBMCs, isolated from healthy donors
- RPMI 1640 medium supplemented with 10% FBS, 1% Penicillin-Streptomycin
- **AT791** (dissolved in DMSO)
- CpG-A ODN 2216 (TLR9 agonist)
- R848 (TLR7 agonist)
- 96-well cell culture plates
- Human IFN- α and IL-6 ELISA kits
- CO2 incubator (37°C, 5% CO2)

Procedure:

- Cell Plating: Seed human PBMCs at a density of 1×10^6 cells/mL in a 96-well plate (100 μ L/well).
- Compound Treatment: Prepare serial dilutions of **AT791** in culture medium. Add 50 μ L of the **AT791** dilutions to the respective wells. Include a vehicle control (DMSO) group. Pre-incubate the cells with the compound for 1 hour at 37°C.

- **TLR Agonist Stimulation:** Prepare solutions of CpG-A ODN (final concentration 1 μ M) and R848 (final concentration 1 μ M) in culture medium. Add 50 μ L of the agonist solutions to the appropriate wells. Include an unstimulated control group.
- **Incubation:** Incubate the plate for 24 hours at 37°C in a 5% CO₂ incubator.
- **Cytokine Measurement:** After incubation, centrifuge the plate at 400 x g for 5 minutes. Collect the supernatants and measure the concentrations of IFN- α and IL-6 using ELISA kits according to the manufacturer's instructions.
- **Data Analysis:** Calculate the percentage of inhibition of cytokine production by **AT791** at each concentration relative to the vehicle control. Determine the IC₅₀ value by plotting the percentage of inhibition against the log of the **AT791** concentration and fitting the data to a four-parameter logistic curve.

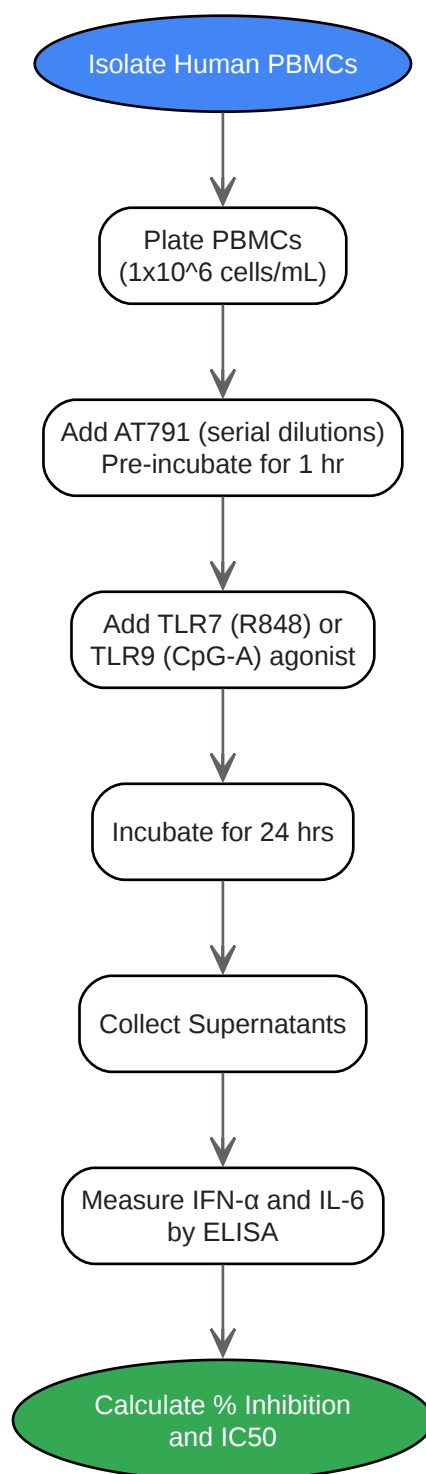

[Click to download full resolution via product page](#)

Caption: Experimental workflow for Protocol 1.

Protocol 2: Western Blot Analysis of IRF7 and NF- κ B Phosphorylation

This protocol details the procedure for assessing the effect of **AT791** on the phosphorylation of key downstream signaling molecules, IRF7 and NF- κ B (p65 subunit), in TLR7/9-stimulated cells.

Materials:

- Human plasmacytoid dendritic cells (pDCs) or a suitable cell line (e.g., RAW 264.7)
- DMEM or RPMI 1640 medium with 10% FBS
- **AT791** (dissolved in DMSO)
- CpG-A ODN 2216 or R848
- 6-well cell culture plates
- RIPA lysis buffer with protease and phosphatase inhibitors
- BCA protein assay kit
- SDS-PAGE gels and running buffer
- PVDF membrane
- Blocking buffer (5% non-fat dry milk or BSA in TBST)
- Primary antibodies: anti-phospho-IRF7 (Ser471/472), anti-IRF7, anti-phospho-NF- κ B p65 (Ser536), anti-NF- κ B p65, anti- β -actin
- HRP-conjugated secondary antibody
- ECL Western blotting substrate
- Chemiluminescence imaging system

Procedure:

- **Cell Culture and Treatment:** Seed cells in 6-well plates and allow them to adhere overnight. Pre-treat the cells with **AT791** at the desired concentrations for 1 hour.
- **Stimulation:** Stimulate the cells with CpG-A ODN or R848 for 15-60 minutes (time course may need to be optimized).
- **Cell Lysis:** Wash the cells with ice-cold PBS and lyse them with RIPA buffer.
- **Protein Quantification:** Determine the protein concentration of the lysates using a BCA assay.
- **SDS-PAGE and Western Blotting:**
 - Load equal amounts of protein (20-30 µg) onto an SDS-PAGE gel.
 - Separate the proteins by electrophoresis and transfer them to a PVDF membrane.
 - Block the membrane with blocking buffer for 1 hour at room temperature.
 - Incubate the membrane with primary antibodies overnight at 4°C.
 - Wash the membrane with TBST and incubate with the HRP-conjugated secondary antibody for 1 hour at room temperature.
 - Wash the membrane again and develop the blot using an ECL substrate.
- **Image Acquisition and Analysis:** Capture the chemiluminescent signal using an imaging system. Quantify the band intensities and normalize the phosphorylated protein levels to the total protein levels.

Conclusion

AT791 is a specific and potent inhibitor of TLR7 and TLR9 signaling, making it an invaluable research tool for dissecting the roles of these receptors in immunity and disease. The protocols provided in this application note offer robust methods for characterizing the inhibitory activity of **AT791** and investigating its effects on downstream signaling pathways. These experimental

frameworks can be adapted for various cell types and research questions, facilitating further exploration into the therapeutic potential of targeting TLR7 and TLR9.

Need Custom Synthesis?

BenchChem offers custom synthesis for rare earth carbides and specific isotopic labeling.

Email: info@benchchem.com or [Request Quote Online](#).

References

- [1. researchgate.net \[researchgate.net\]](https://www.researchgate.net)
- [2. Novel small molecule inhibitors of TLR7 and TLR9: mechanism of action and efficacy in vivo - PubMed \[pubmed.ncbi.nlm.nih.gov\]](https://pubmed.ncbi.nlm.nih.gov/)
- [3. AT791 | TLR7 inhibitor | TLR9 inhibitor | TargetMol \[targetmol.com\]](https://www.targetmol.com/)
- [4. miltenyibiotec.com \[miltenyibiotec.com\]](https://www.miltenyibiotec.com/)
- [5. Epicutaneous application of toll-like receptor 7 agonists leads to systemic autoimmunity in wild-type mice: a new model of systemic Lupus erythematosus - PubMed \[pubmed.ncbi.nlm.nih.gov\]](https://pubmed.ncbi.nlm.nih.gov/)
- [6. mdpi.com \[mdpi.com\]](https://www.mdpi.com/)
- [7. The TLR7/8 agonist R848 optimizes host and tumor immunity to improve therapeutic efficacy in murine lung cancer - PMC \[pmc.ncbi.nlm.nih.gov\]](https://pubmed.ncbi.nlm.nih.gov/)
- [8. medchemexpress.com \[medchemexpress.com\]](https://www.medchemexpress.com/)
- To cite this document: BenchChem. [Application Notes and Protocols for AT791 in TLR Signaling Pathway Analysis]. BenchChem, [2026]. [Online PDF]. Available at: [\[https://www.benchchem.com/product/b15614096/docs#application-notes-and-protocols-for-at791-in-tlr-signaling-pathway-analysis\]](https://www.benchchem.com/product/b15614096/docs#application-notes-and-protocols-for-at791-in-tlr-signaling-pathway-analysis)

Disclaimer & Data Validity:

The information provided in this document is for Research Use Only (RUO) and is strictly not intended for diagnostic or therapeutic procedures. While BenchChem strives to provide accurate protocols, we make no warranties, express or implied, regarding the fitness of this product for every specific experimental setup.

Technical Support: The protocols provided are for reference purposes. Unsure if this reagent suits your experiment?

Need Industrial/Bulk Grade? [Request Custom Synthesis Quote](#)

BenchChem

Our mission is to be the trusted global source of essential and advanced chemicals, empowering scientists and researchers to drive progress in science and industry.

Contact

Address: 3281 E Guasti Rd
Ontario, CA 91761, United States
Phone: (601) 213-4426
Email: info@benchchem.com

[Contact our Ph.D. Support Team for a compatibility check](#)