

The Role of CP-346086 in Cholesterol Reduction: A Technical Guide

Author: BenchChem Technical Support Team. **Date:** April 2026

Compound of Interest

Compound Name: CP-346086

Cat. No.: B15613185

[Get Quote](#)

For Researchers, Scientists, and Drug Development Professionals

This technical guide provides an in-depth overview of the mechanism of action, experimental data, and relevant biological pathways associated with **CP-346086**, a potent inhibitor of microsomal triglyceride transfer protein (MTP), and its role in cholesterol and triglyceride reduction.

Core Mechanism of Action: MTP Inhibition

CP-346086 exerts its lipid-lowering effects by directly inhibiting the microsomal triglyceride transfer protein (MTP).^{[1][2][3][4][5][6][7][8][9]} MTP is an essential intracellular lipid transfer protein located in the endoplasmic reticulum of hepatocytes and enterocytes. Its primary function is to facilitate the assembly of apolipoprotein B (apoB)-containing lipoproteins, namely very-low-density lipoproteins (VLDL) in the liver and chylomicrons in the intestine.^{[1][3][4][5][8][9]} By binding to MTP, **CP-346086** blocks the transfer of triglycerides, cholesterol esters, and phospholipids to nascent apoB, thereby preventing the formation and subsequent secretion of these lipoproteins into the circulation.^{[1][3][4][5][8][9]}

Quantitative Efficacy of CP-346086

The inhibitory potency and lipid-lowering efficacy of **CP-346086** have been quantified in various preclinical and clinical settings.

Table 1: In Vitro Inhibitory Activity of CP-346086

Parameter	Cell/Enzyme Source	Value	Reference
MTP Inhibition IC ₅₀	Human and Rodent MTP	2.0 nM	[1][2]
ApoB & Triglyceride Secretion IC ₅₀	Hep-G2 cells	2.6 nM	[1][2]

Table 2: In Vivo Efficacy of CP-346086 in Rodent Models

Species	Dosage	Duration	Parameter	Reduction	Reference
Rats/Mice	1.3 mg/kg (single dose)	2 hours	Plasma Triglycerides (ED ₃₀)	30%	[1][2]
Rats/Mice	10 mg/kg/day	2 weeks	Total Cholesterol	23%	[1][2]
VLDL Cholesterol	33%	[1][2]			
LDL Cholesterol	75%	[1][2]			
Triglycerides	62%	[1][2]			

Table 3: Clinical Efficacy of CP-346086 in Healthy Human Volunteers

Dosage	Duration	Parameter	ED ₅₀ / Maximal Inhibition	Reference
Single Oral Dose	4 hours	Plasma Triglycerides	ED ₅₀ : 10 mg; Max Inhibition (100 mg): 66%	[1][2]
VLDL Cholesterol	ED ₅₀ : 3 mg; Max Inhibition (100 mg): 87%	[1][2]		
30 mg/day	2 weeks	Total Cholesterol	47% reduction	[1][2]
LDL Cholesterol	72% reduction	[1][2]		
Triglycerides	75% reduction	[1][2]		
HDL Cholesterol	Little change	[1][2]		

Signaling and Metabolic Pathways

The primary pathway affected by **CP-346086** is the intracellular assembly and secretion of apoB-containing lipoproteins.

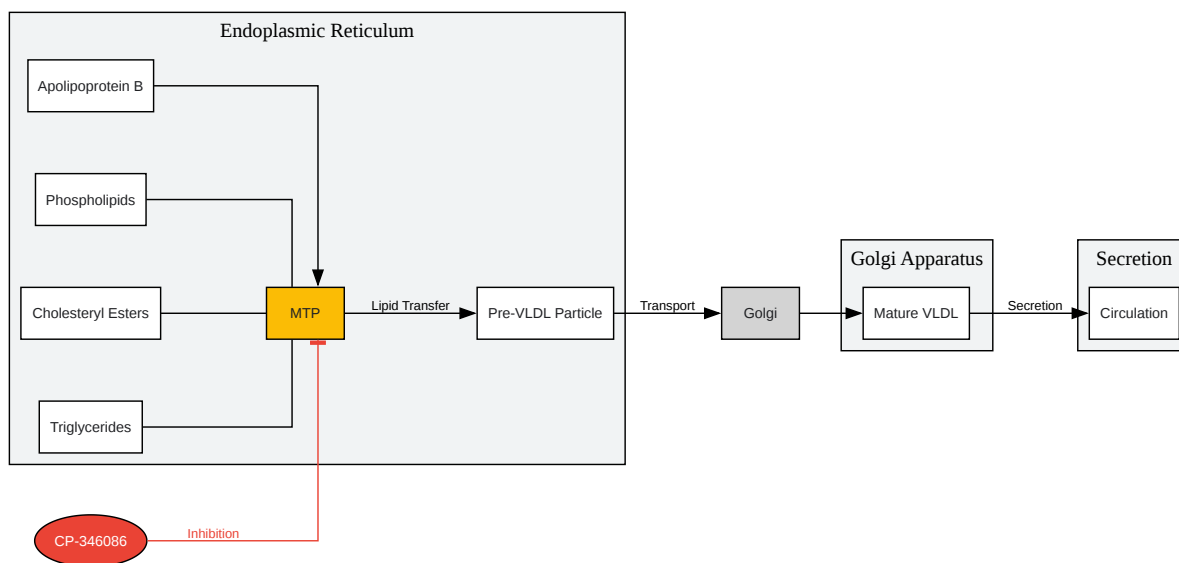

[Click to download full resolution via product page](#)

Figure 1. Mechanism of MTP inhibition by **CP-346086** in hepatocytes.

Experimental Protocols

In Vitro MTP Inhibition Assay

Objective: To determine the half-maximal inhibitory concentration (IC_{50}) of **CP-346086** on MTP activity.

Methodology:

- Source of MTP: Microsomes are prepared from human or rodent liver tissue or from cell lines expressing MTP (e.g., Hep-G2).

- **Assay Principle:** A fluorescence-based assay is commonly used. It measures the transfer of a fluorescently labeled lipid substrate (e.g., triglyceride) from donor vesicles to acceptor vesicles, catalyzed by MTP.
- **Procedure:**
 - Varying concentrations of **CP-346086** are pre-incubated with the MTP-containing microsomes.
 - The reaction is initiated by adding the donor and acceptor vesicles.
 - The increase in fluorescence in the acceptor vesicle fraction is monitored over time.
 - The rate of lipid transfer is calculated for each inhibitor concentration.
- **Data Analysis:** The IC_{50} value is determined by plotting the percentage of inhibition against the logarithm of the inhibitor concentration and fitting the data to a sigmoidal dose-response curve.

ApoB and Triglyceride Secretion in Hep-G2 Cells

Objective: To assess the effect of **CP-346086** on the secretion of apoB and triglycerides from a human hepatoma cell line.

Methodology:

- **Cell Culture:** Hep-G2 cells are cultured to confluence in appropriate media.
- **Treatment:** The cells are treated with various concentrations of **CP-346086** for a specified period (e.g., 24 hours).
- **Sample Collection:** The cell culture medium is collected.
- **Quantification:**
 - **ApoB:** The concentration of apoB in the medium is quantified using an enzyme-linked immunosorbent assay (ELISA).

- Triglycerides: The triglyceride content in the medium is measured using a commercially available enzymatic assay kit.
- Data Analysis: The IC_{50} for the inhibition of secretion is calculated similarly to the MTP inhibition assay.

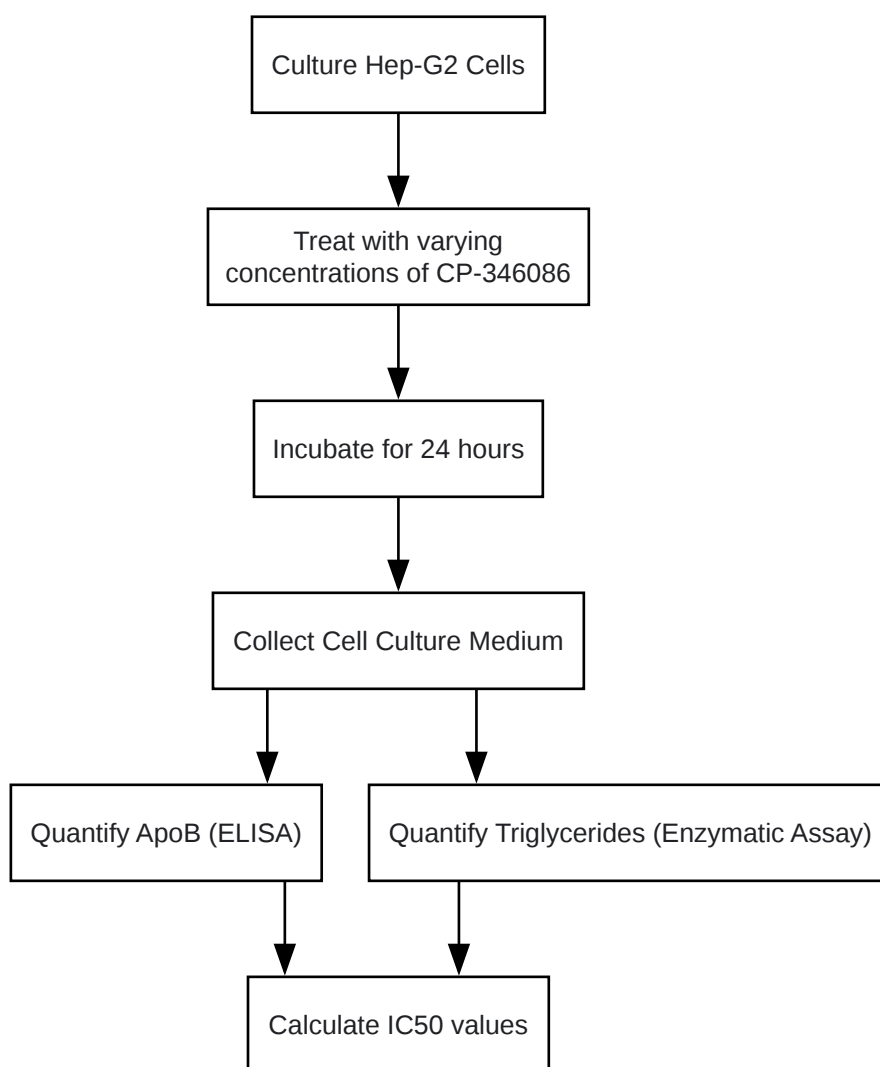

[Click to download full resolution via product page](#)

Figure 2. Workflow for assessing ApoB and triglyceride secretion in Hep-G2 cells.

In Vivo Lipid-Lowering Efficacy in Rodents

Objective: To evaluate the effect of oral administration of **CP-346086** on plasma lipid profiles in rats or mice.

Methodology:

- **Animal Model:** Male Sprague-Dawley rats or C57BL/6 mice are commonly used.
- **Acclimation:** Animals are acclimated for at least one week before the study.
- **Dosing:** **CP-346086** is formulated in a suitable vehicle (e.g., 0.5% methylcellulose) and administered orally by gavage. A control group receives the vehicle only.
- **Blood Sampling:** Blood samples are collected at specified time points (e.g., pre-dose and several hours post-dose for acute studies, or at the end of a chronic treatment period) via retro-orbital bleeding or cardiac puncture.
- **Lipid Analysis:** Plasma is separated, and concentrations of total cholesterol, VLDL cholesterol, LDL cholesterol, HDL cholesterol, and triglycerides are determined using enzymatic assays and lipoprotein fractionation methods (e.g., ultracentrifugation or FPLC).
- **Statistical Analysis:** The percentage change in lipid parameters from baseline or compared to the control group is calculated. Statistical significance is determined using appropriate tests (e.g., t-test or ANOVA).

Potential Side Effects and Considerations

The primary side effect associated with MTP inhibition is the accumulation of triglycerides in the liver and intestine.^{[1][2][3][4][5]} This is a direct consequence of the mechanism of action, as the lipids that are not secreted accumulate within the cells. This can lead to hepatic steatosis (fatty liver) and gastrointestinal adverse effects such as diarrhea and steatorrhea.^{[3][9][10]} Studies have shown that administering the drug away from meals can mitigate the intestinal lipid accumulation.^{[1][2][4]}

Conclusion

CP-346086 is a highly potent inhibitor of microsomal triglyceride transfer protein that demonstrates significant efficacy in reducing plasma levels of total cholesterol, VLDL cholesterol, LDL cholesterol, and triglycerides in both animal models and humans. Its mechanism of action, centered on the inhibition of apoB-containing lipoprotein assembly and secretion, provides a powerful therapeutic approach for hyperlipidemia. However, the on-target

side effect of lipid accumulation in the liver and gut requires careful consideration in its clinical development and potential therapeutic application. The data presented in this guide underscore the robust lipid-lowering capabilities of **CP-346086** and provide a framework for further research and development in this area.

Need Custom Synthesis?

BenchChem offers custom synthesis for rare earth carbides and specific isotopic labeling.

Email: info@benchchem.com or [Request Quote Online](#).

References

- [1. CP-346086: an MTP inhibitor that lowers plasma cholesterol and triglycerides in experimental animals and in humans - PubMed \[pubmed.ncbi.nlm.nih.gov\]](#)
- [2. \[PDF\] CP-346086: an MTP inhibitor that lowers plasma cholesterol and triglycerides in experimental animals and in humans. | Semantic Scholar \[semanticscholar.org\]](#)
- [3. New approaches to target microsomal triglyceride transfer protein - PMC \[pmc.ncbi.nlm.nih.gov\]](#)
- [4. storage.imrpress.com \[storage.imrpress.com\]](#)
- [5. JTT-130, a microsomal triglyceride transfer protein \(MTP\) inhibitor lowers plasma triglycerides and LDL cholesterol concentrations without increasing hepatic triglycerides in guinea pigs - PMC \[pmc.ncbi.nlm.nih.gov\]](#)
- [6. researchgate.net \[researchgate.net\]](#)
- [7. CP-346086 | MTP inhibitor | Probechem Biochemicals \[probechem.com\]](#)
- [8. researchgate.net \[researchgate.net\]](#)
- [9. The role of microsomal triglyceride transfer protein inhibitors in the treatment of patients with familial hypercholesterolemia: risks, benefits, and management - PubMed \[pubmed.ncbi.nlm.nih.gov\]](#)
- [10. MTP inhibition halves LDL in familial hypercholesterolemia \[medscape.com\]](#)
- To cite this document: BenchChem. [The Role of CP-346086 in Cholesterol Reduction: A Technical Guide]. BenchChem, [2026]. [Online PDF]. Available at: [\[https://www.benchchem.com/product/b15613185/docs#the-role-of-cp-346086-in-cholesterol-reduction-a-technical-guide\]](https://www.benchchem.com/product/b15613185/docs#the-role-of-cp-346086-in-cholesterol-reduction-a-technical-guide)

Disclaimer & Data Validity:

The information provided in this document is for Research Use Only (RUO) and is strictly not intended for diagnostic or therapeutic procedures. While BenchChem strives to provide accurate protocols, we make no warranties, express or implied, regarding the fitness of this product for every specific experimental setup.

Technical Support: The protocols provided are for reference purposes. Unsure if this reagent suits your experiment?

Need Industrial/Bulk Grade? [Request Custom Synthesis Quote](#)

BenchChem

Our mission is to be the trusted global source of essential and advanced chemicals, empowering scientists and researchers to drive progress in science and industry.

Contact

Address: 3281 E Guasti Rd
Ontario, CA 91761, United States
Phone: (601) 213-4426
Email: info@benchchem.com

[Contact our Ph.D. Support Team for a compatibility check](#)