

# Technical Support Center: Dissolving BMS-1166 with Sonication

**Author:** BenchChem Technical Support Team. **Date:** April 2026

## Compound of Interest

Compound Name: BMS-1166

Cat. No.: B15613458

[Get Quote](#)

This technical support center provides researchers, scientists, and drug development professionals with comprehensive guidance on utilizing sonication for the effective dissolution of **BMS-1166**. Below you will find troubleshooting guides, frequently asked questions, detailed experimental protocols, and relevant technical data.

## Troubleshooting Guide

Encountering issues while dissolving **BMS-1166**? Consult the guide below for common problems and their solutions.

Problem	Possible Cause(s)	Recommended Solution(s)
BMS-1166 powder is not dissolving in DMSO, even with vortexing.	The concentration may be too high for simple vortexing to be effective. Insufficient mechanical energy to break down compound aggregates.	Use a bath sonicator or a probe sonicator to provide additional energy. Sonicate in short bursts (e.g., 5-10 seconds on, 15-20 seconds off) to prevent overheating. Ensure you are using fresh, anhydrous DMSO as absorbed moisture can reduce solubility. [1]
Precipitation occurs when diluting the DMSO stock solution into an aqueous buffer.	The compound is crashing out of solution due to the change in solvent polarity. The final concentration in the aqueous buffer is above its solubility limit.	Decrease the final concentration of BMS-1166 in the aqueous medium. Consider adding a surfactant (e.g., Tween-20 at 0.01-0.1%) or a co-solvent (e.g., PEG300, ethanol) to the aqueous buffer to improve solubility.[2] When diluting, add the DMSO stock to the aqueous buffer slowly while vortexing to ensure rapid mixing.
The solution appears cloudy or contains visible particulates after sonication.	Incomplete dissolution. The sonication time or intensity was insufficient. The compound may have degraded due to excessive heat.	Visually inspect the solution. If particulates remain, continue sonication in short, pulsed intervals while keeping the sample on ice.[2] If cloudiness persists, it might indicate the formation of very fine, insoluble aggregates. In such cases, centrifugation or filtration (using a 0.22 µm filter) can be used to clarify the solution, but this may reduce the actual concentration. Consider that

sonication can sometimes generate sub-micron particles, giving the illusion of dissolution.[3]

---

Inconsistent experimental results using the prepared BMS-1166 solution.	The actual concentration of the soluble compound is lower than the intended concentration due to incomplete dissolution or precipitation. The compound may have degraded during preparation.	Always ensure the solution is clear before use. Prepare fresh working solutions for each experiment.[4] When possible, verify the concentration of your final solution using an appropriate analytical method like HPLC.
---	--	--

---

## Frequently Asked Questions (FAQs)

Q1: Why is sonication recommended for dissolving **BMS-1166**?

A1: Sonication utilizes high-frequency sound waves to create cavitation, a process where microscopic bubbles form and collapse. This generates intense local energy, which helps to break apart solid particles and increase the surface area exposed to the solvent, thereby accelerating dissolution, especially for compounds with poor solubility.[5][6] For **BMS-1166**, particularly at high concentrations in DMSO, sonication provides the necessary energy to overcome the forces holding the compound in a solid state.[7]

Q2: What type of sonicator should I use: a bath or a probe sonicator?

A2: For dissolving small volumes of compounds in vials or tubes, a bath sonicator is generally sufficient and convenient.[5] It provides indirect sonication and is less likely to cause overheating. A probe sonicator delivers more focused and intense energy, which can be useful for very difficult-to-dissolve compounds or larger volumes. However, it also generates more heat and requires careful control to prevent sample degradation.

Q3: Can I heat the solution to aid in dissolving **BMS-1166**?

A3: Gentle heating (e.g., a 37°C water bath) can be used in conjunction with sonication to help dissolve **BMS-1166**. [2] However, it is crucial to be cautious as excessive heat can lead to the

degradation of the compound. It is recommended to use minimal heat and for the shortest duration necessary.

Q4: Will sonication degrade my **BMS-1166** compound?

A4: Prolonged sonication, especially with a high-intensity probe sonicator, can generate significant heat, which may lead to the degradation of temperature-sensitive compounds. To mitigate this risk, it is recommended to sonicate in short pulses and to keep the sample vessel on ice or in a cooling bath during the process.[2] For most small molecules, sonication under controlled temperature conditions is unlikely to cause degradation.[8]

Q5: What is the maximum recommended concentration of DMSO in my cell-based assays?

A5: For most cell-based assays, the final concentration of DMSO should be kept low, typically below 0.5% (v/v), to avoid solvent-induced cytotoxicity or other off-target effects. It is always best to determine the tolerance of your specific cell line to DMSO in a preliminary experiment.

## Quantitative Data Summary

The solubility of **BMS-1166** in various solvents is summarized below. Please note that sonication is often recommended to achieve these concentrations.

Solvent	Maximum Solubility	Molar Concentration	Reference
DMSO	125 mg/mL	194.97 mM	[9]
DMSO	100 mg/mL	155.97 mM	[1]
Ethanol	13 mg/mL	20.28 mM	[1]
Water	Insoluble	N/A	[1]
In vivo Formulation 1			
10% DMSO + 40% PEG300 + 5% Tween-80 + 45% Saline	≥ 2.08 mg/mL	≥ 3.24 mM	[4]
In vivo Formulation 2			
10% DMSO + 90% (20% SBE-β-CD in Saline)	≥ 2.08 mg/mL	≥ 3.24 mM	[4]
In vivo Formulation 3			
10% DMSO + 90% Corn Oil	≥ 2.08 mg/mL	≥ 3.24 mM	[4]

Note: "≥" indicates that the solubility is at least the value stated, but the saturation point was not determined.

## Experimental Protocols

### Protocol 1: Preparation of a High-Concentration BMS-1166 Stock Solution in DMSO

This protocol describes the preparation of a 100 mM stock solution of **BMS-1166** in DMSO.

Materials:

- **BMS-1166** powder (Molecular Weight: 641.11 g/mol )

- Anhydrous Dimethyl Sulfoxide (DMSO)
- Sterile microcentrifuge tubes or vials
- Vortex mixer
- Bath sonicator

Procedure:

- **Weighing the Compound:** Accurately weigh out the desired amount of **BMS-1166** powder. For example, to prepare 1 mL of a 100 mM solution, you would need 64.11 mg of **BMS-1166**.
- **Adding Solvent:** Add the calculated volume of anhydrous DMSO to the vial containing the **BMS-1166** powder.
- **Initial Mixing:** Tightly cap the vial and vortex vigorously for 1-2 minutes to create a suspension.
- **Sonication:**
  - Place the vial in a bath sonicator. Ensure the water level in the sonicator is sufficient to cover the level of the solution in the vial.
  - Sonicate in short bursts of 5-10 minutes. After each burst, visually inspect the solution for undissolved particles.
  - If necessary, gently vortex the vial between sonication cycles.
  - Continue this process until the solution is completely clear and no solid particles are visible. To prevent overheating, you can place the vial in an ice bath during sonication.
- **Final Check and Storage:** Once fully dissolved, briefly centrifuge the vial to ensure no undissolved material is present on the walls of the tube. Store the stock solution in small aliquots at -20°C or -80°C to avoid repeated freeze-thaw cycles.

## Visualizations

### BMS-1166 Mechanism of Action

**BMS-1166** is a small molecule inhibitor of the PD-1/PD-L1 interaction. It functions by binding to PD-L1, inducing its dimerization, and thereby blocking its interaction with the PD-1 receptor on T-cells.[4][10] This action alleviates the PD-L1-induced exhaustion of T-cells and restores their anti-tumor activity.[1][10]

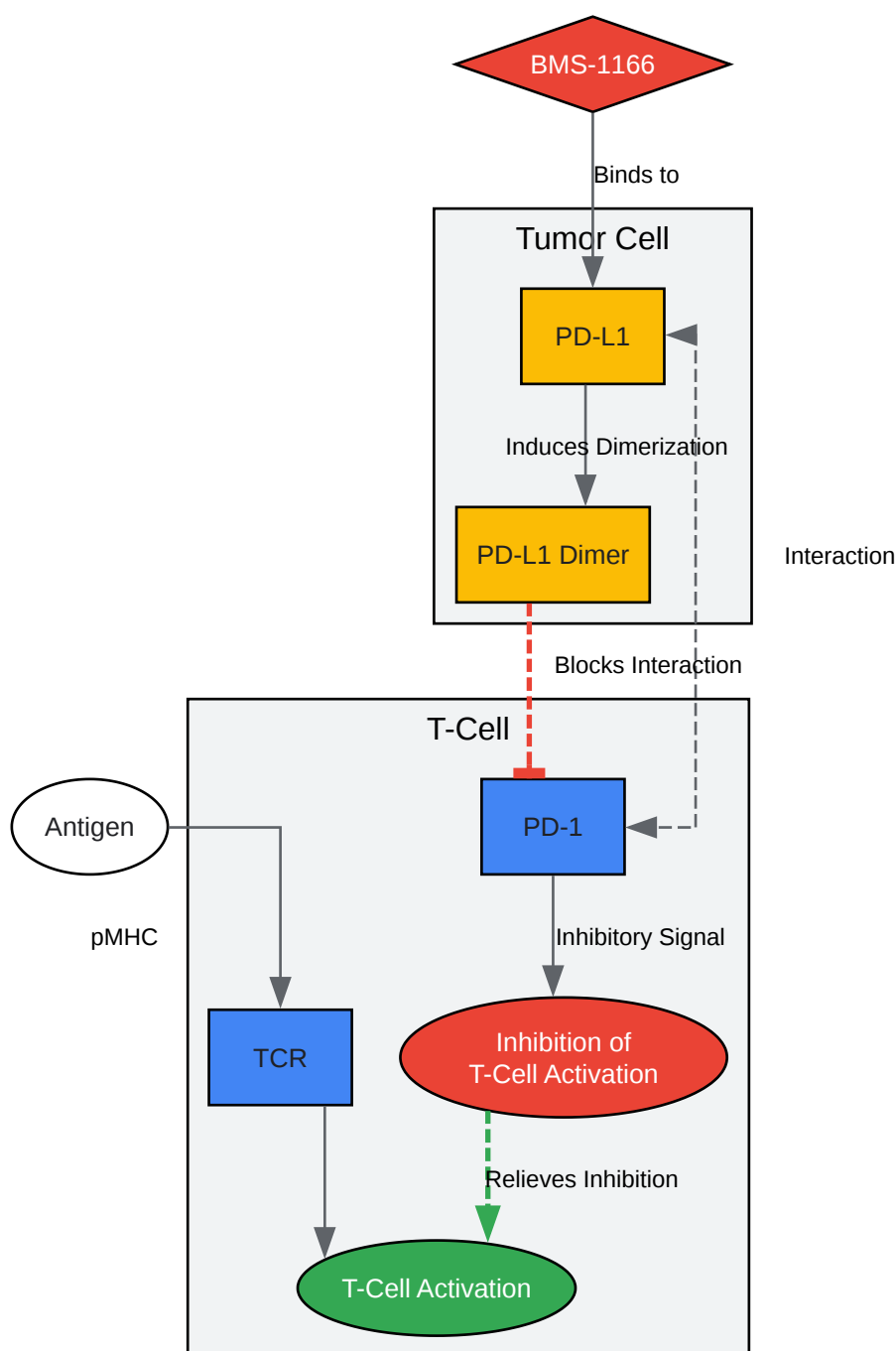

[Click to download full resolution via product page](#)

Caption: Signaling pathway of **BMS-1166** inhibiting the PD-1/PD-L1 interaction.

## Experimental Workflow for Dissolving **BMS-1166**

The following diagram illustrates the logical steps for preparing a **BMS-1166** solution, including troubleshooting checkpoints.

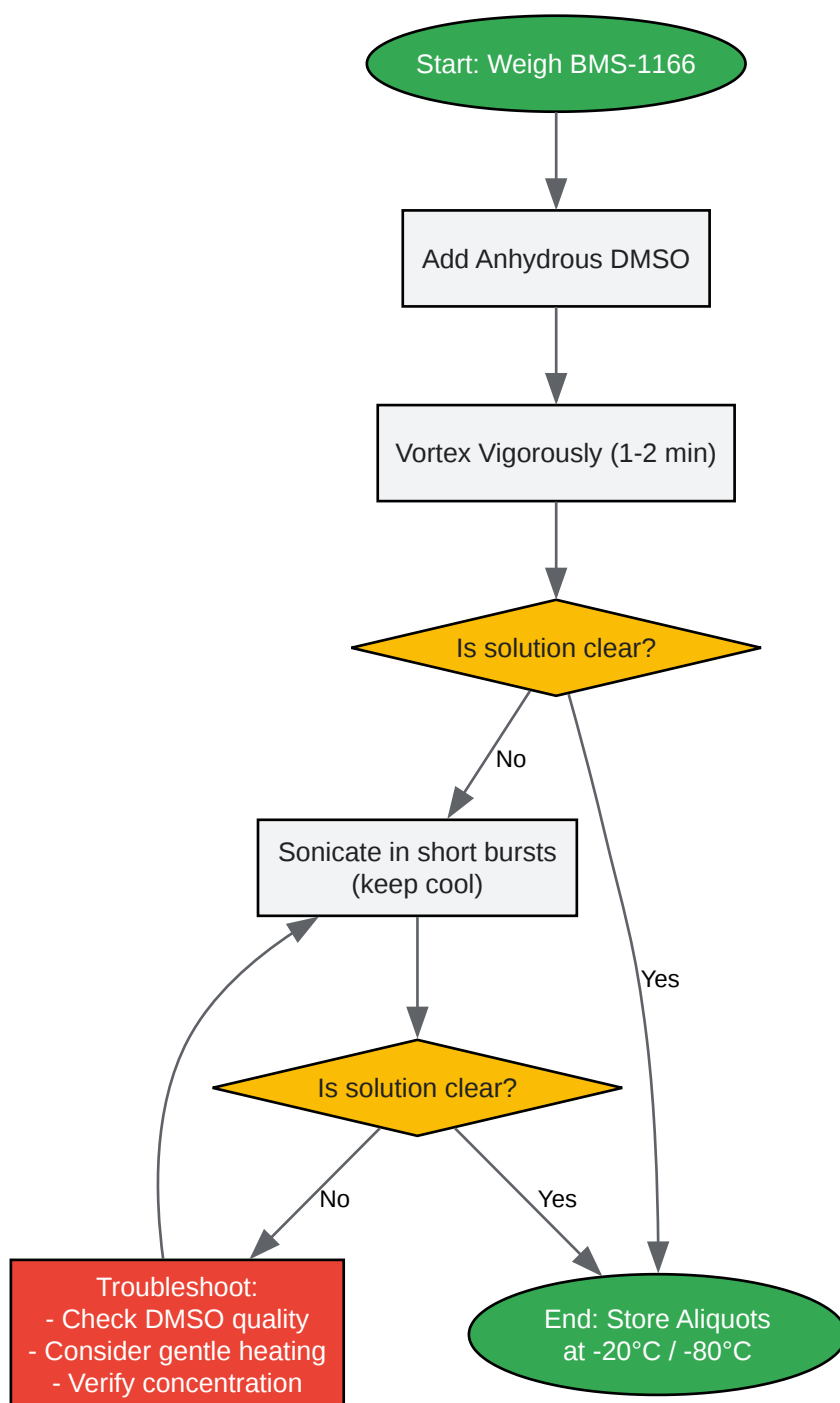

[Click to download full resolution via product page](#)

Caption: Workflow for dissolving **BMS-1166**, including troubleshooting steps.

### Need Custom Synthesis?

BenchChem offers custom synthesis for rare earth carbides and specific isotopic labeling.

Email: [info@benchchem.com](mailto:info@benchchem.com) or [Request Quote Online](#).

## References

- [1. selleckchem.com](https://www.selleckchem.com) [selleckchem.com]
- [2. benchchem.com](https://www.benchchem.com) [benchchem.com]
- [3. researchgate.net](https://www.researchgate.net) [researchgate.net]
- [4. medchemexpress.com](https://www.medchemexpress.com) [medchemexpress.com]
- [5. m.youtube.com](https://m.youtube.com) [m.youtube.com]
- [6. From Sound Waves to Soluble Liquids: Unveiling the Power of Sonication | Envirostar](#) [envirostarllc.com]
- [7. researchgate.net](https://www.researchgate.net) [researchgate.net]
- [8. researchgate.net](https://www.researchgate.net) [researchgate.net]
- [9. benchchem.com](https://www.benchchem.com) [benchchem.com]
- [10. Small-molecule inhibitors of PD-1/PD-L1 immune checkpoint alleviate the PD-L1-induced exhaustion of T-cells - PMC](#) [pmc.ncbi.nlm.nih.gov]
- To cite this document: BenchChem. [Technical Support Center: Dissolving BMS-1166 with Sonication]. BenchChem, [2026]. [Online PDF]. Available at: [\[https://www.benchchem.com/product/b15613458/docs#technical-support-center-dissolving-bms-1166-with-sonication\]](https://www.benchchem.com/product/b15613458/docs#technical-support-center-dissolving-bms-1166-with-sonication)

---

### Disclaimer & Data Validity:

The information provided in this document is for Research Use Only (RUO) and is strictly not intended for diagnostic or therapeutic procedures. While BenchChem strives to provide accurate protocols, we make no warranties, express or implied, regarding the fitness of this product for every specific experimental setup.

**Technical Support:** The protocols provided are for reference purposes. Unsure if this reagent suits your experiment?

**Need Industrial/Bulk Grade?** [Request Custom Synthesis Quote](#)

## BenchChem

Our mission is to be the trusted global source of essential and advanced chemicals, empowering scientists and researchers to drive progress in science and industry.

### Contact

Address: 3281 E Guasti Rd  
Ontario, CA 91761, United States  
Phone: (601) 213-4426  
Email: [info@benchchem.com](mailto:info@benchchem.com)

[Contact our Ph.D. Support Team for a compatibility check](#)