

Step-by-step guide to synthesizing SOS1 PROTACs using intermediates

Author: BenchChem Technical Support Team. **Date:** April 2026

Compound of Interest

Compound Name: *SOS1 Ligand intermediate-1*

Cat. No.: *B15613269*

[Get Quote](#)

Synthesizing SOS1 PROTACs: A Step-by-Step Guide for Researchers

Application Notes and Protocols for the Synthesis and Evaluation of SOS1-Targeting Proteolysis Targeting Chimeras (PROTACs) Using Key Intermediates.

This guide provides a comprehensive overview and detailed protocols for the synthesis of Son of Sevenless 1 (SOS1) PROTACs, aimed at researchers, scientists, and drug development professionals. By leveraging key chemical intermediates, this document outlines the synthetic strategies for creating bifunctional molecules capable of inducing the targeted degradation of SOS1, a critical guanine nucleotide exchange factor implicated in RAS-driven cancers.

Introduction to SOS1 PROTACs

Proteolysis Targeting Chimeras (PROTACs) are innovative heterobifunctional molecules designed to hijack the cell's ubiquitin-proteasome system to selectively degrade target proteins. A PROTAC consists of three key components: a "warhead" that binds to the protein of interest (in this case, SOS1), a ligand that recruits an E3 ubiquitin ligase (commonly Cereblon or VHL), and a chemical linker that connects the two. By bringing SOS1 and an E3 ligase into close

proximity, PROTACs facilitate the ubiquitination and subsequent degradation of SOS1, offering a powerful therapeutic strategy for cancers reliant on the RAS-MAPK signaling pathway.[1][2]

SOS1 Signaling Pathway

SOS1 is a crucial activator of KRAS, promoting the exchange of GDP for GTP and thereby switching on downstream signaling cascades that drive cell proliferation and survival.[3][4][5] Targeting SOS1 for degradation can effectively shut down this oncogenic signaling.



[Click to download full resolution via product page](#)

Caption: SOS1-mediated activation of the RAS/MAPK signaling pathway.

General Synthesis Workflow

The synthesis of SOS1 PROTACs is a modular process that involves three main stages:

- Synthesis of the SOS1 Binder (Warhead): This typically involves creating a derivative of a known SOS1 inhibitor, such as those based on quinazoline or pyrido[2,3-d]pyrimidin-7-one scaffolds, functionalized with a suitable point for linker attachment.[6][7]
- Synthesis of the E3 Ligase Ligand-Linker Intermediate: This involves attaching a linker with a reactive functional group to a recognized E3 ligase ligand, such as thalidomide (for CRBN) or a VHL ligand.[8][9][10]
- Final PROTAC Assembly: The SOS1 binder and the E3 ligase ligand-linker are coupled together, most commonly via an amide bond formation.[11][12]

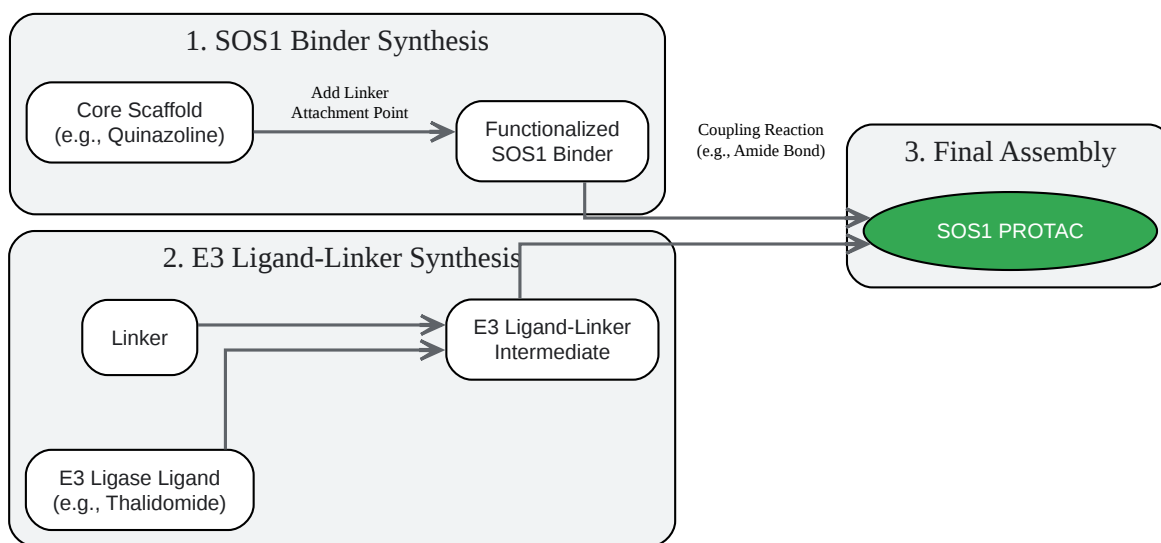

[Click to download full resolution via product page](#)

Caption: Modular workflow for the synthesis of SOS1 PROTACs.

Experimental Protocols

Protocol 1: Synthesis of a Quinazoline-Based SOS1 Binder Intermediate

This protocol describes the synthesis of a functionalized quinazoline core, a common scaffold for SOS1 inhibitors, adapted from literature procedures.[7][13][14]

Step 1.1: Synthesis of 2-amino-5-methoxybenzoic acid

- Materials: 5-Methoxy-2-nitrobenzoic acid, Palladium on carbon (10%), Methanol, Hydrogen gas.
- Procedure:
 - Dissolve 5-methoxy-2-nitrobenzoic acid in methanol in a flask suitable for hydrogenation.

- Carefully add 10% palladium on carbon to the solution.
- Purge the flask with hydrogen gas and maintain a hydrogen atmosphere (e.g., using a balloon).
- Stir the reaction mixture vigorously at room temperature for 4-6 hours, monitoring the reaction by TLC or LC-MS.
- Upon completion, filter the reaction mixture through a pad of Celite to remove the palladium catalyst.
- Concentrate the filtrate under reduced pressure to yield 2-amino-5-methoxybenzoic acid.

Step 1.2: Synthesis of 6-methoxy-2-(methylthio)quinazolin-4(3H)-one

- Materials: 2-amino-5-methoxybenzoic acid, Methyl isothiocyanate, Ethanol.
- Procedure:
 - Suspend 2-amino-5-methoxybenzoic acid in ethanol.
 - Add methyl isothiocyanate to the suspension.
 - Reflux the reaction mixture for 8-12 hours, monitoring by TLC or LC-MS.
 - Cool the reaction mixture to room temperature, and collect the resulting precipitate by filtration.
 - Wash the precipitate with cold ethanol and dry under vacuum to obtain the desired product.

Step 1.3: Synthesis of 4-chloro-6-methoxy-2-(methylthio)quinazoline

- Materials: 6-methoxy-2-(methylthio)quinazolin-4(3H)-one, Phosphorus oxychloride (POCl₃), N,N-Dimethylaniline.
- Procedure:

- Carefully add 6-methoxy-2-(methylthio)quinazolin-4(3H)-one to phosphorus oxychloride.
- Add a catalytic amount of N,N-dimethylaniline.
- Heat the mixture at reflux for 2-4 hours.
- Cool the reaction to room temperature and carefully pour it onto crushed ice.
- Neutralize the mixture with a saturated sodium bicarbonate solution.
- Extract the product with dichloromethane, dry the organic layer over anhydrous sodium sulfate, and concentrate under reduced pressure.
- Purify the crude product by column chromatography on silica gel.

Step 1.4: Synthesis of N-(4-((6-methoxy-2-(methylthio)quinazolin-4-yl)amino)phenyl)acrylamide (SOS1 Binder with Linker Attachment Point)

- Materials: 4-chloro-6-methoxy-2-(methylthio)quinazoline, N-(4-aminophenyl)acrylamide, Isopropanol, HCl (catalytic).
- Procedure:
 - Dissolve 4-chloro-6-methoxy-2-(methylthio)quinazoline and N-(4-aminophenyl)acrylamide in isopropanol.
 - Add a catalytic amount of concentrated HCl.
 - Heat the reaction mixture at reflux for 6-8 hours.
 - Cool the reaction to room temperature and collect the precipitate by filtration.
 - Wash the solid with isopropanol and dry to yield the final SOS1 binder intermediate.

Protocol 2: Synthesis of a Thalidomide-Linker Intermediate

This protocol outlines the preparation of a thalidomide derivative with a linker ready for coupling to the SOS1 binder, based on established methods.[8][15]

Step 2.1: Synthesis of 2-(2,6-dioxopiperidin-3-yl)-4-fluoroisoindoline-1,3-dione

- Materials: 4-Fluorophthalic anhydride, 3-aminopiperidine-2,6-dione hydrochloride, Acetic acid, Sodium acetate.
- Procedure:
 - Combine 4-fluorophthalic anhydride, 3-aminopiperidine-2,6-dione hydrochloride, and sodium acetate in acetic acid.
 - Heat the mixture at reflux for 4-6 hours.
 - Cool the reaction mixture and pour it into water.
 - Collect the precipitate by filtration, wash with water, and dry to obtain 4-fluorothalidomide.

Step 2.2: Synthesis of tert-butyl (2-(2-(2-((2-(2,6-dioxopiperidin-3-yl)-1,3-dioxoisoindolin-4-yl)amino)ethoxy)ethoxy)ethyl)carbamate (Thalidomide-PEG-Boc)

- Materials: 4-fluorothalidomide, tert-butyl (2-(2-(2-aminoethoxy)ethoxy)ethyl)carbamate, N,N-Diisopropylethylamine (DIPEA), Dimethyl sulfoxide (DMSO).
- Procedure:
 - Dissolve 4-fluorothalidomide and tert-butyl (2-(2-(2-aminoethoxy)ethoxy)ethyl)carbamate in DMSO.
 - Add DIPEA to the mixture.
 - Heat the reaction at 80-90°C for 12-16 hours.
 - Cool the reaction and dilute with water.
 - Extract the product with ethyl acetate, wash the organic layer with brine, dry over anhydrous sodium sulfate, and concentrate.

- Purify the crude product by column chromatography.

Step 2.3: Synthesis of 4-((2-(2-(2-aminoethoxy)ethoxy)ethyl)amino)-2-(2,6-dioxopiperidin-3-yl)isoindoline-1,3-dione (Thalidomide-PEG-Amine)

- Materials: Thalidomide-PEG-Boc, Trifluoroacetic acid (TFA), Dichloromethane (DCM).

- Procedure:

- Dissolve Thalidomide-PEG-Boc in DCM.
- Add TFA dropwise at 0°C.
- Stir the reaction at room temperature for 1-2 hours.
- Concentrate the reaction mixture under reduced pressure to remove the solvent and excess TFA.
- The resulting amine salt is typically used in the next step without further purification.

Protocol 3: Final Assembly of SOS1 PROTAC via Amide Coupling

This protocol describes the final coupling of the SOS1 binder and the thalidomide-linker intermediate.[\[11\]](#)[\[12\]](#)[\[16\]](#)

- Materials: SOS1 Binder with a carboxylic acid functional group (prepared by modifying the acrylamide), Thalidomide-PEG-Amine, HATU (1-[Bis(dimethylamino)methylene]-1H-1,2,3-triazolo[4,5-b]pyridinium 3-oxid hexafluorophosphate), DIPEA, Anhydrous Dimethylformamide (DMF).

- Procedure:

- Dissolve the SOS1 binder with a carboxylic acid in anhydrous DMF.
- Add HATU and DIPEA to the solution and stir for 15 minutes to activate the carboxylic acid.

- Add a solution of the Thalidomide-PEG-Amine in anhydrous DMF to the reaction mixture.
- Stir the reaction at room temperature for 4-8 hours under a nitrogen atmosphere.
- Monitor the reaction by LC-MS.
- Upon completion, dilute the reaction mixture with ethyl acetate and wash with saturated aqueous sodium bicarbonate, water, and brine.
- Dry the organic layer over anhydrous sodium sulfate and concentrate.
- Purify the final PROTAC by preparative HPLC.

Evaluation of SOS1 PROTACs

Once synthesized, the efficacy of the SOS1 PROTACs must be evaluated through a series of biochemical and cellular assays.

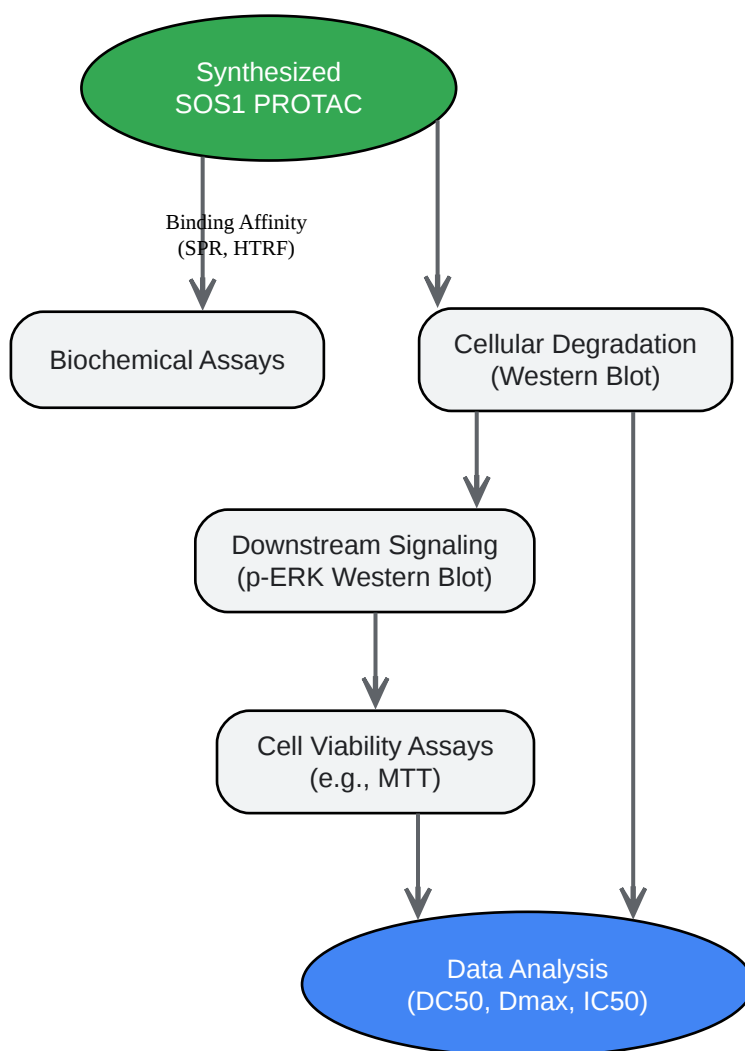

[Click to download full resolution via product page](#)

Caption: Experimental workflow for the evaluation of SOS1 PROTACs.

Protocol 4: Western Blot for SOS1 Degradation

- Materials: KRAS-mutant cancer cell line (e.g., SW620, NCI-H358), SOS1 PROTAC, DMSO, Cell lysis buffer, Primary antibodies (anti-SOS1, anti-GAPDH or anti- β -actin), HRP-conjugated secondary antibody, Chemiluminescent substrate.
- Procedure:
 - Seed cells in 6-well plates and allow them to adhere overnight.

- Treat the cells with varying concentrations of the SOS1 PROTAC (and a DMSO vehicle control) for a specified time (e.g., 24 hours).
- Lyse the cells and quantify the protein concentration of the lysates.
- Separate the protein lysates by SDS-PAGE and transfer the proteins to a PVDF membrane.
- Block the membrane and then incubate with the primary anti-SOS1 antibody overnight at 4°C.
- Wash the membrane and incubate with the HRP-conjugated secondary antibody.
- Detect the signal using a chemiluminescent substrate.
- Strip the membrane and re-probe with a loading control antibody (e.g., anti-GAPDH).
- Quantify the band intensities to determine the extent of SOS1 degradation.

Quantitative Data Summary

The following tables summarize key performance indicators for representative SOS1 PROTACs from the literature.

Table 1: SOS1 Degradation Potency (DC_{50} and D_{max})

PROTAC	Cell Line	DC_{50} (nM)	D_{max} (%)	E3 Ligase	Reference
11o	SW620	1.85	>90	CRBN	[1]
11o	A549	7.53	>90	CRBN	[1]
P7	SW620	590	87	CRBN	[17]
SIAIS562055	K562	~100-1000	>80	CRBN	[18]

DC_{50} : Half-maximal degradation concentration. D_{max} : Maximum degradation.

Table 2: Anti-proliferative Activity (IC_{50})

PROTAC	Cell Line	IC ₅₀ (nM)	Reference
11o	SW620	10.3	[1]
11o	A549	25.6	[1]
P7	SW620	>10,000	[17]
SIAIS562055	K562	~100-1000	[18]

IC₅₀: Half-maximal inhibitory concentration.

Conclusion

This guide provides a foundational framework for the synthesis and evaluation of SOS1 PROTACs. The modular nature of PROTAC synthesis allows for the systematic optimization of warheads, linkers, and E3 ligase ligands to achieve potent and selective degradation of SOS1. The provided protocols and data serve as a valuable resource for researchers aiming to develop novel therapeutics for KRAS-driven cancers. Further optimization and in vivo studies are necessary to translate these promising molecules into clinical candidates.

Need Custom Synthesis?

BenchChem offers custom synthesis for rare earth carbides and specific isotopic labeling.

Email: info@benchchem.com or [Request Quote Online](#).

References

- 1. Design, synthesis, and bioevaluation of SOS1 PROTACs derived from pyrido[2,3-d]pyrimidin-7-one-based SOS1 inhibitor - PubMed [pubmed.ncbi.nlm.nih.gov]
- 2. [benchchem.com](https://www.benchchem.com) [[benchchem.com](https://www.benchchem.com)]
- 3. [grokipedia.com](https://www.grokipedia.com) [[grokipedia.com](https://www.grokipedia.com)]
- 4. Son of Sevenless - Wikipedia [en.wikipedia.org]
- 5. Mammalian Son of Sevenless Guanine Nucleotide Exchange Factors: Old Concepts and New Perspectives - PMC [pmc.ncbi.nlm.nih.gov]

- [6. Design, Synthesis, and Bioevaluation of Pyrido\[2,3-d\]pyrimidin-7-ones as Potent SOS1 Inhibitors - PMC \[pmc.ncbi.nlm.nih.gov\]](#)
- [7. Design, synthesis and biological evaluation of quinazoline SOS1 inhibitors - PubMed \[pubmed.ncbi.nlm.nih.gov\]](#)
- [8. benchchem.com \[benchchem.com\]](#)
- [9. Impact of Linker Composition on VHL PROTAC Cell Permeability - PMC \[pmc.ncbi.nlm.nih.gov\]](#)
- [10. medchemexpress.com \[medchemexpress.com\]](#)
- [11. benchchem.com \[benchchem.com\]](#)
- [12. researchgate.net \[researchgate.net\]](#)
- [13. Quinazoline-based multi-tyrosine kinase inhibitors: synthesis, modeling, antitumor and antiangiogenic properties - PubMed \[pubmed.ncbi.nlm.nih.gov\]](#)
- [14. researchgate.net \[researchgate.net\]](#)
- [15. Solid-phase synthesis for thalidomide-based proteolysis-targeting chimeras \(PROTAC\) - Chemical Communications \(RSC Publishing\) \[pubs.rsc.org\]](#)
- [16. Factors to Consider for Synthesis in 1536-Well Plates—An Amide Coupling Case Study for PROTAC Synthesis - PMC \[pmc.ncbi.nlm.nih.gov\]](#)
- [17. Development of SOS1 inhibitor-based degraders to target KRAS-mutant colorectal cancer - PMC \[pmc.ncbi.nlm.nih.gov\]](#)
- [18. aacrjournals.org \[aacrjournals.org\]](#)
- To cite this document: BenchChem. [Step-by-step guide to synthesizing SOS1 PROTACs using intermediates]. BenchChem, [2026]. [Online PDF]. Available at: [\[https://www.benchchem.com/product/b15613269/docs#step-by-step-guide-to-synthesizing-sos1-protacs-using-intermediates\]](https://www.benchchem.com/product/b15613269/docs#step-by-step-guide-to-synthesizing-sos1-protacs-using-intermediates)

Disclaimer & Data Validity:

The information provided in this document is for Research Use Only (RUO) and is strictly not intended for diagnostic or therapeutic procedures. While BenchChem strives to provide accurate protocols, we make no warranties, express or implied, regarding the fitness of this product for every specific experimental setup.

Technical Support: The protocols provided are for reference purposes. Unsure if this reagent suits your experiment?

Need Industrial/Bulk Grade? [Request Custom Synthesis Quote](#)

BenchChem

Our mission is to be the trusted global source of essential and advanced chemicals, empowering scientists and researchers to drive progress in science and industry.

Contact

Address: 3281 E Guasti Rd
Ontario, CA 91761, United States
Phone: (601) 213-4426
Email: info@benchchem.com

[Contact our Ph.D. Support Team for a compatibility check](#)