

Psma-IN-3 protocol modifications for different cell lines

Author: BenchChem Technical Support Team. **Date:** April 2026

Compound of Interest

Compound Name: *Psma-IN-3*

Cat. No.: *B15613245*

[Get Quote](#)

Technical Support Center: Psma-IN-3

This technical support center provides troubleshooting guides and frequently asked questions (FAQs) for researchers utilizing **Psma-IN-3**, a novel inhibitor of Prostate-Specific Membrane Antigen (PSMA). The following information is designed to assist in the adaptation of the **Psma-IN-3** protocol for various cell lines.

Frequently Asked Questions (FAQs)

Q1: Which cell lines are most suitable for studying the effects of **Psma-IN-3**?

A1: The choice of cell line is critical and depends on the specific research question. Prostate cancer cell lines are commonly used and exhibit varying levels of PSMA expression. LNCaP and C4-2 cells show high endogenous PSMA expression, making them suitable for studying the direct effects of **Psma-IN-3**. PC-3 and DU-145 cells have low to negligible PSMA expression and can serve as excellent negative controls. For studies involving engineered expression, PC-3 cells are often used to create stable cell lines overexpressing PSMA (e.g., PC3-PIP).

Q2: What is the general mechanism of action of PSMA and how does **Psma-IN-3** likely work?

A2: PSMA is a transmembrane protein with enzymatic activity that plays a significant role in prostate cancer progression. It is known to modulate cell survival signaling pathways. Notably, PSMA can redirect signaling from the MAPK/ERK pathway towards the PI3K/Akt survival pathway.[1][2] **Psma-IN-3** is designed as a small molecule inhibitor that likely targets the enzymatic activity of PSMA, thereby preventing this signaling switch and promoting apoptosis or inhibiting proliferation in PSMA-expressing cancer cells.

Q3: What are the recommended starting concentrations and incubation times for **Psma-IN-3**?

A3: For initial experiments, a dose-response study is recommended to determine the optimal concentration for your specific cell line. Based on common small molecule inhibitors, a starting range of 10 nM to 10 μ M is advisable. Incubation times can vary from 24 to 72 hours, depending on the assay and the expected biological outcome (e.g., apoptosis, inhibition of proliferation).

Q4: How can I verify that my cell line expresses PSMA?

A4: PSMA expression can be confirmed using several standard molecular biology techniques. Western blotting can be used to detect the total PSMA protein level within the cell lysate. Flow cytometry is ideal for quantifying the level of PSMA on the cell surface, which is crucial for the action of extracellularly targeting inhibitors like **Psma-IN-3**. Quantitative reverse transcription PCR (qRT-PCR) can be used to measure the mRNA expression level of the FOLH1 gene, which encodes for PSMA.

Troubleshooting Guide

Issue	Potential Cause	Recommended Solution
<p>Low or no observable effect of Psma-IN-3 on a supposedly PSMA-positive cell line (e.g., LNCaP).</p>	<p>1. Low passage number of cells may have altered PSMA expression. 2. Incorrect concentration of Psma-IN-3 used. 3. Insufficient incubation time. 4. Degradation of the Psma-IN-3 compound.</p>	<p>1. Use cells within a consistent and validated passage number range. Regularly check PSMA expression via Western blot or flow cytometry. 2. Perform a dose-response experiment to determine the IC50 for your specific cell line. 3. Increase the incubation time (e.g., from 24h to 48h or 72h). 4. Ensure proper storage of the compound as per the manufacturer's instructions. Prepare fresh dilutions for each experiment.</p>
<p>High background or off-target effects observed in PSMA-negative cell lines (e.g., PC-3).</p>	<p>1. The observed effect may be independent of PSMA inhibition. 2. High concentrations of Psma-IN-3 may lead to non-specific toxicity.</p>	<p>1. Investigate alternative mechanisms of action or potential off-target binding. 2. Use the lowest effective concentration determined from your dose-response studies in PSMA-positive cells.</p>
<p>Inconsistent results between experimental replicates.</p>	<p>1. Variability in cell seeding density. 2. Inconsistent timing of Psma-IN-3 addition. 3. Edge effects in multi-well plates.</p>	<p>1. Ensure a uniform single-cell suspension and accurate cell counting before seeding. 2. Add the inhibitor at the same time point after cell seeding for all replicates. 3. Avoid using the outer wells of multi-well plates for treatment groups, or fill them with media to maintain humidity.</p>
<p>Difficulty in detecting changes in downstream signaling</p>	<p>1. Timing of cell lysis after treatment is not optimal. 2.</p>	<p>1. Perform a time-course experiment to identify the peak</p>

<p>pathways (e.g., p-Akt, p-ERK).</p>	<p>Low abundance of target proteins. 3. Issues with antibody quality for Western blotting.</p>	<p>time for signaling changes after Psma-IN-3 treatment. 2. Increase the amount of protein loaded for Western blotting. 3. Validate antibodies using positive and negative controls.</p>
---------------------------------------	--	--

Quantitative Data Summary

Table 1: Relative PSMA Expression in Common Prostate Cancer Cell Lines

Cell Line	PSMA Expression Level	Typical Use Case
LNCaP	High	Positive control, endogenous expression studies
C4-2	High	Positive control, castration-resistant model
22Rv1	Moderate to High	Positive control, expresses AR-V7
PC-3	Very Low / Negative	Negative control, suitable for overexpression studies
DU-145	Very Low / Negative	Negative control

This table provides a general guide. It is recommended to verify PSMA expression in your specific cell line and passage number.

Table 2: Example Dose-Response Data for **Psma-IN-3** in LNCaP cells after 48h Treatment

Psma-IN-3 Concentration (μM)	% Inhibition of Cell Viability (Mean \pm SD)
0.01	5.2 \pm 1.8
0.1	22.5 \pm 3.1
1	48.9 \pm 4.5
10	85.1 \pm 2.9
100	95.7 \pm 1.5

Data are hypothetical and for illustrative purposes only. Actual results will vary depending on experimental conditions.

Experimental Protocols

General Protocol for Assessing Cell Viability with **Psma-IN-3**

- Cell Seeding:
 - Culture cells to ~80% confluency.
 - Trypsinize and neutralize, then count the cells using a hemocytometer or automated cell counter.
 - Seed the cells in a 96-well plate at a predetermined density (e.g., 5,000 cells/well for LNCaP).
 - Incubate for 24 hours to allow for cell attachment.
- **Psma-IN-3** Treatment:
 - Prepare a series of dilutions of **Psma-IN-3** in your cell culture medium.
 - Carefully remove the old medium from the wells and replace it with the medium containing the different concentrations of **Psma-IN-3**. Include a vehicle-only control.
 - Incubate for the desired period (e.g., 48 hours).

- Cell Viability Assay (e.g., using a resazurin-based reagent):
 - Add the viability reagent to each well according to the manufacturer's instructions.
 - Incubate for 1-4 hours.
 - Measure the fluorescence or absorbance using a plate reader.
- Data Analysis:
 - Subtract the background reading from all wells.
 - Normalize the data to the vehicle-only control to determine the percentage of viability.
 - Plot the percentage of inhibition versus the log of the **Psma-IN-3** concentration to determine the IC50 value.

Visualizations

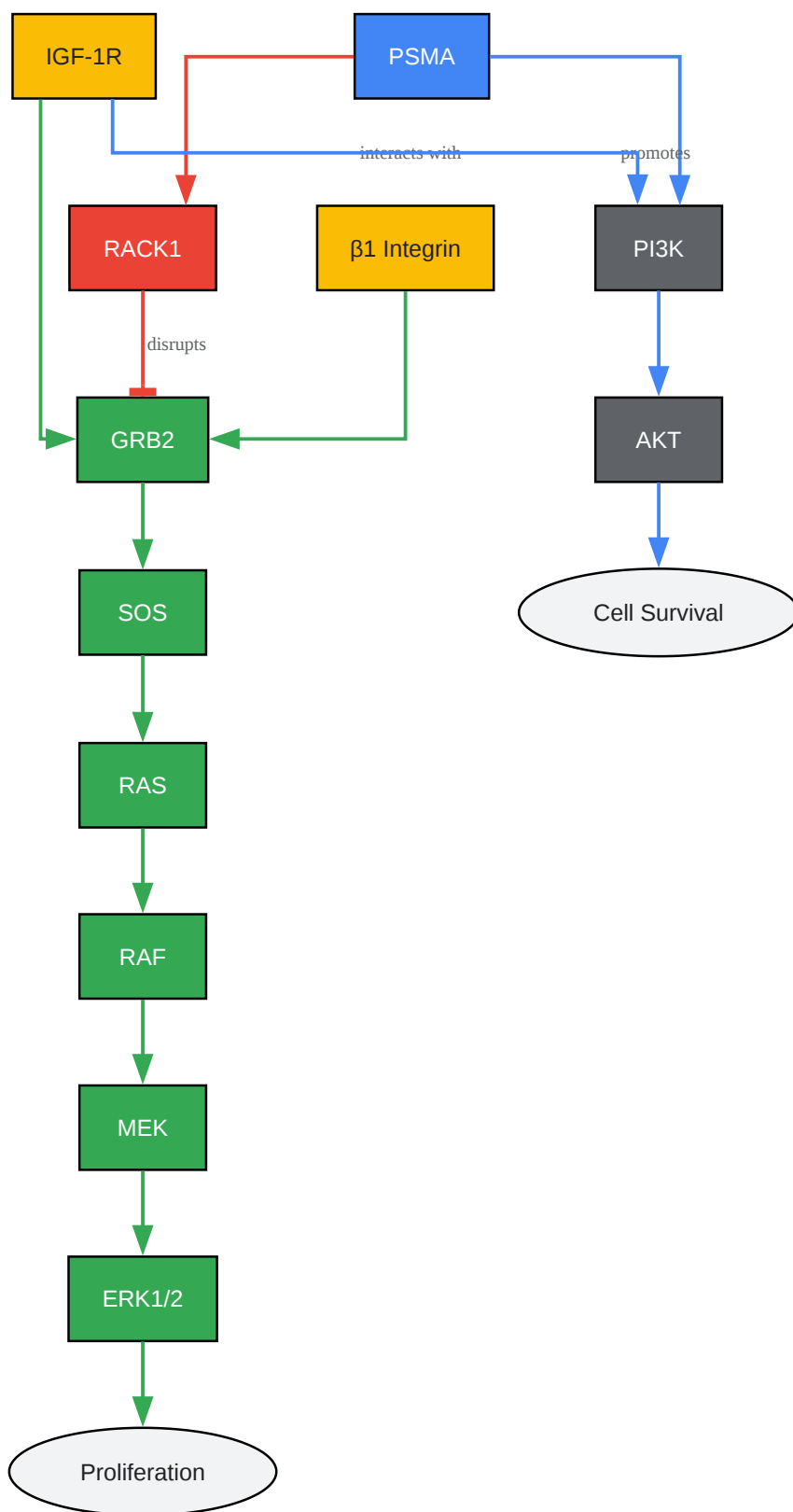

[Click to download full resolution via product page](#)

Caption: PSMA signaling redirects from MAPK/ERK to PI3K/Akt pathway.

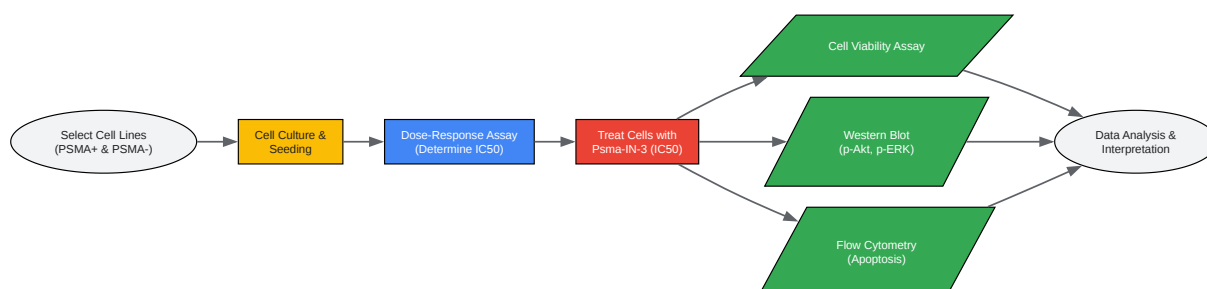

[Click to download full resolution via product page](#)

Caption: General workflow for in vitro testing of **Psma-IN-3**.

Need Custom Synthesis?

BenchChem offers custom synthesis for rare earth carbides and specific isotopic labeling.

Email: info@benchchem.com or [Request Quote Online](#).

References

- 1. PSMA redirects cell survival signaling from the MAPK to the PI3K-AKT pathways to promote the progression of prostate cancer - PMC [[pmc.ncbi.nlm.nih.gov](https://pubmed.ncbi.nlm.nih.gov/)]
- 2. urotoday.com [urotoday.com]
- To cite this document: BenchChem. [Psma-IN-3 protocol modifications for different cell lines]. BenchChem, [2026]. [Online PDF]. Available at: [<https://www.benchchem.com/product/b15613245/docs#psma-in-3-protocol-modifications-for-different-cell-lines>]

Disclaimer & Data Validity:

The information provided in this document is for Research Use Only (RUO) and is strictly not intended for diagnostic or therapeutic procedures. While BenchChem strives to provide accurate protocols, we make no warranties, express or implied, regarding the fitness of this product for every specific experimental setup.

Technical Support: The protocols provided are for reference purposes. Unsure if this reagent suits your experiment?

Need Industrial/Bulk Grade? [Request Custom Synthesis Quote](#)

BenchChem

Our mission is to be the trusted global source of essential and advanced chemicals, empowering scientists and researchers to drive progress in science and industry.

Contact

Address: 3281 E Guasti Rd
Ontario, CA 91761, United States
Phone: (601) 213-4426
Email: info@benchchem.com

[Contact our Ph.D. Support Team for a compatibility check](#)