

Interpreting unexpected data from ES-072 experiments

Author: BenchChem Technical Support Team. **Date:** April 2026

Compound of Interest

Compound Name: ES-072
Cat. No.: B15613332

[Get Quote](#)

ES-072 Technical Support Center

Welcome to the technical support center for **ES-072**. This resource is designed for researchers, scientists, and drug development professionals to help interpret unexpected data and troubleshoot experiments involving **ES-072**.

Frequently Asked Questions (FAQs)

Q1: What is the primary mechanism of action for **ES-072**?

A1: **ES-072** is a third-generation epidermal growth factor receptor (EGFR) inhibitor.[1][2] Uniquely, it also promotes the proteasomal degradation of Programmed death-ligand 1 (PD-L1).[1] This dual action allows it to both suppress tumor cell proliferation and enhance anti-tumor immunity.[1]

Q2: In which cancer cell lines has **ES-072** shown activity?

A2: **ES-072** has demonstrated significant activity in multiple cancer cell lines, including U937, H1975, and HEK293T, by reducing membrane PD-L1 expression.[1]

Q3: What is the expected in vivo effect of **ES-072**?

A3: In vivo, **ES-072** treatment has been shown to markedly inhibit tumor growth and increase the infiltration of CD8+ cytotoxic T-cells in BALB/c mouse models.[1]

Q4: How does **ES-072** induce PD-L1 degradation?

A4: **ES-072** suppresses AKT signaling, which leads to the activation of GSK3 α . [1] Activated GSK3 α phosphorylates PD-L1 at Ser279 and Ser283. [1] This phosphorylation event recruits the E3 ubiquitin ligase ARIH1, which then triggers K48-linked ubiquitination and subsequent proteasome-mediated degradation of PD-L1. [1]

Troubleshooting Guides

Issue 1: No significant decrease in cell viability observed after **ES-072** treatment.

Possible Causes and Troubleshooting Steps:

- Cell Line Resistance: The cell line used may have intrinsic resistance to EGFR inhibitors.
 - Action: Confirm the EGFR mutation status of your cell line. **ES-072** is particularly effective against EGFR T790M mutations. [2] Consider using a positive control cell line known to be sensitive to **ES-072**, such as H1975.
- Incorrect Dosing: The concentration of **ES-072** may be too low.
 - Action: Perform a dose-response experiment to determine the optimal concentration for your specific cell line. The reported IC₅₀ for EGFR T790M/L858R is less than 1 nM. [1]
- Assay Issues: The cell viability assay may not be sensitive enough or may have been performed incorrectly.
 - Action: Ensure the viability assay is suitable for your experimental setup and that the incubation times are appropriate. Consider using a multiplex approach that combines different viability indicators.

Issue 2: No significant reduction in PD-L1 expression levels.

Possible Causes and Troubleshooting Steps:

- **Compromised Signaling Pathway:** Components of the AKT/GSK3 α /ARIH1 pathway may be altered in your cell line, preventing PD-L1 degradation.
 - **Action:** Verify the expression and activity of key proteins in this pathway (AKT, GSK3 α , ARIH1) using techniques like Western blotting.
- **Proteasome Inhibition:** If other proteasome inhibitors are used in your experimental setup, they could interfere with **ES-072**'s mechanism of action.
 - **Action:** Review your experimental protocol to ensure no conflicting reagents are present. The effect of **ES-072** on PD-L1 expression is blocked by the proteasome inhibitor MG132. [\[1\]](#)
- **Incorrect timing of measurement:** PD-L1 degradation is a dynamic process.
 - **Action:** Perform a time-course experiment to identify the optimal time point for observing PD-L1 reduction after **ES-072** treatment.

Data Presentation

Table 1: In Vitro Efficacy of **ES-072**

Target	Cell Lines	Metric	Value	Reference
EGFR (T790M/L858R)	Not specified	IC ₅₀	< 1 nM	[1]
PD-L1 Expression	U937, H1975, HEK293T	Outcome	Significant Reduction	[1]

Table 2: Clinical Pharmacokinetics of **ES-072** (Phase 1)

Parameter	Value
Half-life ($t_{1/2}$)	24.5 hours
Time to maximum concentration (T_{max})	~4 hours

Experimental Protocols

Protocol 1: Cell Viability Assay

This protocol is a general guideline and should be optimized for your specific cell line and experimental conditions.

- Cell Plating:
 - Seed cells in a 96-well plate at a density of 5,000-10,000 cells per well.
 - Incubate for 24 hours to allow for cell attachment.
- **ES-072** Treatment:
 - Prepare a serial dilution of **ES-072** in complete growth medium.
 - Remove the old medium from the wells and add 100 μ L of the **ES-072** dilutions.
 - Include a vehicle control (e.g., DMSO) and a positive control.
 - Incubate for 72 hours.
- Viability Assessment:
 - Use a commercially available cell viability reagent (e.g., CellTiter-Glo®).
 - Follow the manufacturer's instructions to measure cell viability.
- Data Analysis:
 - Normalize the data to the vehicle control.

- Plot the dose-response curve and calculate the IC₅₀ value.

Protocol 2: Western Blot for PD-L1 Expression

- Cell Lysis:
 - Treat cells with **ES-072** at the desired concentration and for the optimal time.
 - Wash cells with ice-cold PBS and lyse them in RIPA buffer supplemented with protease and phosphatase inhibitors.
- Protein Quantification:
 - Determine the protein concentration of the lysates using a BCA assay.
- SDS-PAGE and Transfer:
 - Load equal amounts of protein onto an SDS-PAGE gel.
 - Separate the proteins by electrophoresis and transfer them to a PVDF membrane.
- Immunoblotting:
 - Block the membrane with 5% non-fat milk or BSA in TBST for 1 hour.
 - Incubate the membrane with a primary antibody against PD-L1 overnight at 4°C.
 - Wash the membrane and incubate with an HRP-conjugated secondary antibody for 1 hour at room temperature.
- Detection:
 - Detect the signal using an enhanced chemiluminescence (ECL) substrate and image the blot.
 - Use a loading control (e.g., β -actin or GAPDH) to ensure equal protein loading.

Visualizations

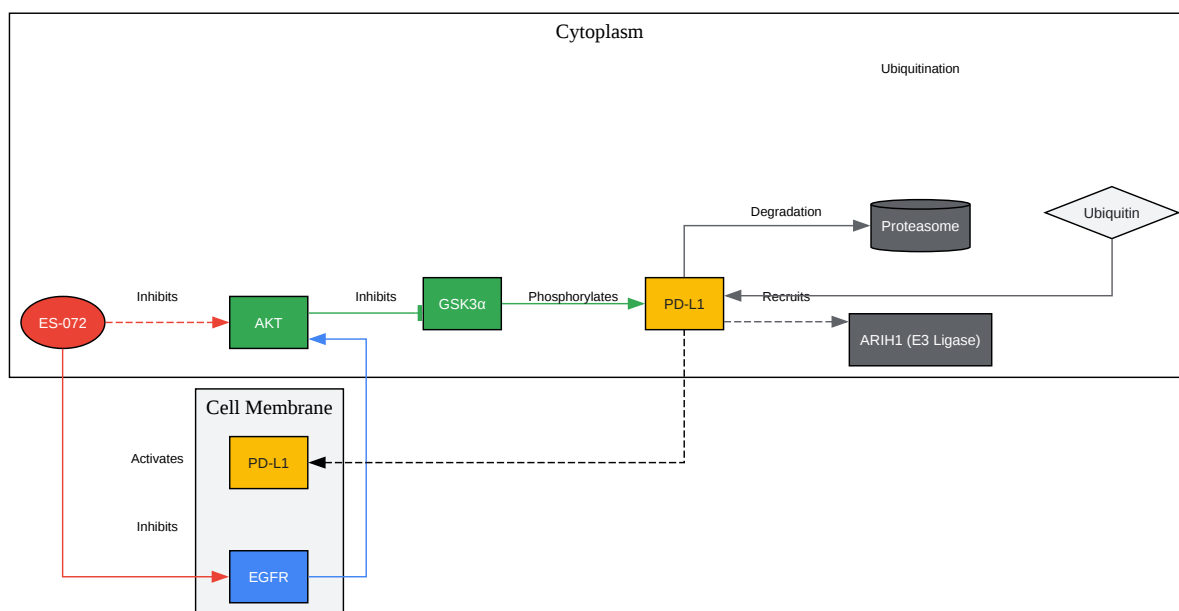

[Click to download full resolution via product page](#)

Caption: **ES-072** signaling pathway leading to PD-L1 degradation.

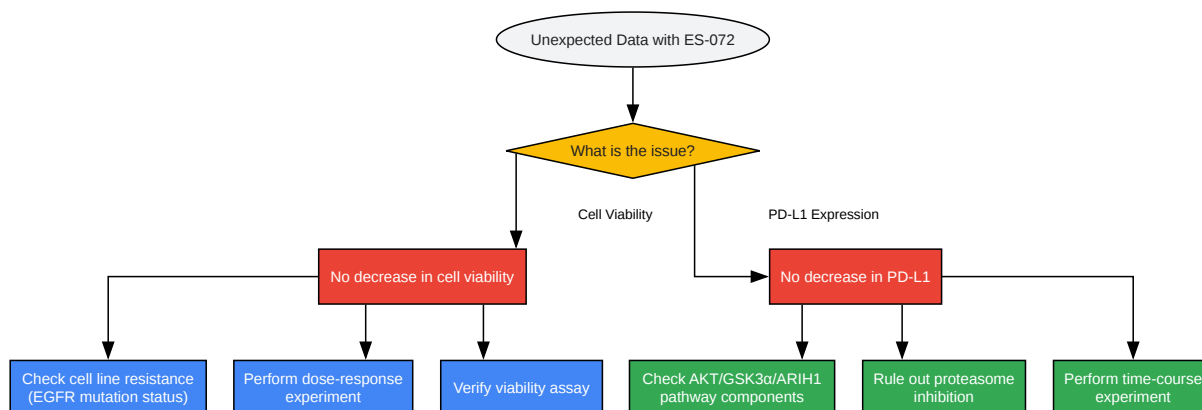

[Click to download full resolution via product page](#)

Caption: Troubleshooting flowchart for unexpected **ES-072** experimental results.

Need Custom Synthesis?

BenchChem offers custom synthesis for rare earth carbides and specific isotopic labeling.

Email: info@benchchem.com or [Request Quote Online](#).

References

- 1. cancer-research-network.com [cancer-research-network.com]
- 2. First-in-Human Phase 1 Study of ES-072, an Oral Mutant-Selective EGFR T790M Inhibitor, in Non-Small-Cell Lung Cancer - PubMed [pubmed.ncbi.nlm.nih.gov]
- To cite this document: BenchChem. [Interpreting unexpected data from ES-072 experiments]. BenchChem, [2026]. [Online PDF]. Available at: [https://www.benchchem.com/product/b15613332/docs#interpreting-unexpected-data-from-es-072-experiments]

Disclaimer & Data Validity:

The information provided in this document is for Research Use Only (RUO) and is strictly not intended for diagnostic or therapeutic procedures. While BenchChem strives to provide accurate protocols, we make no warranties, express or implied, regarding the fitness of this product for every specific experimental setup.

Technical Support: The protocols provided are for reference purposes. Unsure if this reagent suits your experiment?

Need Industrial/Bulk Grade? [Request Custom Synthesis Quote](#)

BenchChem

Our mission is to be the trusted global source of essential and advanced chemicals, empowering scientists and researchers to drive progress in science and industry.

Contact

Address: 3281 E Guasti Rd
Ontario, CA 91761, United States
Phone: (601) 213-4426
Email: info@benchchem.com

[Contact our Ph.D. Support Team for a compatibility check](#)