

validating the pro-myelinating effects of GPR17 modulator-1 using electron microscopy

Author: BenchChem Technical Support Team. **Date:** April 2026

Compound of Interest

Compound Name: GPR17 modulator-1

Cat. No.: B15612957

[Get Quote](#)

Validating Pro-Myelinating Effects of GPR17 Modulator-1: A Comparative Guide

For Researchers, Scientists, and Drug Development Professionals

This guide provides a comprehensive comparison of the pro-myelinating effects of a putative GPR17 antagonist, herein referred to as **GPR17 Modulator-1**, against alternative therapeutic compounds. The data presented is based on experimental findings from preclinical models, with a focus on quantitative analysis using electron microscopy. Detailed experimental protocols and visual representations of signaling pathways and workflows are included to support researchers in the field of neurodegenerative diseases and myelin repair.

Comparative Analysis of Pro-Myelinating Compounds

The G protein-coupled receptor 17 (GPR17) has been identified as a key negative regulator of oligodendrocyte differentiation and myelination. Its expression must be downregulated for oligodendrocyte precursor cells (OPCs) to mature into myelin-producing oligodendrocytes.^[1]

Consequently, antagonists of GPR17 are being investigated as potential therapeutic agents to promote remyelination in diseases such as multiple sclerosis.

This guide evaluates the efficacy of "**GPR17 Modulator-1**," a hypothetical potent GPR17 antagonist, by comparing its expected pro-myelinating effects with those of Clemastine, an antihistamine that promotes myelination through a GPR17-independent mechanism.^{[2][3][4]} The comparison is based on quantitative data from electron microscopy studies, focusing on key metrics of myelination.

Quantitative Data Summary

The following table summarizes the quantitative outcomes from preclinical studies evaluating the effects of GPR17 inhibition (via genetic knockout, serving as a proxy for a potent antagonist like **GPR17 Modulator-1**) and Clemastine treatment on myelination. The data is derived from studies using a mouse model of social isolation-induced myelination deficits for Clemastine and a developmental myelination model for the GPR17 knockout mice.

Parameter	Vehicle/Control	GPR17 Modulator-1 (proxy: GPR17 Knockout)	Clemastine	Experimental Model
Number of Myelinated Axons (per field of view)	422.1 ± 37.0	Significantly increased	570.8 ± 31.3	Social Isolation (Clemastine) / Developmental (GPR17 KO)
g-ratio (axon diameter / fiber diameter) (lower value = thicker myelin)	0.882 ± 0.003	Comparable to control in adults	0.854 ± 0.004	Social Isolation (Clemastine) / Developmental (GPR17 KO)
Myelin Sheath Thickness	Thinner in social isolation model	Not specified, but g-ratio is comparable in adults	Restored to levels of group-housed controls	Social Isolation (Clemastine) / Developmental (GPR17 KO)

Note: Data for **GPR17 Modulator-1** is inferred from studies on GPR17 knockout mice, which showed an early onset of myelination and a significant increase in the number of myelinated axons at an early developmental stage (P3). However, in adult GPR17 null mice, the g-ratio was comparable to wild-type controls.[1][5] Data for Clemastine is from a study in a mouse model of social isolation.[4]

Signaling Pathways and Experimental Workflow

To visually represent the mechanisms and methodologies discussed, the following diagrams have been generated using Graphviz.

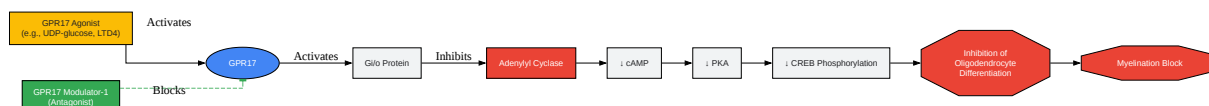

[Click to download full resolution via product page](#)

GPR17 Signaling Pathway in Oligodendrocytes.

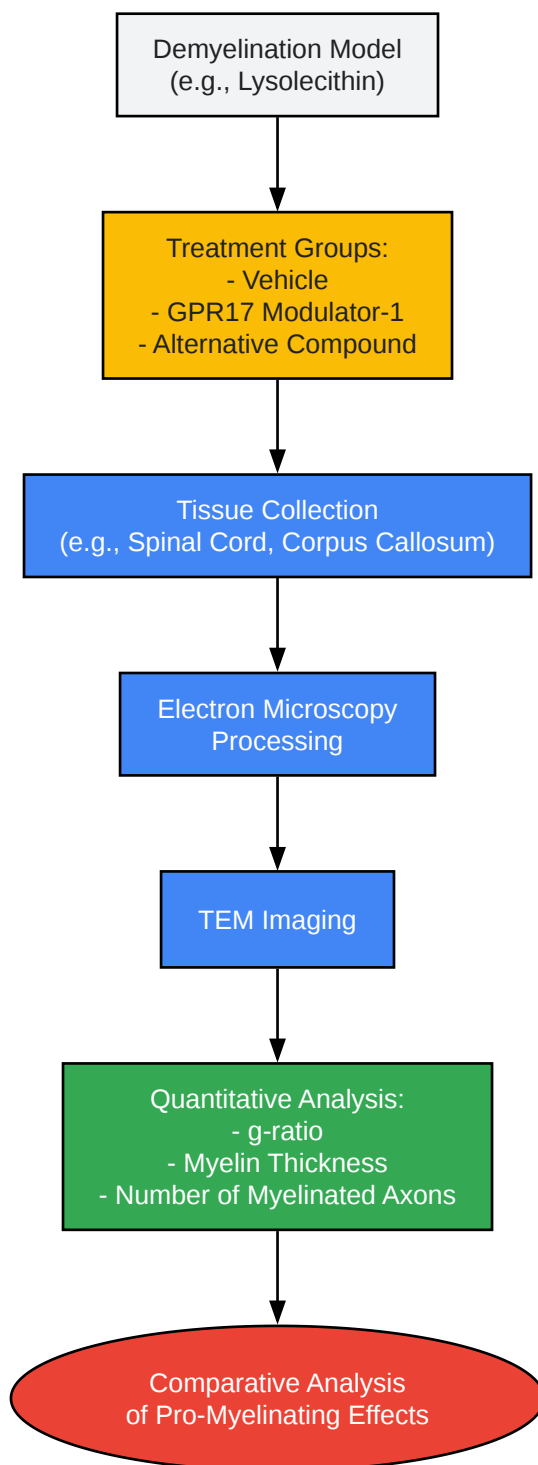

[Click to download full resolution via product page](#)

Workflow for Validating Pro-Myelinating Effects.

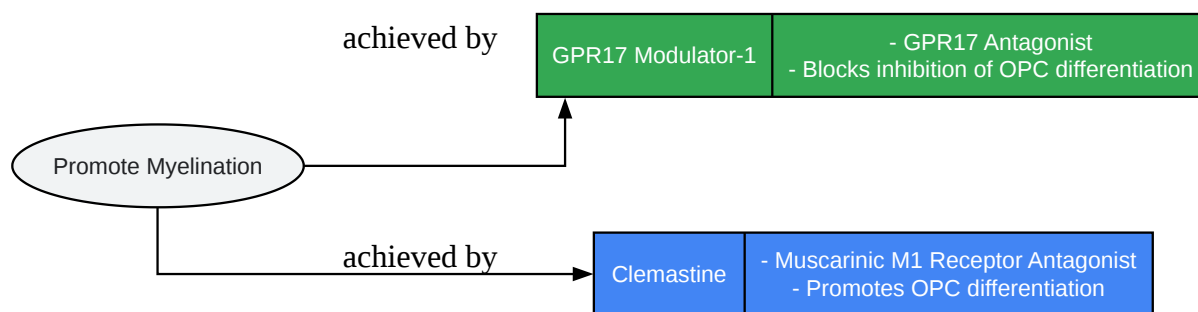

[Click to download full resolution via product page](#)

Logical Comparison of Pro-Myelinating Compounds.

Experimental Protocols

Protocol for Transmission Electron Microscopy (TEM)

Analysis of Myelination

This protocol details the steps for preparing and analyzing central nervous system (CNS) tissue to quantify myelination at the ultrastructural level.

1. Animal Perfusion and Tissue Fixation:

- Anesthetize the animal (e.g., mouse) with an appropriate anesthetic.
- Perform transcardial perfusion with a fixative solution containing 4% paraformaldehyde and 2.5% glutaraldehyde in 0.1 M sodium cacodylate buffer (pH 7.2).
- Dissect the CNS tissue of interest (e.g., optic nerve, corpus callosum, spinal cord) and immerse it in the same fixative solution overnight at 4°C.

2. Sample Processing and Embedding:

- Rinse the fixed tissue samples in phosphate-buffered saline (PBS).
- Post-fix the samples in 1% osmium tetroxide (OsO₄) in PBS for 1 hour.
- Dehydrate the samples through a graded series of ethanol concentrations.

- Infiltrate the tissue with propylene oxide.
 - Embed the samples in Epon resin and polymerize at 60°C for 48 hours.
3. Sectioning and Staining:
- Cut semi-thin sections (approximately 1 μm thick) using an ultramicrotome and stain with toluidine blue for initial light microscopy assessment.
 - Cut ultra-thin sections (70-90 nm thick) from the region of interest and mount them on copper grids.
 - Stain the ultra-thin sections with uranyl acetate and lead citrate to enhance contrast.
4. Imaging and Quantitative Analysis:
- Examine the stained sections using a transmission electron microscope.
 - Acquire images at various magnifications to visualize myelinated axons.
 - For quantitative analysis, randomly select fields of view and capture images at a magnification that allows for clear delineation of the axon and myelin sheath.
 - Use image analysis software (e.g., ImageJ) to measure:
 - Number of myelinated axons: Count all axons with a discernible myelin sheath in a defined area.
 - g-ratio: For each myelinated axon, measure the diameter of the axon and the total diameter of the fiber (axon + myelin). The g-ratio is the ratio of the axon diameter to the fiber diameter. A lower g-ratio indicates a thicker myelin sheath.
 - Myelin sheath thickness: This can be calculated from the g-ratio and axon diameter or measured directly.

Conclusion

The available data suggests that GPR17 antagonists, represented here by "**GPR17 Modulator-1**," hold promise as pro-myelinating agents by promoting an increase in the number of myelinated axons, particularly during the early stages of myelination or remyelination.[1][5] In comparison, Clemastine, acting through a different pathway, has been shown to not only increase the number of myelinated axons but also to improve myelin thickness in a model of chronic myelination deficit.[4]

The validation of any novel pro-myelinating compound requires rigorous quantitative analysis. The use of transmission electron microscopy, as detailed in the provided protocol, is the gold standard for obtaining precise measurements of myelination parameters. This guide serves as a foundational resource for researchers aiming to objectively assess and compare the efficacy of new therapeutic candidates for demyelinating diseases.

Need Custom Synthesis?

BenchChem offers custom synthesis for rare earth carbides and specific isotopic labeling.

Email: info@benchchem.com or [Request Quote Online](#).

References

- [1. The oligodendrocyte-specific G-protein coupled receptor GPR17 is a cell-intrinsic timer of myelination - PMC \[pmc.ncbi.nlm.nih.gov\]](#)
- [2. researchgate.net \[researchgate.net\]](#)
- [3. researchgate.net \[researchgate.net\]](#)
- [4. researchgate.net \[researchgate.net\]](#)
- [5. researchgate.net \[researchgate.net\]](#)
- To cite this document: BenchChem. [validating the pro-myelinating effects of GPR17 modulator-1 using electron microscopy]. BenchChem, [2026]. [Online PDF]. Available at: [<https://www.benchchem.com/product/b15612957/docs#validating-the-pro-myelinating-effects-of-gpr17-modulator-1-using-electron-microscopy>]

Disclaimer & Data Validity:

The information provided in this document is for Research Use Only (RUO) and is strictly not intended for diagnostic or therapeutic procedures. While BenchChem strives to provide accurate protocols, we make no warranties, express or implied, regarding the fitness of this product for every specific experimental setup.

Technical Support: The protocols provided are for reference purposes. Unsure if this reagent suits your experiment?

Need Industrial/Bulk Grade? [Request Custom Synthesis Quote](#)

BenchChem

Our mission is to be the trusted global source of essential and advanced chemicals, empowering scientists and researchers to drive progress in science and industry.

Contact

Address: 3281 E Guasti Rd
Ontario, CA 91761, United States
Phone: (601) 213-4426
Email: info@benchchem.com

[Contact our Ph.D. Support Team for a compatibility check](#)