

Validating GPR17 as the Primary Target of GPR17 Modulators: A Comparative Guide

Author: BenchChem Technical Support Team. **Date:** April 2026

Compound of Interest

Compound Name: GPR17 modulator-1

Cat. No.: B15612957

[Get Quote](#)

For Researchers, Scientists, and Drug Development Professionals

This guide provides an objective comparison of GPR17 modulators, focusing on the validation of GPR17 as their primary target. Experimental data and detailed methodologies are presented to support the comparative analysis, enabling researchers to make informed decisions in their drug discovery and development efforts. As "**GPR17 modulator-1**" is not a specifically identified compound in publicly available literature, this guide will focus on the well-characterized synthetic agonist MDL29,951 and the widely studied antagonists Pranlukast and Montelukast, comparing them with endogenous ligands.

GPR17 Signaling Pathways

GPR17 is a G protein-coupled receptor (GPCR) that is phylogenetically related to both the P2Y purinergic receptors and the cysteinyl leukotriene (CysLT) receptors.^[1] This dual nature is reflected in its response to two distinct families of endogenous ligands: uracil nucleotides (e.g., UDP, UDP-glucose) and cysteinyl leukotrienes (e.g., LTC4, LTD4).^{[1][2]} Upon activation, GPR17 can couple to multiple G protein subtypes, primarily Gai/o and Gαq, leading to downstream signaling cascades that regulate intracellular cyclic AMP (cAMP) levels and

calcium mobilization, respectively.[3][4] The receptor also undergoes β -arrestin recruitment, a key mechanism in GPCR desensitization and signaling.[3]

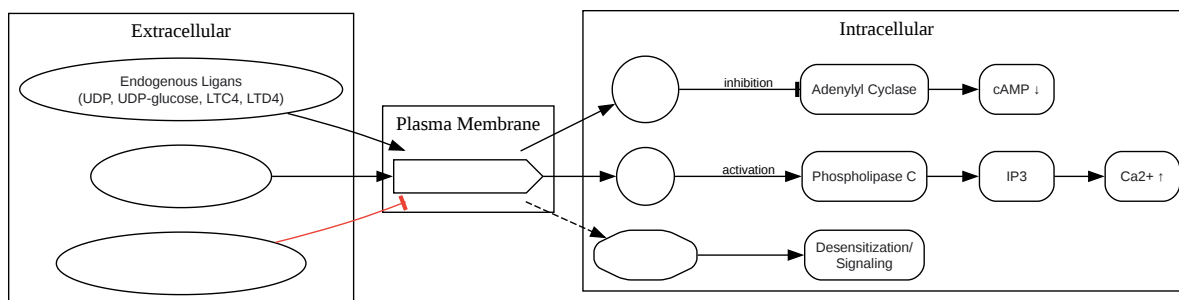

[Click to download full resolution via product page](#)

GPR17 Signaling Cascade.

Comparative Analysis of GPR17 Modulators

The validation of a compound's activity at GPR17 involves determining its potency and efficacy in various functional assays. The following tables summarize the quantitative data for selected GPR17 modulators.

Table 1: Potency (EC50) of GPR17 Agonists

Compound	Assay Type	Cell Line	EC50	Reference(s)
MDL29,951	cAMP Inhibition	GLUTag (hGPR17L)	12 μ M	[5]
cAMP Inhibition	LN229	16.62 μ M	[6]	
cAMP Inhibition	SNB19	17.73 μ M	[6]	
Calcium Mobilization	LN229	41.93 μ M	[6]	
Calcium Mobilization	SNB19	26.33 μ M	[6]	
LTD4	[35S]GTPyS Binding	1321N1 (hGPR17)	nM range	[1]
UDP	[35S]GTPyS Binding	1321N1 (hGPR17)	μ M range	[1]
UDP-glucose	[35S]GTPyS Binding	1321N1 (hGPR17)	μ M range	[2]

Table 2: Potency (IC50) of GPR17 Antagonists

Compound	Assay Type	Cell Line	IC50	Reference(s)
Pranlukast	GPR17 Antagonism	ATDC5	Not specified	[7]
Montelukast	CysLT1 Antagonism	HEK293 (hCysLT1)	4.9 nM	[8]
HAMI3379	β -arrestin Recruitment	PathHunter GPR17	8.2 μ M	[9]
Calcium Mobilization	1321N1 (hGPR17)	8.1 μ M	[9]	
cAMP Inhibition	1321N1 (hGPR17)	1.5 μ M	[9]	

Note: Direct IC50 values for Pranlukast and Montelukast at GPR17 are not consistently reported in the literature, as they are primarily characterized as CysLT1 receptor antagonists that also exhibit activity at GPR17.

Experimental Workflow for GPR17 Target Validation

The process of validating GPR17 as the primary target of a novel modulator involves a series of in vitro assays to characterize its binding and functional activity. A typical workflow is outlined below.

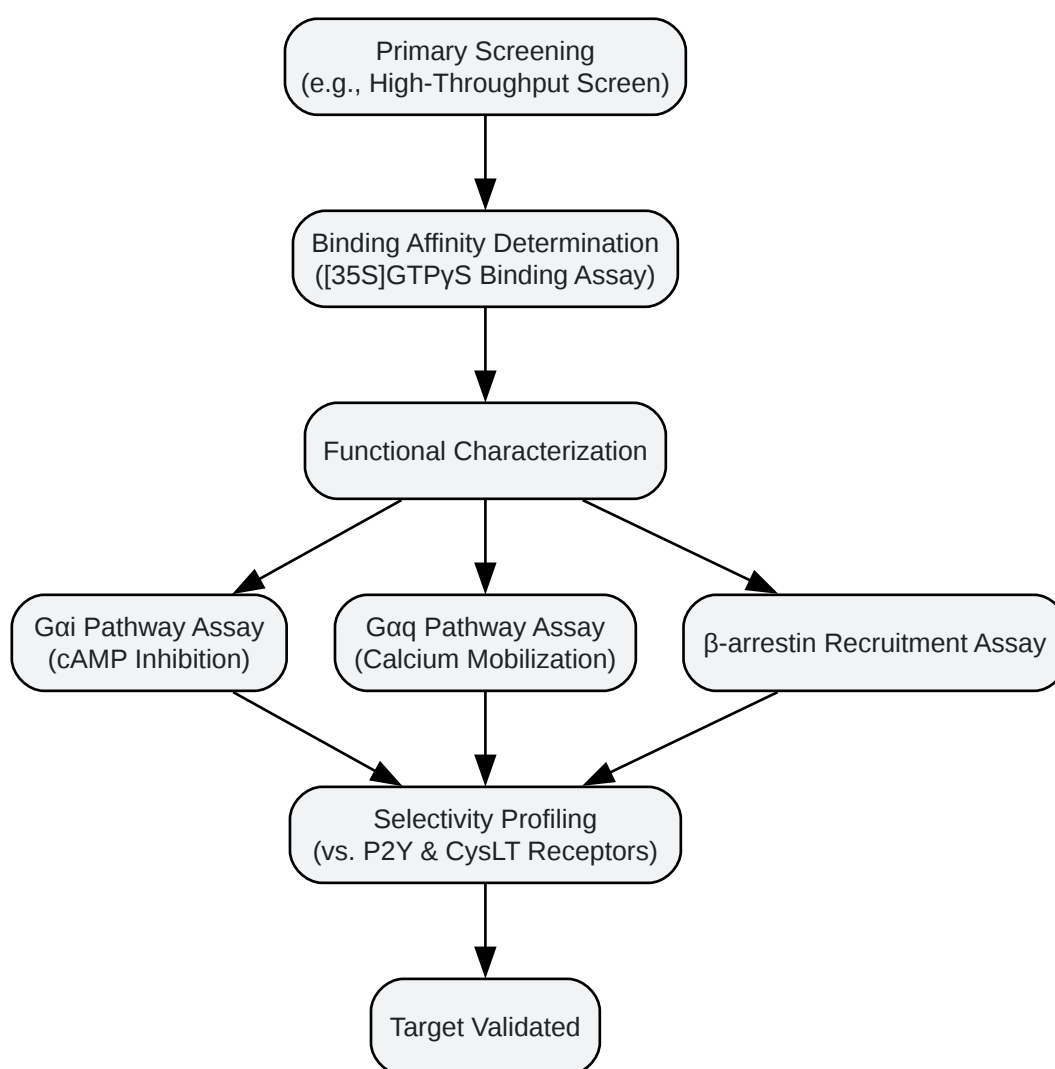

[Click to download full resolution via product page](#)

Workflow for Validating a Novel GPR17 Modulator.

Detailed Experimental Protocols

[³⁵S]GTPγS Binding Assay

This assay measures the functional consequence of receptor activation at the G protein level by quantifying the binding of the non-hydrolyzable GTP analog, [³⁵S]GTPγS, to activated Gα subunits.

- Cell Membrane Preparation:
 - Culture cells stably expressing human GPR17 (e.g., 1321N1 astrocytoma cells) to confluency.
 - Harvest cells and homogenize in ice-cold TME buffer (50 mM Tris-HCl, 1 mM EDTA, 5 mM MgCl₂, pH 7.4).
 - Centrifuge the homogenate at 48,000 x g for 15 minutes at 4°C.
 - Resuspend the membrane pellet in assay buffer (50 mM Tris-HCl, 100 mM NaCl, 5 mM MgCl₂, 1 mM EDTA, pH 7.4) and determine protein concentration.
- Assay Procedure:
 - In a 96-well plate, add cell membranes (10-20 μg protein/well), GDP (10 μM final concentration), and varying concentrations of the test compound (agonist or antagonist).
 - For antagonist evaluation, pre-incubate the membranes with the antagonist before adding a fixed concentration of a known agonist.
 - Initiate the binding reaction by adding [³⁵S]GTPγS (0.05-0.1 nM final concentration).
 - Incubate the plate at 30°C for 60 minutes with gentle shaking.
 - Terminate the reaction by rapid filtration through GF/B filter plates using a cell harvester.
 - Wash the filters three times with ice-cold wash buffer (50 mM Tris-HCl, pH 7.4).
 - Dry the filter plates, add scintillation cocktail, and quantify radioactivity using a microplate scintillation counter.

- Non-specific binding is determined in the presence of a high concentration of unlabeled GTPγS (10 μM).

cAMP Accumulation Assay

This assay determines the effect of GPR17 modulation on the intracellular levels of cyclic AMP, typically through the Gαi signaling pathway which inhibits adenylyl cyclase.

- Cell Preparation:
 - Seed cells expressing GPR17 (e.g., CHO-K1 or HEK293) in a 384-well plate and culture overnight.
 - For assays using a cAMP biosensor like GloSensor™, transfect the cells with the biosensor plasmid 24-48 hours prior to the assay.
- Assay Procedure (using GloSensor™):
 - Remove the culture medium and add the GloSensor™ cAMP Reagent equilibration medium.
 - Incubate for 2 hours at room temperature to allow substrate to enter the cells.
 - Measure the basal luminescence signal.
 - Add varying concentrations of the test compound. For antagonist testing, pre-incubate with the antagonist before adding an agonist.
 - Stimulate adenylyl cyclase with forskolin (1-10 μM) to induce cAMP production.
 - Measure the luminescence signal kinetically over 15-30 minutes. A decrease in the forskolin-stimulated signal indicates Gαi activation.[\[10\]](#)[\[11\]](#)

Calcium Mobilization Assay

This assay measures changes in intracellular calcium concentration, which is mediated by the Gαq pathway leading to the release of calcium from intracellular stores.

- Cell Preparation and Dye Loading:
 - Seed cells expressing GPR17 (e.g., HEK293T co-transfected with a promiscuous G α subunit like G α 16) in a 96-well black-walled, clear-bottom plate.
 - Culture overnight.
 - Remove the culture medium and load the cells with a calcium-sensitive fluorescent dye (e.g., Fluo-4 AM) in assay buffer for 30-60 minutes at 37°C.
- Assay Procedure:
 - After dye loading, wash the cells with assay buffer.
 - Place the plate in a fluorescence plate reader (e.g., FLIPR or FlexStation).
 - Measure the basal fluorescence intensity.
 - Add varying concentrations of the test compound and immediately measure the change in fluorescence intensity over time (typically 1-3 minutes). An increase in fluorescence indicates calcium mobilization.[\[12\]](#)[\[13\]](#)

β -Arrestin Recruitment Assay

This assay measures the recruitment of β -arrestin to the activated GPR17, a key event in receptor desensitization and signaling.

- Assay Principle (e.g., PathHunter® Assay):
 - Use a cell line engineered to co-express GPR17 fused to a ProLink™ (PK) tag and β -arrestin fused to an Enzyme Acceptor (EA) tag.
 - Ligand-induced activation of GPR17-PK recruits β -arrestin-EA.
 - The proximity of PK and EA allows for the complementation of a β -galactosidase enzyme.
 - The active enzyme hydrolyzes a substrate to produce a chemiluminescent signal.
- Assay Procedure:

- Plate the PathHunter® GPR17 β -arrestin cells in a 384-well white-walled plate and culture overnight.
- Add varying concentrations of the test compound. For antagonist mode, pre-incubate with the antagonist.
- For antagonist mode, add an EC80 concentration of a known agonist (e.g., MDL29,951).
- Incubate the plate at 37°C for 90 minutes.
- Add the detection reagent and incubate for 60 minutes at room temperature.
- Measure the chemiluminescent signal using a plate reader.[3][14]

Logical Framework for Comparative Evaluation

The validation of a modulator's primary target as GPR17 relies on a logical framework that integrates data from multiple assays. This framework helps to distinguish specific on-target effects from off-target activities.

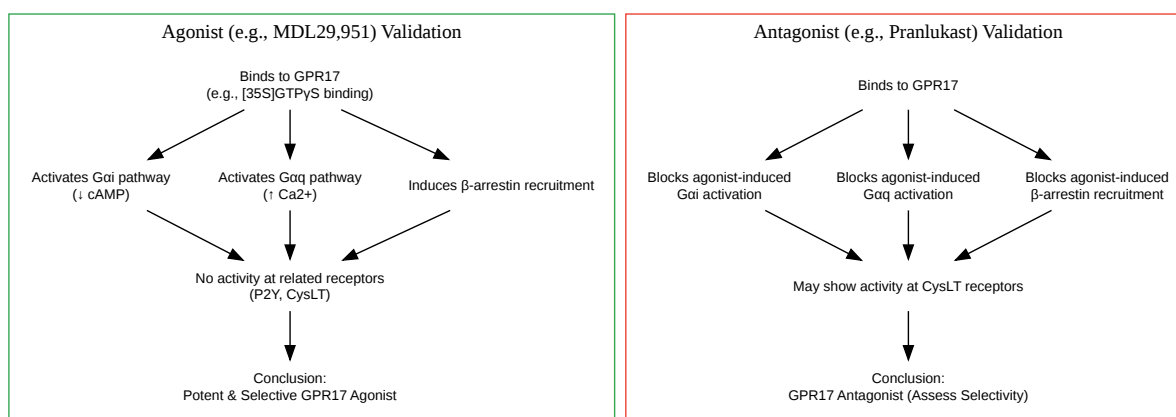

[Click to download full resolution via product page](#)

Logical Framework for Modulator Validation.

In conclusion, the validation of GPR17 as the primary target for a modulator such as MDL29,951 or Pranlukast requires a multi-faceted approach. By employing a battery of binding and functional assays, researchers can build a comprehensive profile of a compound's activity. The comparative data and detailed protocols provided in this guide serve as a valuable resource for the continued exploration of GPR17 as a therapeutic target for a range of pathologies, including demyelinating diseases and neuroinflammation.[15][16]

Need Custom Synthesis?

BenchChem offers custom synthesis for rare earth carbides and specific isotopic labeling.

Email: info@benchchem.com or [Request Quote Online](#).

References

- [1. GPR17: Molecular modeling and dynamics studies of the 3-D structure and purinergic ligand binding features in comparison with P2Y receptors - PMC \[pmc.ncbi.nlm.nih.gov\]](#)
- [2. guidetopharmacology.org \[guidetopharmacology.org\]](#)
- [3. Discovery of Novel and Selective GPR17 Antagonists as Pharmacological Tools for Developing New Therapeutic Strategies in Diabetes and Obesity - PMC \[pmc.ncbi.nlm.nih.gov\]](#)
- [4. researchgate.net \[researchgate.net\]](#)
- [5. researchgate.net \[researchgate.net\]](#)
- [6. pubs.acs.org \[pubs.acs.org\]](#)
- [7. Inhibition of GPR17 with pranlukast protects against TNF- \$\alpha\$ -induced loss of type II collagen in ATDC5 cells - PubMed \[pubmed.ncbi.nlm.nih.gov\]](#)
- [8. apexbt.com \[apexbt.com\]](#)
- [9. biorxiv.org \[biorxiv.org\]](#)
- [10. Innovative functional cAMP assay for studying G protein-coupled receptors: application to the pharmacological characterization of GPR17 - PMC \[pmc.ncbi.nlm.nih.gov\]](#)

- [11. Innovative functional cAMP assay for studying G protein-coupled receptors: application to the pharmacological characterization of GPR17 - PubMed \[pubmed.ncbi.nlm.nih.gov\]](#)
- [12. Characterization of G Protein-coupled Receptors by a Fluorescence-based Calcium Mobilization Assay - PMC \[pmc.ncbi.nlm.nih.gov\]](#)
- [13. Ca²⁺ Mobilization Assay - Creative Bioarray \[dda.creative-bioarray.com\]](#)
- [14. Measurement of \$\beta\$ -Arrestin Recruitment for GPCR Targets - Assay Guidance Manual - NCBI Bookshelf \[ncbi.nlm.nih.gov\]](#)
- [15. Development of the first in vivo GPR17 ligand through an iterative drug discovery pipeline: A novel disease-modifying strategy for multiple sclerosis - PMC \[pmc.ncbi.nlm.nih.gov\]](#)
- [16. GPR17 - Wikipedia \[en.wikipedia.org\]](#)
- [To cite this document: BenchChem. \[Validating GPR17 as the Primary Target of GPR17 Modulators: A Comparative Guide\]. BenchChem, \[2026\]. \[Online PDF\]. Available at: \[https://www.benchchem.com/product/b15612957/docs#validating-gpr17-as-the-primary-target-of-gpr17-modulators-a-comparative-guide\]](#)

Disclaimer & Data Validity:

The information provided in this document is for Research Use Only (RUO) and is strictly not intended for diagnostic or therapeutic procedures. While BenchChem strives to provide accurate protocols, we make no warranties, express or implied, regarding the fitness of this product for every specific experimental setup.

Technical Support: The protocols provided are for reference purposes. Unsure if this reagent suits your experiment?

Need Industrial/Bulk Grade? [Request Custom Synthesis Quote](#)

BenchChem

Our mission is to be the trusted global source of essential and advanced chemicals, empowering scientists and researchers to drive progress in science and industry.

Contact

Address: 3281 E Guasti Rd

Ontario, CA 91761, United States

Phone: (601) 213-4426

Email: info@benchchem.com

Contact our Ph.D. Support Team for a compatibility check