

Vegfr-2-IN-52: A Technical Guide to Downstream Signaling Inhibition

Author: BenchChem Technical Support Team. **Date:** April 2026

Compound of Interest

Compound Name: Vegfr-2-IN-52

Cat. No.: B15611649

[Get Quote](#)

For Researchers, Scientists, and Drug Development Professionals

Introduction

Vascular Endothelial Growth Factor Receptor 2 (VEGFR-2), a receptor tyrosine kinase, is a critical mediator of angiogenesis, the formation of new blood vessels. Its dysregulation is a hallmark of numerous pathologies, most notably cancer, where it facilitates tumor growth and metastasis. Small molecule inhibitors targeting the ATP-binding site of VEGFR-2 are therefore a cornerstone of modern anti-angiogenic therapy. This technical guide provides an in-depth overview of **Vegfr-2-IN-52**, a potent inhibitor of VEGFR-2, focusing on its impact on downstream signaling pathways, its cellular effects, and the experimental methodologies used for its characterization.

Vegfr-2-IN-52, also identified as compound 14d, is a novel thiophene-3-carboxamide derivative that has demonstrated significant potential as an anti-angiogenic agent.[1] This document will detail its mechanism of action, present available quantitative data, and provide standardized protocols for the key experiments that elucidate its biological activity.

Core Downstream Signaling Pathways of VEGFR-2

The binding of Vascular Endothelial Growth Factor (VEGF) to VEGFR-2 induces receptor dimerization and autophosphorylation of specific tyrosine residues in its intracellular domain. This initiates a cascade of downstream signaling events that regulate endothelial cell proliferation, survival, migration, and permeability. The primary signaling axes affected by **Vegfr-2-IN-52** are outlined below.

The PLC γ -PKC-MAPK Pathway: Proliferation

Upon VEGFR-2 activation, Phospholipase C gamma (PLC γ) is recruited and activated, leading to the hydrolysis of phosphatidylinositol 4,5-bisphosphate (PIP₂) into inositol trisphosphate (IP₃) and diacylglycerol (DAG). DAG, in turn, activates Protein Kinase C (PKC), which subsequently triggers the Raf-MEK-ERK (MAPK) cascade. This pathway is a central driver of endothelial cell proliferation. **Vegfr-2-IN-52**, by inhibiting the initial phosphorylation of VEGFR-2, effectively abrogates this entire signaling chain.^[2]

The PI3K/Akt Pathway: Survival

The Phosphoinositide 3-kinase (PI3K)/Akt pathway is another critical downstream effector of VEGFR-2, playing a pivotal role in endothelial cell survival and migration. Activated VEGFR-2 recruits and activates PI3K, leading to the production of phosphatidylinositol (3,4,5)-trisphosphate (PIP₃). PIP₃ serves as a docking site for Akt (also known as Protein Kinase B), which upon activation, phosphorylates numerous downstream targets that promote cell survival and inhibit apoptosis.

The Src-FAK Pathway: Migration

Src family kinases are also activated upon VEGFR-2 autophosphorylation. This leads to the activation of Focal Adhesion Kinase (FAK), a key regulator of cell adhesion and migration. This pathway is essential for the dynamic changes in the cytoskeleton required for endothelial cell motility during angiogenesis.

Mechanism of Action of Vegfr-2-IN-52

Vegfr-2-IN-52 functions as a potent, ATP-competitive inhibitor of the VEGFR-2 kinase domain. Its primary mechanism involves the direct suppression of the receptor's autophosphorylation, thereby preventing the initiation of all downstream signaling cascades.

Quantitative Data

The inhibitory potency and cellular effects of **Vegfr-2-IN-52** have been quantified in several key assays. The available data is summarized in the tables below.

Target	IC50 (nM)	Assay Type
VEGFR-2	191.1	Kinase Assay

Table 1: In Vitro Inhibitory Potency of Vegfr-2-IN-52.[\[2\]](#)[\[3\]](#)

Cellular Effect	Observation	Affected Pathways
Cytotoxicity	Induces cancer cell death	Apoptosis Induction
Apoptosis	Increased rates of programmed cell death	Caspase activation
Cell Cycle Arrest	Accumulation of cells in the G0/G1 phase	Inhibition of proliferative signaling
ROS Production	Increased levels of Reactive Oxygen Species	Cellular Stress Pathways
Protein Phosphorylation	Decreased levels of p-VEGFR-2, p-MEK1, and p-ERK1/2	MAPK/ERK Pathway
MMP9 Expression	Decreased	Invasion and Metastasis Pathways

Table 2: Cellular Effects of Vegfr-2-IN-52.[\[2\]](#)[\[4\]](#)

Visualizing the Impact of Vegfr-2-IN-52

The following diagrams, generated using the DOT language, illustrate the VEGFR-2 signaling pathway and the point of intervention for **Vegfr-2-IN-52**, as well as a typical experimental workflow for its characterization.

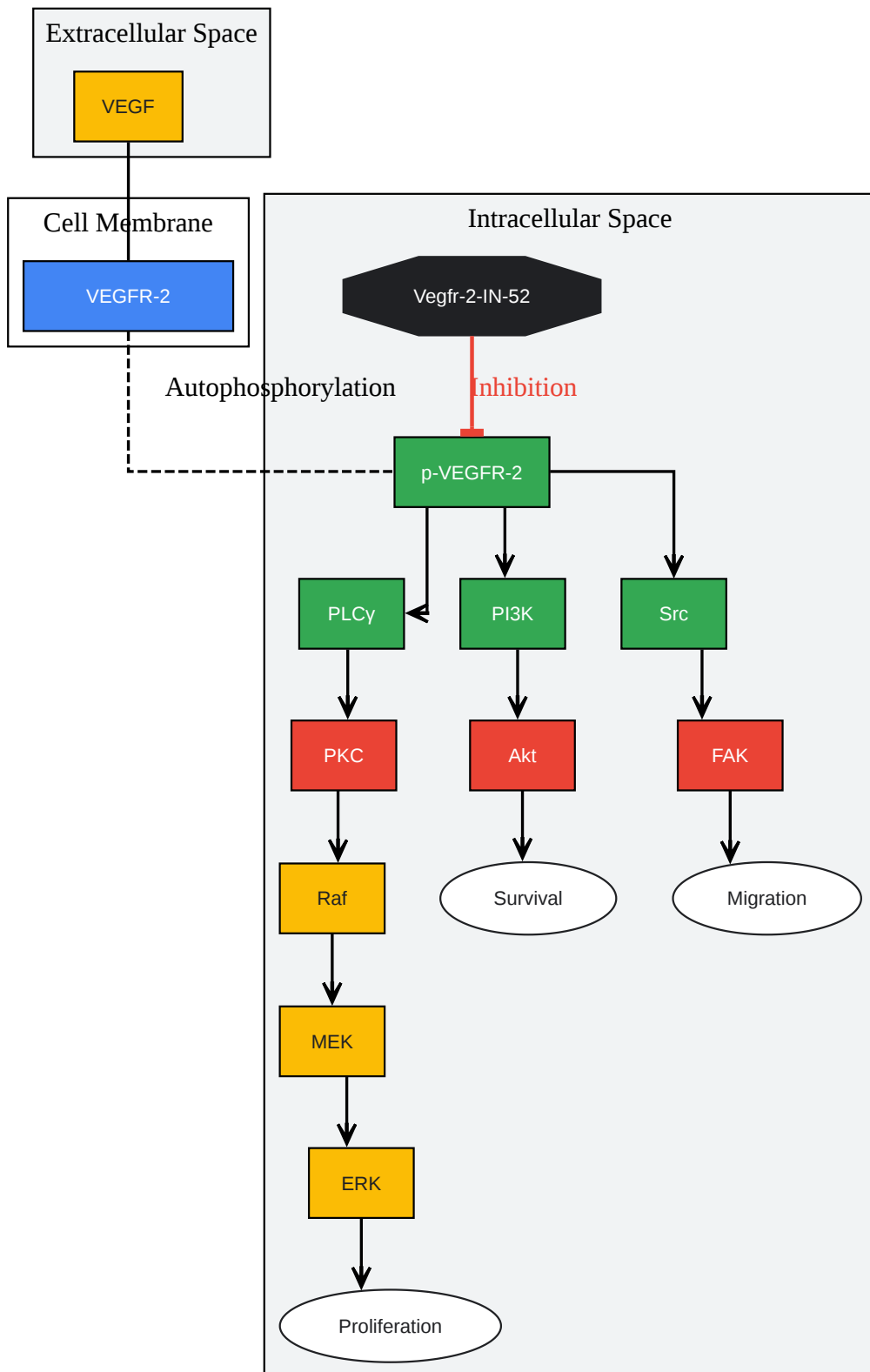

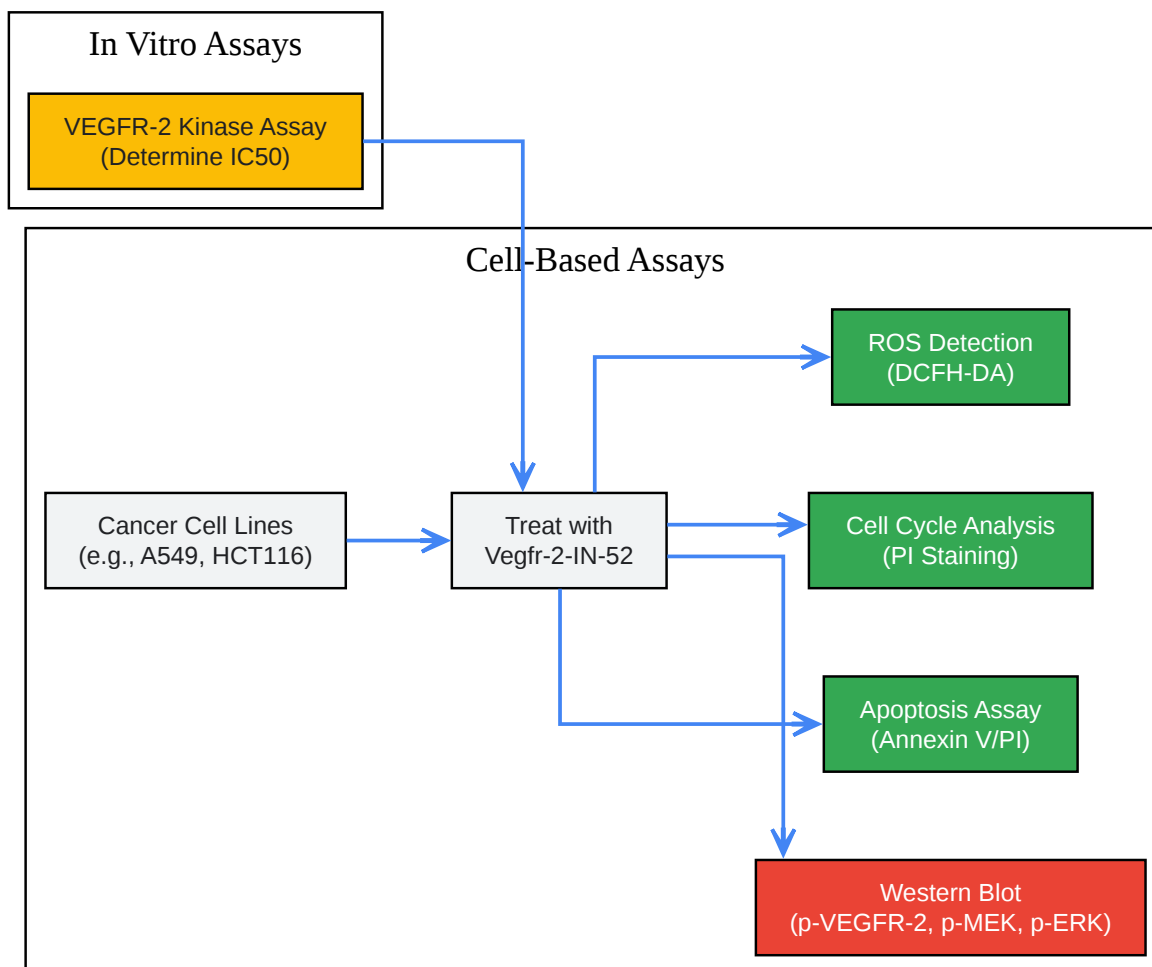

[Click to download full resolution via product page](#)

Need Custom Synthesis?

BenchChem offers custom synthesis for rare earth carbides and specific isotopic labeling.
Email: info@benchchem.com or [Request Quote Online](#).

References

- 1. Discovery of novel thiophene-3-carboxamide derivatives as potential VEGFR-2 inhibitors with anti-angiogenic properties - PubMed [pubmed.ncbi.nlm.nih.gov]
- 2. Flow cytometry with PI staining | Abcam [abcam.com]

- [3. BestProtocols: Annexin V Staining Protocol for Flow Cytometry | Thermo Fisher Scientific - US \[thermofisher.com\]](#)
- [4. kumc.edu \[kumc.edu\]](#)
- To cite this document: BenchChem. [Vegfr-2-IN-52: A Technical Guide to Downstream Signaling Inhibition]. BenchChem, [2026]. [Online PDF]. Available at: [\[https://www.benchchem.com/product/b15611649/docs#vegfr-2-in-52-a-technical-guide-to-downstream-signaling-inhibition\]](https://www.benchchem.com/product/b15611649/docs#vegfr-2-in-52-a-technical-guide-to-downstream-signaling-inhibition)

Disclaimer & Data Validity:

The information provided in this document is for Research Use Only (RUO) and is strictly not intended for diagnostic or therapeutic procedures. While BenchChem strives to provide accurate protocols, we make no warranties, express or implied, regarding the fitness of this product for every specific experimental setup.

Technical Support: The protocols provided are for reference purposes. Unsure if this reagent suits your experiment?

Need Industrial/Bulk Grade? [Request Custom Synthesis Quote](#)

BenchChem

Our mission is to be the trusted global source of essential and advanced chemicals, empowering scientists and researchers to drive progress in science and industry.

Contact

Address: 3281 E Guasti Rd
Ontario, CA 91761, United States
Phone: (601) 213-4426
Email: info@benchchem.com

[Contact our Ph.D. Support Team for a compatibility check](#)

