

# Experimental Design for Sunitinib Maleate Combination Therapy Studies: Application Notes and Protocols

**Author:** BenchChem Technical Support Team. **Date:** April 2026

## Compound of Interest

Compound Name: *Sunitinib Maleate*

CAS No.: *1701408-75-4*

Cat. No.: *B15611909*

[Get Quote](#)

For Researchers, Scientists, and Drug Development Professionals

These application notes provide a comprehensive guide for designing and conducting preclinical studies to evaluate Sunitinib Maleate in combination with other therapeutic agents. The protocols outlined below are intended to serve as a foundation for researchers to develop more specific experimental plans tailored to their research questions and model systems.

## Introduction to Sunitinib Maleate

Sunitinib Maleate is an oral, multi-targeted receptor tyrosine kinase (RTK) inhibitor.<sup>[1][2]</sup> Its primary mechanism of action involves the inhibition of several RTKs implicated in tumor growth, angiogenesis, and metastatic progression.<sup>[1][3]</sup> Key targets include:

- Vascular Endothelial Growth Factor Receptors (VEGFRs): VEGFR1, VEGFR2, and VEGFR3<sup>[1][3]</sup>
- Platelet-Derived Growth Factor Receptors (PDGFRs): PDGFR $\alpha$  and PDGFR $\beta$ <sup>[1][3]</sup>

- Stem Cell Factor Receptor (c-KIT)[1]
- Fms-like Tyrosine Kinase-3 (FLT3)[1][3]
- Colony-Stimulating Factor Receptor Type 1 (CSF-1R)[3]
- Glial Cell Line-Derived Neurotrophic Factor Receptor (RET)[1][3]

By simultaneously blocking these signaling pathways, Sunitinib exerts both anti-angiogenic and direct anti-tumor effects.[1] It is approved for the treatment of renal cell carcinoma (RCC) and imatinib-resistant gastrointestinal stromal tumors (GIST).[2] The rationale for combination therapies with Sunitinib often stems from the need to overcome resistance, enhance efficacy, or target complementary oncogenic pathways.[4]

## Key Signaling Pathways Targeted by Sunitinib

Understanding the signaling pathways affected by Sunitinib is crucial for designing rational combination therapies. Below are simplified diagrams of the major pathways inhibited by Sunitinib.

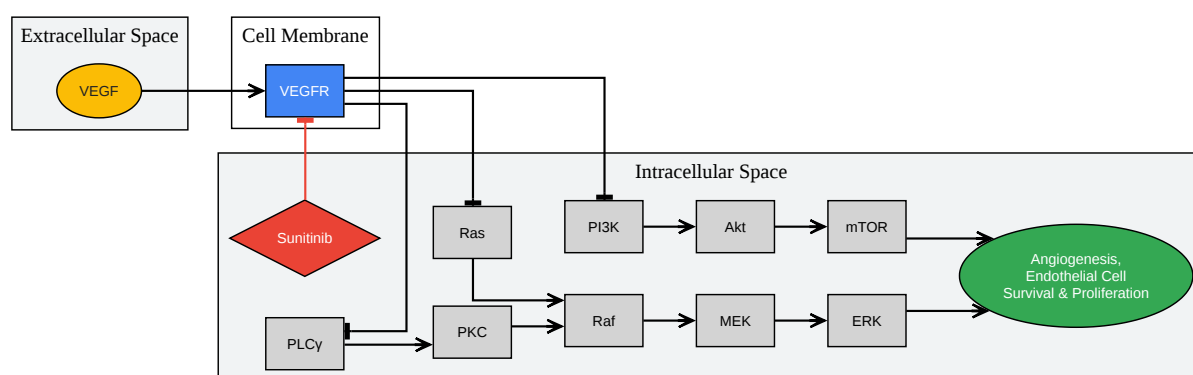

[Click to download full resolution via product page](#)

VEGFR Signaling Pathway Inhibition by Sunitinib.

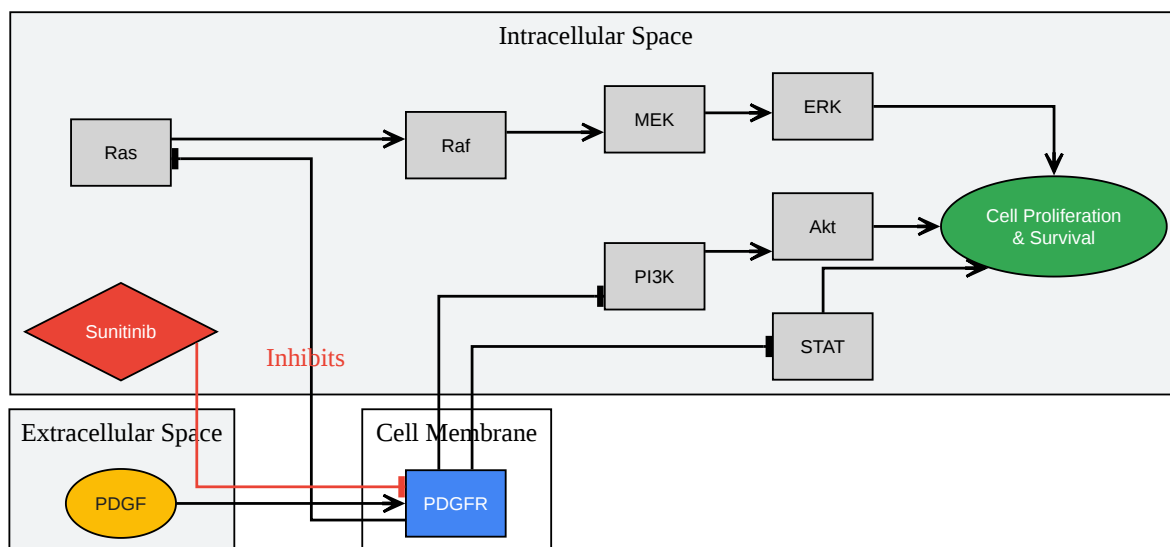

[Click to download full resolution via product page](#)

PDGFR Signaling Pathway Inhibition by Sunitinib.

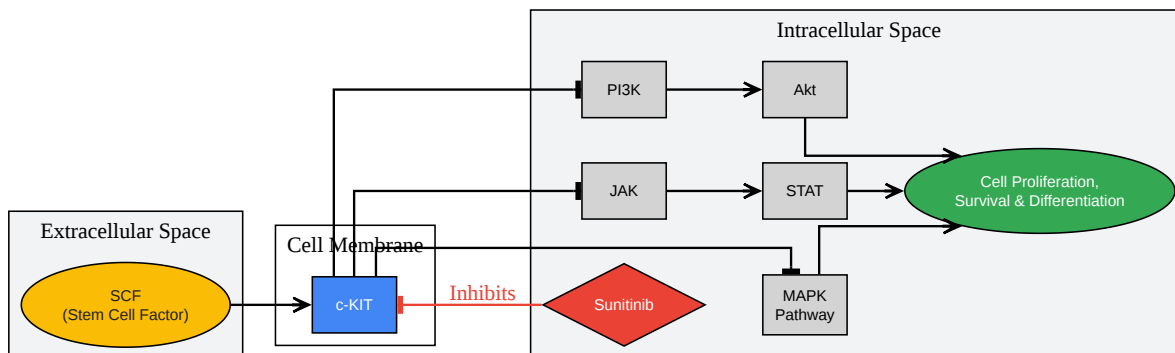

[Click to download full resolution via product page](#)

c-KIT Signaling Pathway Inhibition by Sunitinib.

## Experimental Design and Workflow

A systematic approach is essential for evaluating Sunitinib combination therapies. The following workflow outlines the key stages of a preclinical study.

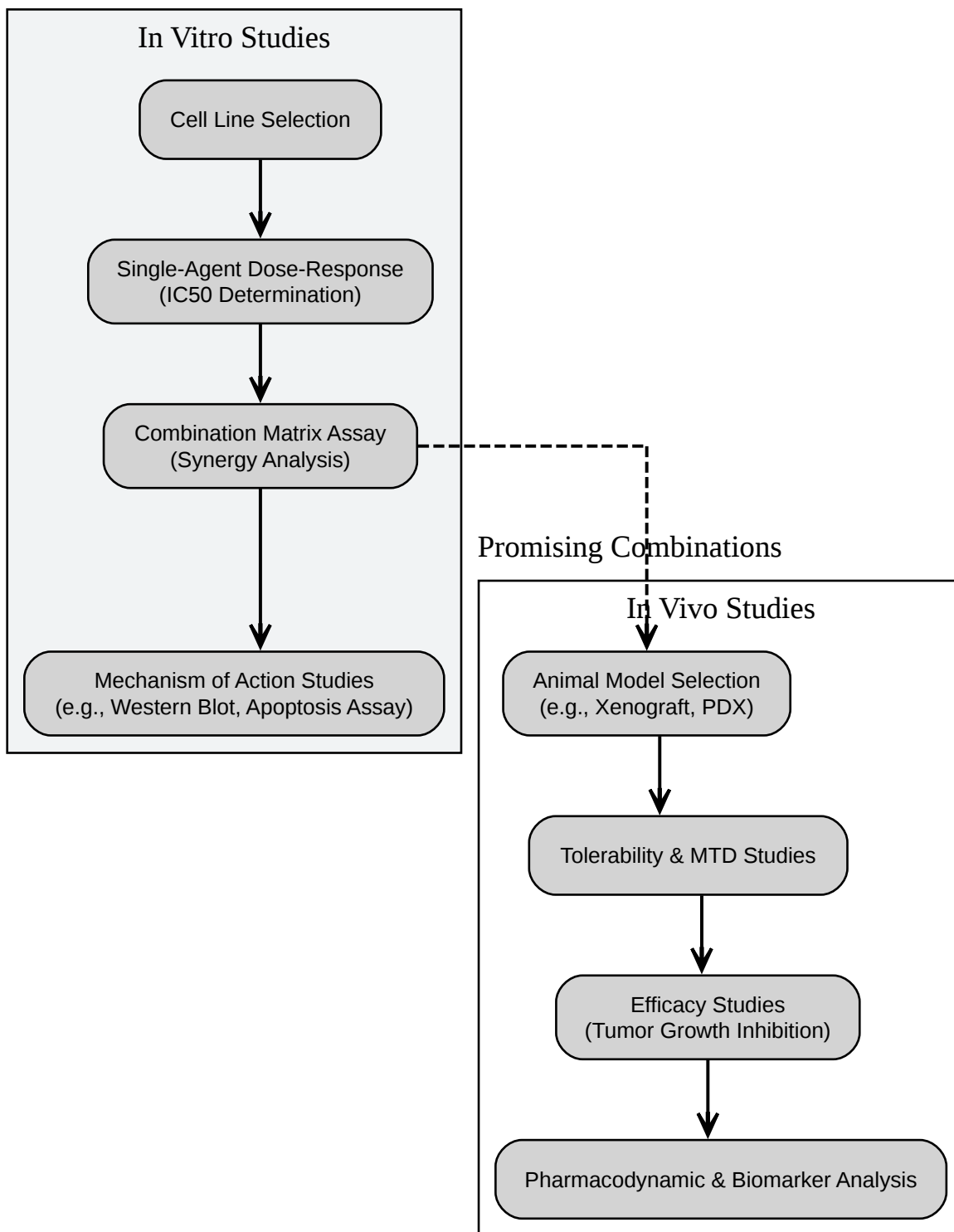

[Click to download full resolution via product page](#)

General Experimental Workflow for Combination Studies.

# In Vitro Experimental Protocols

## Cell Viability Assays (MTT/MTS)

Objective: To determine the cytotoxic or cytostatic effects of Sunitinib alone and in combination with other drugs and to assess for synergistic, additive, or antagonistic interactions.

Protocol:

- Cell Seeding:
  - Seed cells in a 96-well plate at a predetermined optimal density (e.g., 5,000-10,000 cells/well) in 100  $\mu$ L of complete culture medium.
  - Incubate for 24 hours at 37°C and 5% CO<sub>2</sub> to allow for cell attachment.
- Drug Treatment:
  - Prepare serial dilutions of Sunitinib and the combination drug(s) in culture medium.
  - For single-agent dose-response, treat cells with a range of concentrations of each drug individually.
  - For combination studies, treat cells with a matrix of concentrations of both drugs.
  - Include vehicle-treated controls.
  - The final volume in each well should be 200  $\mu$ L.
- Incubation:
  - Incubate the plates for a predetermined duration (e.g., 48 or 72 hours).
- MTT/MTS Assay:
  - For MTT: Add 20  $\mu$ L of 5 mg/mL MTT solution to each well and incubate for 2-4 hours. Then, add 150  $\mu$ L of a solubilizing agent (e.g., DMSO) and incubate for 15 minutes with gentle shaking.

- For MTS: Add 20  $\mu$ L of MTS reagent to each well and incubate for 1-4 hours.
- Read the absorbance at the appropriate wavelength (e.g., 570 nm for MTT, 490 nm for MTS) using a microplate reader.

#### Data Analysis:

- Calculate the percentage of cell viability relative to the vehicle control.
- Determine the IC50 value for each single agent.
- For combination studies, use software such as CompuSyn or SynergyFinder to calculate the Combination Index (CI), where  $CI < 1$  indicates synergy,  $CI = 1$  indicates an additive effect, and  $CI > 1$  indicates antagonism.

## Western Blot Analysis

Objective: To investigate the molecular mechanisms of action by assessing the phosphorylation status and expression levels of key proteins in the signaling pathways targeted by Sunitinib and its combination partners.

#### Protocol:

- Cell Lysis:
  - Treat cells with Sunitinib, the combination drug(s), or vehicle for the desired time.
  - Wash cells with ice-cold PBS and lyse them in RIPA buffer containing protease and phosphatase inhibitors.
  - Quantify protein concentration using a BCA assay.
- SDS-PAGE and Transfer:
  - Separate equal amounts of protein (e.g., 20-30  $\mu$ g) on an SDS-polyacrylamide gel.
  - Transfer the separated proteins to a PVDF or nitrocellulose membrane.
- Immunoblotting:

- Block the membrane with 5% non-fat milk or BSA in TBST for 1 hour at room temperature.
- Incubate the membrane with primary antibodies against target proteins (e.g., phospho-VEGFR2, total VEGFR2, phospho-Akt, total Akt, cleaved caspase-3) overnight at 4°C.
- Wash the membrane and incubate with HRP-conjugated secondary antibodies for 1 hour at room temperature.
- Detection:
  - Detect the protein bands using an enhanced chemiluminescence (ECL) substrate and an imaging system.
  - Use a loading control (e.g.,  $\beta$ -actin or GAPDH) to ensure equal protein loading.

## In Vivo Experimental Protocols

### Xenograft Tumor Model

Objective: To evaluate the anti-tumor efficacy of Sunitinib in combination with other agents in a living organism.

Protocol:

- Cell Implantation:
  - Subcutaneously inject a suspension of cancer cells (e.g.,  $1-5 \times 10^6$  cells) in a suitable medium (e.g., Matrigel) into the flank of immunocompromised mice (e.g., nude or SCID mice).
- Tumor Growth and Randomization:
  - Monitor tumor growth using calipers.
  - When tumors reach a palpable size (e.g., 100-200 mm<sup>3</sup>), randomize the mice into treatment groups (e.g., n=8-10 per group):
    - Group 1: Vehicle control

- Group 2: Sunitinib alone
- Group 3: Combination drug alone
- Group 4: Sunitinib + combination drug
- Drug Administration:
  - Administer Sunitinib (e.g., by oral gavage) and the combination drug according to a predetermined dose and schedule. The timing of administration (concurrent vs. sequential) can be a key variable to investigate.[\[5\]](#)
- Monitoring and Endpoints:
  - Measure tumor volume and body weight regularly (e.g., 2-3 times per week).
  - The primary endpoint is typically tumor growth inhibition.
  - At the end of the study, tumors can be excised for pharmacodynamic and biomarker analysis (e.g., immunohistochemistry, western blot).

Data Presentation:

Quantitative data from in vitro and in vivo studies should be summarized in clear and concise tables to facilitate comparison between different treatment groups.

Table 1: In Vitro Cell Viability (IC<sub>50</sub> Values)

Cell Line	Sunitinib IC <sub>50</sub> (μM)	Combination Drug X IC <sub>50</sub> (μM)
RCC-1	5.2	10.8
GIST-T1	2.8	8.5
NSCLC-A549	12.1	25.3

Table 2: In Vivo Tumor Growth Inhibition

Treatment Group	Mean Tumor Volume (mm <sup>3</sup> ) at Day 21	% Tumor Growth Inhibition (TGI)	p-value (vs. Vehicle)
Vehicle	1500 ± 250	-	-
Sunitinib (40 mg/kg)	800 ± 150	46.7%	<0.05
Drug X (10 mg/kg)	1000 ± 200	33.3%	<0.05
Sunitinib + Drug X	300 ± 100	80.0%	<0.001

## Conclusion

The successful design and execution of Sunitinib combination therapy studies require a multi-faceted approach, integrating in vitro and in vivo models. The protocols and workflows presented here provide a framework for the systematic evaluation of novel therapeutic combinations, with the ultimate goal of identifying synergistic interactions that can be translated into improved clinical outcomes for cancer patients. Careful consideration of experimental design, appropriate controls, and robust data analysis are paramount to generating reliable and reproducible results.

### Need Custom Synthesis?

BenchChem offers custom synthesis for rare earth carbides and specific isotopic labeling.

Email: [info@benchchem.com](mailto:info@benchchem.com) or [Request Quote Online](#).

## References

- 1. [researchgate.net \[researchgate.net\]](#)
- 2. [researchgate.net \[researchgate.net\]](#)
- 3. [ClinPGx \[clinpgx.org\]](#)
- 4. [texaschildrens.org \[texaschildrens.org\]](#)
- 5. [Combination of Sunitinib with anti-tumor vaccination inhibits T cell priming and requires careful scheduling to achieve productive immunotherapy - PMC \[pmc.ncbi.nlm.nih.gov\]](#)

- To cite this document: BenchChem. [Experimental Design for Sunitinib Maleate Combination Therapy Studies: Application Notes and Protocols]. BenchChem, [2026]. [Online PDF]. Available at: [<https://www.benchchem.com/product/b15611909/docs#experimental-design-for-sunitinib-maleate-combination-therapy-studies-application-notes-and-protocols>]

---

### Disclaimer & Data Validity:

The information provided in this document is for Research Use Only (RUO) and is strictly not intended for diagnostic or therapeutic procedures. While BenchChem strives to provide accurate protocols, we make no warranties, express or implied, regarding the fitness of this product for every specific experimental setup.

**Technical Support:** The protocols provided are for reference purposes. Unsure if this reagent suits your experiment?

**Need Industrial/Bulk Grade?** [Request Custom Synthesis Quote](#)

## BenchChem

Our mission is to be the trusted global source of essential and advanced chemicals, empowering scientists and researchers to drive progress in science and industry.

### Contact

Address: 3281 E Guasti Rd  
Ontario, CA 91761, United States  
Phone: (601) 213-4426  
Email: [info@benchchem.com](mailto:info@benchchem.com)

[Contact our Ph.D. Support Team for a compatibility check](#)