

# A Comparative Guide to Fibroblast Activation Protein (FAP) Inhibitors for Researchers

**Author:** BenchChem Technical Support Team. **Date:** April 2026

## Compound of Interest

Compound Name: *Fluorogen binding modulator-1*

Cat. No.: *B15611155*

[Get Quote](#)

An important clarification on "**Fluorogen binding modulator-1**": Initial analysis of the topic revealed a potential ambiguity in the term "FAP." Commercially available information describes "**Fluorogen binding modulator-1**" as a modulator of Fluorogen Activating Protein (FAP), a type of biosensor technology, with reported EC50 values for G protein-coupled receptors AM2.2-β2AR and AM2.2-GPR32.[1][2] In contrast, the vast majority of cancer-related research on "FAP inhibitors" pertains to Fibroblast Activation Protein (FAP), a cell-surface serine protease and a key player in the tumor microenvironment.

Currently, there is no direct scientific literature demonstrating that "**Fluorogen binding modulator-1**" acts as an inhibitor of Fibroblast Activation Protein. Therefore, a direct comparison of its inhibitory activity with established Fibroblast Activation Protein Inhibitors (FAPIs) is not feasible. This guide will focus on providing a detailed comparison of well-characterized inhibitors of Fibroblast Activation Protein.

## Introduction to Fibroblast Activation Protein (FAP)

Fibroblast Activation Protein (FAP) is a type II transmembrane serine protease that is highly expressed on cancer-associated fibroblasts (CAFs) in the stroma of most epithelial tumors, while its expression in normal adult tissues is low. This differential expression makes FAP an

attractive target for cancer diagnosis and therapy. FAP plays a role in tumor progression through various mechanisms, including remodeling of the extracellular matrix and modulation of signaling pathways that promote tumor growth and invasion.

## Comparative Analysis of FAP Inhibitors

A range of FAP inhibitors have been developed, primarily for applications in cancer imaging (theranostics) and as potential therapeutic agents. Below is a comparative table summarizing the inhibitory potency and selectivity of some prominent FAP inhibitors.

Inhibitor	FAP IC50 (nM)	PREP IC50 (μM)	Selectivity (PREP/FAP)	Notes
UAMC-1110	3.2[3]	1.8[3]	~563	Highly potent and selective.
Talabostat (PT-100)	560[4][5]	-	-	Also a potent inhibitor of DPP-IV (IC50 < 4 nM). [4][5]
FAPI-04	6.55	-	-	Widely used as a PET imaging agent.
FAPI-46	-	-	-	A quinoline-based FAP-targeted radiotracer.[6][7]
DOTA.SA.FAPi	0.9[8]	5.4[8]	~6000	High affinity and selectivity.
QI-18	0.50	-	-	6.5-fold more potent than UAMC-1110.[8]
FAP-IN-1	3.3[8]	-	-	-
FAP-IN-5	1.7[8]	-	-	-

IC50 values can vary depending on the assay conditions. Data presented here is for comparative purposes.

## Signaling Pathways Involving FAP

FAP's role in cancer progression is mediated through its influence on several key signaling pathways within cancer-associated fibroblasts and surrounding tumor cells. These pathways are critical for cell proliferation, survival, and migration.

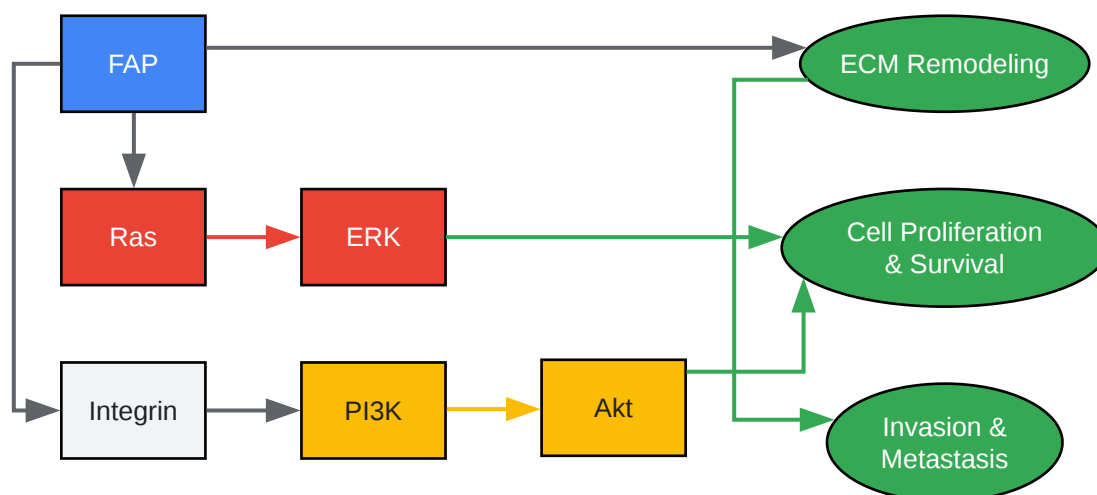

[Click to download full resolution via product page](#)

Caption: Simplified FAP signaling pathways in cancer.

## Experimental Protocols

### FAP Enzyme Inhibition Assay (IC50 Determination)

This protocol describes a common method to determine the half-maximal inhibitory concentration (IC50) of a compound against FAP using a fluorogenic substrate.

Workflow Diagram:

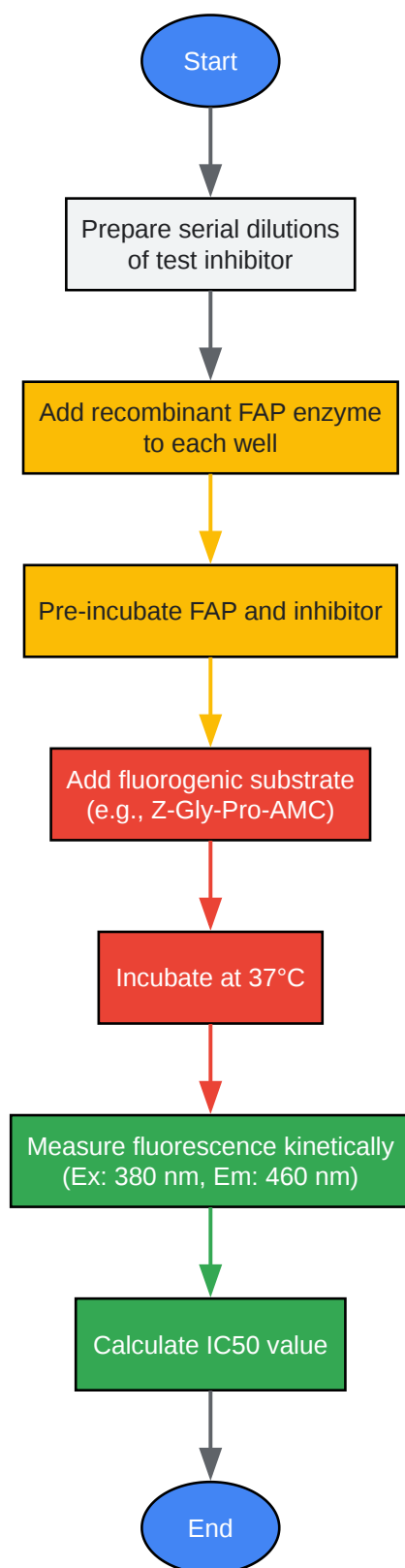

[Click to download full resolution via product page](#)

### Need Custom Synthesis?

BenchChem offers custom synthesis for rare earth carbides and specific isotopic labeling.

Email: [info@benchchem.com](mailto:info@benchchem.com) or [Request Quote Online](#).

## References

- [1. jnm.snmjournals.org](http://jnm.snmjournals.org) [jnm.snmjournals.org]
- [2. pubs.acs.org](http://pubs.acs.org) [pubs.acs.org]
- [3. academic.oup.com](http://academic.oup.com) [academic.oup.com]
- [4. academic.oup.com](http://academic.oup.com) [academic.oup.com]
- [5. The role of fibroblast activation protein in health and malignancy - PMC](#) [pmc.ncbi.nlm.nih.gov]
- [6. Pro-tumorigenic roles of fibroblast activation protein in cancer: back to the basics - PMC](#) [pmc.ncbi.nlm.nih.gov]
- [7. bpsbioscience.com](http://bpsbioscience.com) [bpsbioscience.com]
- [8. researchgate.net](http://researchgate.net) [researchgate.net]
- To cite this document: BenchChem. [A Comparative Guide to Fibroblast Activation Protein (FAP) Inhibitors for Researchers]. BenchChem, [2026]. [Online PDF]. Available at: [https://www.benchchem.com/product/b15611155/docs#a-comparative-guide-to-fibroblast-activation-protein-fap-inhibitors-for-researchers]

---

### Disclaimer & Data Validity:

The information provided in this document is for Research Use Only (RUO) and is strictly not intended for diagnostic or therapeutic procedures. While BenchChem strives to provide accurate protocols, we make no warranties, express or implied, regarding the fitness of this product for every specific experimental setup.

**Technical Support:** The protocols provided are for reference purposes. Unsure if this reagent suits your experiment?

**Need Industrial/Bulk Grade?** [Request Custom Synthesis Quote](#)

# BenchChem

Our mission is to be the trusted global source of essential and advanced chemicals, empowering scientists and researchers to drive progress in science and industry.

## Contact

Address: 3281 E Guasti Rd

Ontario, CA 91761, United States

Phone: (601) 213-4426

Email: [info@benchchem.com](mailto:info@benchchem.com)

[Contact our Ph.D. Support Team for a compatibility check](#)