

Validating the Selectivity of PROTAC HER2 Degradar-1: A Comparative Guide

Author: BenchChem Technical Support Team. **Date:** April 2026

Compound of Interest

Compound Name: PROTAC HER2 degrader-1

Cat. No.: B15610871

Get Quote

For Researchers, Scientists, and Drug Development Professionals

The advent of Proteolysis Targeting Chimeras (PROTACs) has introduced a novel paradigm in targeted therapy, shifting the focus from protein inhibition to induced protein degradation.

PROTAC HER2 degrader-1, also identified as CH7C4, has emerged as a potent and selective molecule for targeting HER2-overexpressing cancers.^{[1][2][3]} This guide provides a comprehensive comparison of **PROTAC HER2 degrader-1** with other HER2-targeting agents and details the experimental methodologies for validating its selectivity.

Performance Comparison

PROTAC HER2 degrader-1 (CH7C4) demonstrates high efficacy in degrading HER2 and inhibiting the proliferation of HER2-positive cancer cells.^{[1][2][3]} A summary of its performance compared to alternative HER2-targeted therapies is presented below.

Therapeutic Modality	Agent	Mechanism of Action	Target	Efficacy Metrics	Selectivity
PROTAC Degraders	HER2 degrader-1 (CH7C4)	Induces ubiquitination and proteasomal degradation of HER2.	HER2 Protein	DC50: 69 nM (BT-474 cells) Dmax: 96% (BT-474 cells) IC50: 0.047 nM (BT-474 cells)	High selectivity for HER2 over other kinases.[1][2][3]
Tyrosine Kinase Inhibitor (TKI)	Tucatinib	Reversibly inhibits the intracellular kinase domain of HER2.	HER2 Kinase Activity	IC50: 8 nM (HER2 kinase assay)	Selective for HER2 over EGFR.
Antibody-Drug Conjugate (ADC)	Trastuzumab deruxtecan (T-DXd)	An antibody that targets HER2 on the cell surface, delivering a cytotoxic payload.	Extracellular domain of HER2	Not directly comparable with DC50/IC50 of small molecules. Efficacy is measured by clinical outcomes like progression-free survival.	High selectivity for HER2-expressing cells due to the antibody component. [4]

Experimental Validation of Selectivity

The selectivity of a PROTAC is paramount to its therapeutic potential, minimizing off-target effects and associated toxicities. The following are key experiments to validate the selectivity of **PROTAC HER2 degrader-1**.

Western Blotting for On-Target Degradation and Off-Target Effects

Western blotting is a fundamental technique to visualize and quantify the degradation of the target protein and assess the impact on other related proteins.

Experimental Protocol:

- Cell Culture and Treatment:
 - Seed HER2-positive human breast cancer cells (e.g., BT-474) and a HER2-negative cell line (e.g., A431 for EGFR) in 6-well plates and culture until they reach 70-80% confluency.
 - Treat the cells with varying concentrations of **PROTAC HER2 degrader-1** (e.g., 0.1, 1, 10, 100, 1000 nM) and a vehicle control (DMSO) for 24 hours.
- Cell Lysis:
 - Wash the cells with ice-cold phosphate-buffered saline (PBS).
 - Lyse the cells in RIPA buffer supplemented with protease and phosphatase inhibitors.
 - Centrifuge the lysates at 14,000 rpm for 15 minutes at 4°C to pellet cell debris.
- Protein Quantification:
 - Determine the protein concentration of the supernatant using a BCA protein assay.
- SDS-PAGE and Protein Transfer:
 - Normalize protein concentrations for all samples and prepare them with Laemmli sample buffer.
 - Separate the proteins on an 8-10% SDS-polyacrylamide gel.
 - Transfer the separated proteins to a polyvinylidene difluoride (PVDF) membrane.
- Immunoblotting:

- Block the membrane with 5% non-fat milk in Tris-buffered saline with 0.1% Tween 20 (TBST) for 1 hour at room temperature.
- Incubate the membrane with primary antibodies against HER2, EGFR, and a loading control (e.g., GAPDH or β -actin) overnight at 4°C.
- Wash the membrane three times with TBST.
- Incubate with a horseradish peroxidase (HRP)-conjugated secondary antibody for 1 hour at room temperature.
- Wash the membrane again three times with TBST.
- Detection and Analysis:
 - Visualize the protein bands using an enhanced chemiluminescence (ECL) detection system.
 - Quantify the band intensities using densitometry software to determine the extent of protein degradation relative to the vehicle control.

Mass Spectrometry-Based Proteomics for Global Off-Target Analysis

This unbiased approach provides a global view of the proteome to identify any unintended protein degradation, thus offering a comprehensive selectivity profile.

Experimental Protocol:

- Sample Preparation:
 - Treat HER2-positive cells (e.g., BT-474) with **PROTAC HER2 degrader-1** (at a concentration known to induce maximal degradation, e.g., 200 nM) and a vehicle control for 24 hours.
 - Harvest and lyse the cells as described in the Western blot protocol.
- Protein Digestion and Peptide Labeling:

- Denature, reduce, and alkylate the proteins from the cell lysates.
- Digest the proteins into peptides using trypsin.
- Label the peptides with isobaric tags (e.g., TMT or iTRAQ) for multiplexed quantitative analysis.
- Liquid Chromatography-Mass Spectrometry (LC-MS/MS):
 - Separate the labeled peptides using high-performance liquid chromatography (HPLC).
 - Analyze the peptides using a high-resolution mass spectrometer.
- Data Analysis:
 - Process the raw mass spectrometry data to identify and quantify proteins.
 - Compare the protein abundance between the PROTAC-treated and vehicle-treated samples.
 - Identify proteins that are significantly downregulated, indicating potential off-target degradation.

Visualizing the Mechanism and Workflow

To better understand the underlying processes, the following diagrams illustrate the HER2 signaling pathway, the mechanism of **PROTAC HER2 degrader-1**, and the experimental workflow for its validation.

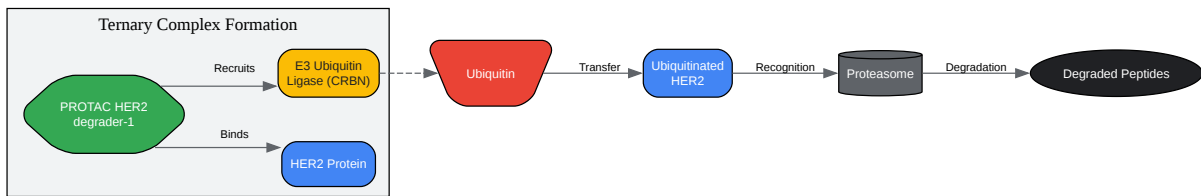
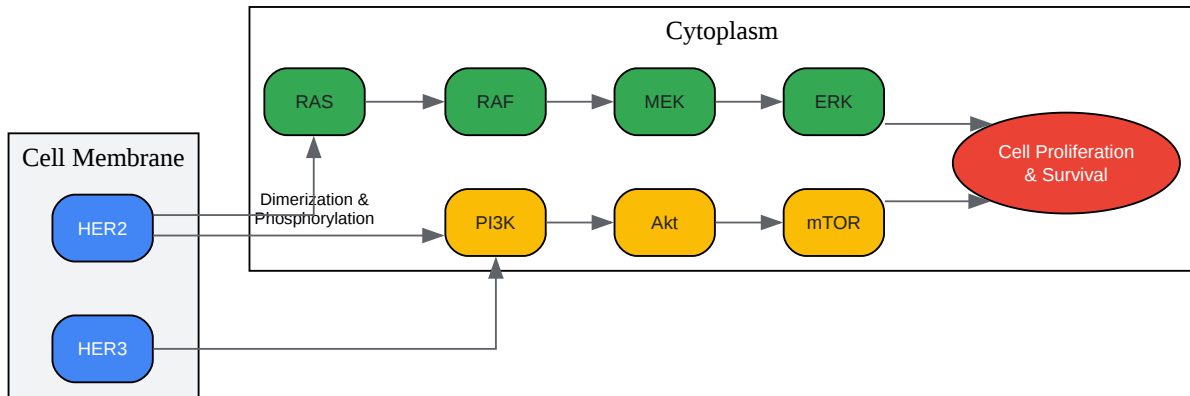

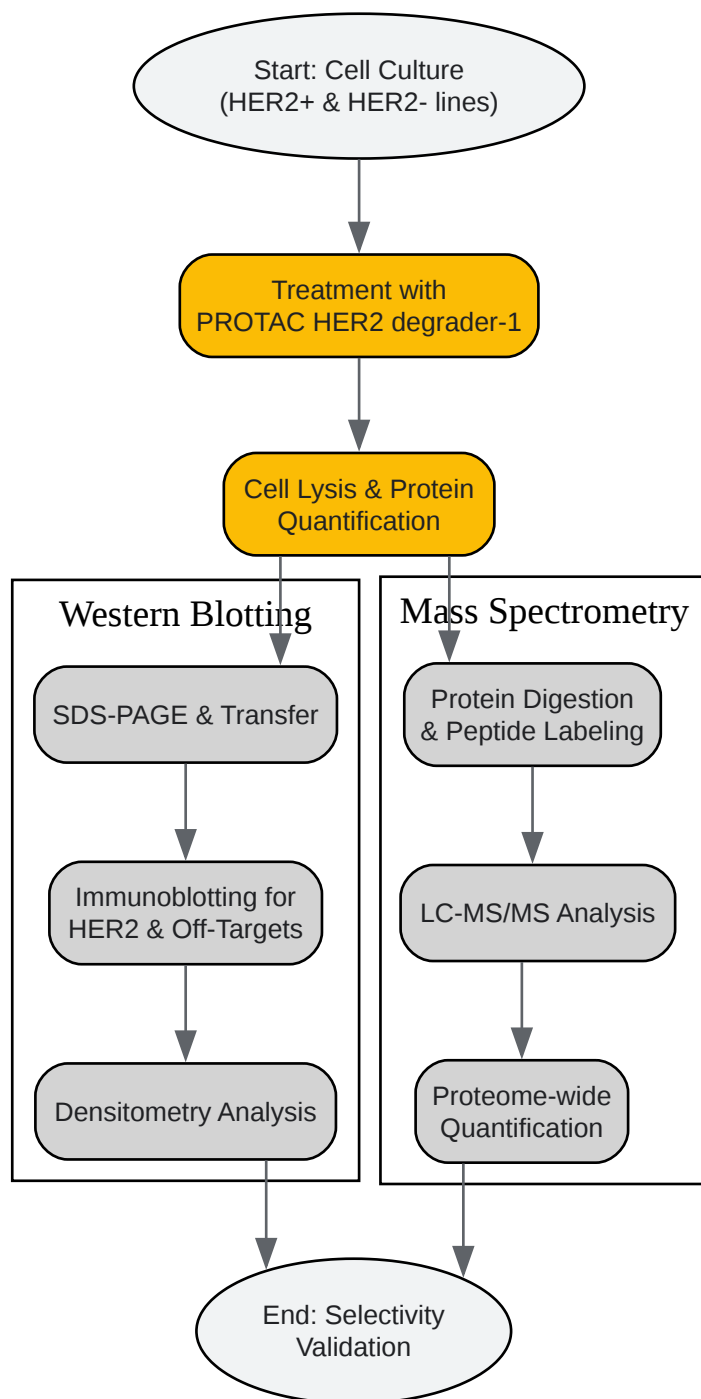

[Click to download full resolution via product page](#)

Need Custom Synthesis?

BenchChem offers custom synthesis for rare earth carbides and specific isotopic labeling.

Email: info@benchchem.com or [Request Quote Online](#).

References

- [1. Discovery of potent and selective HER2 PROTAC degrader based Tucatinib with improved efficacy against HER2 positive cancers - PubMed \[pubmed.ncbi.nlm.nih.gov\]](#)
- [2. researchgate.net \[researchgate.net\]](#)
- [3. medchemexpress.com \[medchemexpress.com\]](#)
- [4. Comparative Efficacy of Tyrosine Kinase Inhibitors and Antibody–Drug Conjugates in HER2-Positive Metastatic Breast Cancer Patients with Brain Metastases: A Systematic Review and Network Meta-Analysis - PMC \[pmc.ncbi.nlm.nih.gov\]](#)
- To cite this document: BenchChem. [Validating the Selectivity of PROTAC HER2 Degradation-1: A Comparative Guide]. BenchChem, [2026]. [Online PDF]. Available at: [\[https://www.benchchem.com/product/b15610871/docs#validating-the-selectivity-of-protac-her2-degrader-1-a-comparative-guide\]](https://www.benchchem.com/product/b15610871/docs#validating-the-selectivity-of-protac-her2-degrader-1-a-comparative-guide)

Disclaimer & Data Validity:

The information provided in this document is for Research Use Only (RUO) and is strictly not intended for diagnostic or therapeutic procedures. While BenchChem strives to provide accurate protocols, we make no warranties, express or implied, regarding the fitness of this product for every specific experimental setup.

Technical Support: The protocols provided are for reference purposes. Unsure if this reagent suits your experiment?

Need Industrial/Bulk Grade? [Request Custom Synthesis Quote](#)

BenchChem

Our mission is to be the trusted global source of essential and advanced chemicals, empowering scientists and researchers to drive progress in science and industry.

Contact

Address: 3281 E Guasti Rd
Ontario, CA 91761, United States
Phone: (601) 213-4426
Email: info@benchchem.com

Contact our Ph.D. Support Team for a compatibility check