

Technical Support Center: Optimizing Pacritinib Concentration for In Vitro Studies

Author: BenchChem Technical Support Team. **Date:** April 2026

Compound of Interest

Compound Name:	Quecitinib
CAS No.:	2416858-84-7
Cat. No.:	B15610593

[Get Quote](#)

Disclaimer: The compound "**Quecitinib**" was not found in available scientific literature. This guide has been developed based on data for Pacritinib, a well-documented kinase inhibitor with a similar naming convention. Researchers should verify the identity of their compound before proceeding.

This guide provides troubleshooting advice and frequently asked questions (FAQs) to help researchers optimize Pacritinib concentration for their in vitro experiments.

Frequently Asked Questions (FAQs)

1. What is Pacritinib and what is its primary mechanism of action?

Pacritinib is a potent and selective inhibitor of Janus kinase 2 (JAK2) and FMS-like tyrosine kinase 3 (FLT3). It functions by binding to the ATP-binding site of these kinases, preventing the phosphorylation of downstream signaling proteins like STATs (Signal Transducers and Activators of Transcription). This action effectively blocks the JAK/STAT signaling pathway, which is crucial for cell growth, differentiation, and survival, and is often dysregulated in myeloproliferative neoplasms and certain leukemias.

2. What is a typical starting concentration range for Pacritinib in cell-based assays?

A typical starting concentration range for in vitro cell-based assays is between 10 nM and 10 μ M. However, the optimal concentration is highly dependent on the cell type and the specific endpoint being measured. For initial dose-response experiments, a logarithmic dilution series (e.g., 10 μ M, 1 μ M, 100 nM, 10 nM, 1 nM) is recommended to determine the IC50 value.

3. How does the IC50 of Pacritinib vary across different cell lines?

The half-maximal inhibitory concentration (IC50) of Pacritinib varies significantly depending on the genetic background of the cell line, particularly the status of JAK2 and FLT3. Cell lines with activating mutations like JAK2-V617F or FLT3-ITD are generally more sensitive.

Table 1: Pacritinib IC50 Values in Various Cell Lines

Cell Line	Cancer Type	Key Mutation(s)	Reported IC50 (nM)	Reference
HEL	Erythroleukemia	JAK2-V617F	23	
Ba/F3-JAK2-V617F	Pro-B Cell Line	JAK2-V617F	22	
MV4-11	Acute Myeloid Leukemia	FLT3-ITD	29	
MOLM-13	Acute Myeloid Leukemia	FLT3-ITD	22	
SET-2	Megakaryoblastic Leukemia	JAK2-V617F	130	

| UT-7 | Erythroleukemia | EPO-dependent | >1,000 | |

4. How should I prepare my Pacritinib stock solution?

Pacritinib is typically soluble in dimethyl sulfoxide (DMSO). To prepare a high-concentration stock solution (e.g., 10 mM), dissolve the powdered Pacritinib in DMSO. Aliquot the stock

solution into smaller volumes to avoid repeated freeze-thaw cycles and store at -20°C or -80°C . When preparing working solutions, dilute the DMSO stock directly into the cell culture medium. Ensure the final concentration of DMSO in the culture medium is low (typically $<0.1\%$) to avoid solvent-induced cytotoxicity.

Troubleshooting Guide

Issue 1: High variability between replicate wells in my cell viability assay.

- Possible Cause 1: Uneven cell seeding. Ensure you have a single-cell suspension and mix the cells thoroughly before and during plating.
- Possible Cause 2: Edge effects on the plate. Evaporation in the outer wells of a microplate can concentrate media components and the drug, affecting cell growth. Avoid using the outermost wells or fill them with sterile PBS to maintain humidity.
- Possible Cause 3: Inaccurate drug dilution. Perform serial dilutions carefully. Use calibrated pipettes and change tips for each dilution step to prevent carryover.

Issue 2: I am not observing the expected decrease in STAT3 phosphorylation after treatment.

- Possible Cause 1: Sub-optimal drug concentration. The IC_{50} for inhibiting a specific signaling event (like p-STAT3) may be different from the IC_{50} for cell viability. Try a higher concentration or a broader dose-response range.
- Possible Cause 2: Insufficient treatment time. Phosphorylation events can be rapid. For signaling pathway analysis, shorter treatment times (e.g., 30 minutes to 4 hours) are often more appropriate than longer incubations used for viability assays (e.g., 24-72 hours).
- Possible Cause 3: Issues with antibody or Western blot protocol. Confirm that your primary and secondary antibodies are working correctly. Run positive and negative controls. Ensure efficient protein lysis and transfer.

Issue 3: My vehicle control (DMSO) is showing significant cytotoxicity.

- Possible Cause 1: DMSO concentration is too high. Most cell lines can tolerate DMSO up to 0.1%, but some are more sensitive. Perform a DMSO toxicity curve for your specific cell line

to determine the maximum tolerated concentration.

- Possible Cause 2: Poor quality DMSO. Use a high-purity, sterile-filtered DMSO suitable for cell culture applications.

Troubleshooting Flowchart

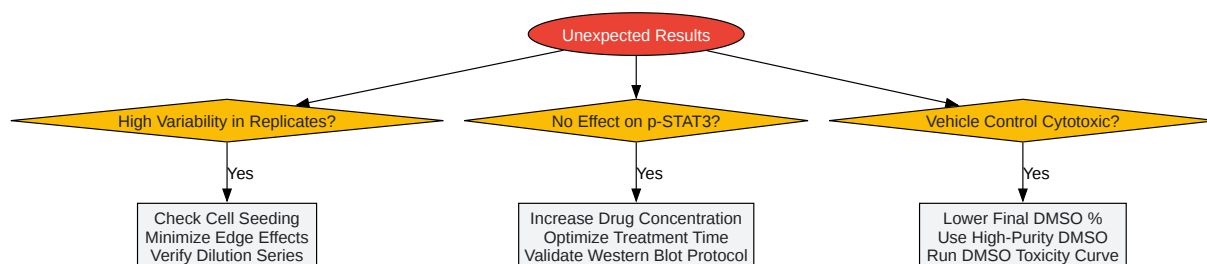

[Click to download full resolution via product page](#)

Caption: Troubleshooting unexpected experimental outcomes.

Experimental Protocols

Protocol 1: Dose-Response Cell Viability Assay (MTT-based)

- Cell Seeding: Plate cells in a 96-well plate at a predetermined optimal density (e.g., 5,000-10,000 cells/well) and allow them to adhere overnight.
- Drug Preparation: Prepare a 2X serial dilution of Pacritinib in culture medium. Also, prepare a 2X vehicle control (e.g., 0.2% DMSO in medium).
- Treatment: Remove the old medium from the cells and add 100 μ L of the 2X drug dilutions or vehicle control to the appropriate wells. This will result in a 1X final concentration.
- Incubation: Incubate the plate for the desired duration (e.g., 72 hours) at 37°C and 5% CO₂.

- **MTT Addition:** Add 20 μL of MTT solution (5 mg/mL in PBS) to each well and incubate for 4 hours.
- **Solubilization:** Carefully remove the medium and add 150 μL of DMSO to each well to dissolve the formazan crystals.
- **Measurement:** Read the absorbance at 570 nm using a microplate reader.
- **Analysis:** Normalize the absorbance values to the vehicle control and plot the dose-response curve to calculate the IC50.

Protocol 2: Western Blot for Phospho-STAT3 Inhibition

- **Cell Treatment:** Seed cells in a 6-well plate. Once they reach 70-80% confluency, starve them in a low-serum medium if required. Treat with various concentrations of Pacritinib (e.g., 0, 10, 100, 1000 nM) for a short duration (e.g., 2 hours).
- **Lysis:** Wash cells with ice-cold PBS and lyse them in RIPA buffer supplemented with protease and phosphatase inhibitors.
- **Quantification:** Determine the protein concentration of each lysate using a BCA or Bradford assay.
- **SDS-PAGE:** Load equal amounts of protein (e.g., 20-30 μg) onto a polyacrylamide gel and separate the proteins by electrophoresis.
- **Transfer:** Transfer the separated proteins to a PVDF or nitrocellulose membrane.
- **Blocking:** Block the membrane with 5% non-fat milk or BSA in TBST for 1 hour at room temperature.
- **Primary Antibody Incubation:** Incubate the membrane overnight at 4°C with primary antibodies against phospho-STAT3 (Tyr705) and total STAT3.
- **Secondary Antibody Incubation:** Wash the membrane and incubate with an appropriate HRP-conjugated secondary antibody for 1 hour at room temperature.

- Detection: Detect the signal using an enhanced chemiluminescence (ECL) substrate and image the blot.
- Analysis: Quantify the band intensities and normalize the p-STAT3 signal to the total STAT3 signal.

Visualizations

Pacritinib Mechanism of Action

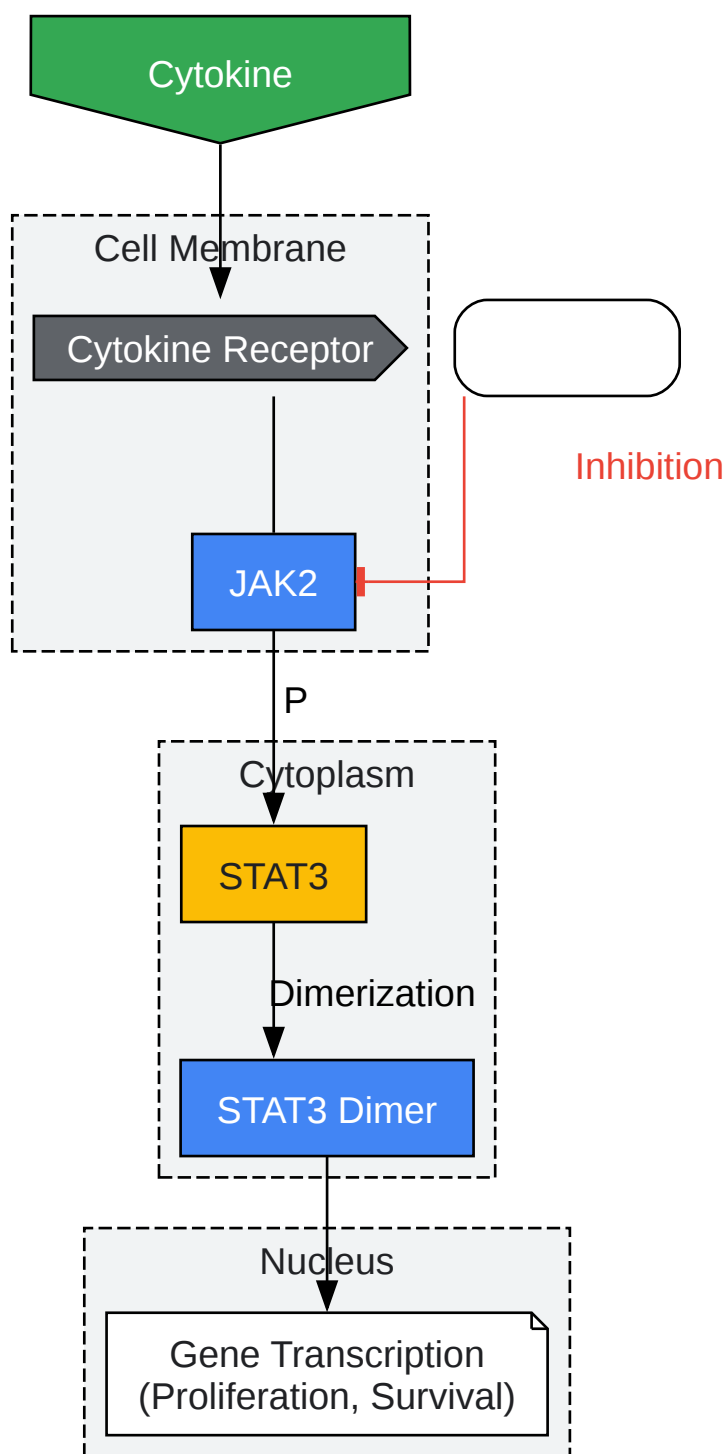

[Click to download full resolution via product page](#)

Caption: Pacritinib inhibits JAK2, blocking STAT3 phosphorylation.

Experimental Workflow for Concentration Optimization

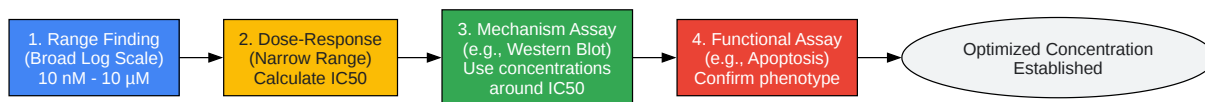

[Click to download full resolution via product page](#)

Caption: Workflow for determining optimal drug concentration.

- To cite this document: BenchChem. [Technical Support Center: Optimizing Pacritinib Concentration for In Vitro Studies]. BenchChem, [2026]. [Online PDF]. Available at: [\[https://www.benchchem.com/product/b15610593/docs#technical-support-center-optimizing-pacritinib-concentration-for-in-vitro-studies\]](https://www.benchchem.com/product/b15610593/docs#technical-support-center-optimizing-pacritinib-concentration-for-in-vitro-studies)

Disclaimer & Data Validity:

The information provided in this document is for Research Use Only (RUO) and is strictly not intended for diagnostic or therapeutic procedures. While BenchChem strives to provide accurate protocols, we make no warranties, express or implied, regarding the fitness of this product for every specific experimental setup.

Technical Support: The protocols provided are for reference purposes. Unsure if this reagent suits your experiment?

Need Industrial/Bulk Grade? [Request Custom Synthesis Quote](#)

BenchChem

Our mission is to be the trusted global source of essential and advanced chemicals, empowering scientists and researchers to drive progress in science and industry.

Contact

Address: 3281 E Guasti Rd
Ontario, CA 91761, United States
Phone: (601) 213-4426
Email: info@benchchem.com

Contact our Ph.D. Support Team for a compatibility check