

# Technical Support Center: Improving JX237 Stability in Experimental Buffers

**Author:** BenchChem Technical Support Team. **Date:** April 2026

## Compound of Interest

Compound Name: JX237  
Cat. No.: B15610390

[Get Quote](#)

This technical support center provides researchers, scientists, and drug development professionals with troubleshooting guides and frequently asked questions (FAQs) to ensure the stable and effective use of **JX237** in experimental settings.

## Frequently Asked Questions (FAQs)

Q1: What is **JX237** and what is its mechanism of action?

**JX237** is an inhibitor of the epithelial neutral amino acid transporter B<sup>0</sup>AT1 (SLC6A19).[1] SLC6A19 is the primary transporter for the absorption of neutral amino acids in the intestine and their reabsorption in the kidneys.[1] By inhibiting this transporter, **JX237** can be used to study disorders of amino acid metabolism.[1]

Q2: What are the known storage conditions for **JX237** stock solutions?

For long-term storage, it is recommended to store **JX237** stock solutions at -80°C for up to 6 months. For shorter-term storage, -20°C for up to 1 month is advised.[1]

Q3: What is the chemical structure of **JX237** and are there any potential stability concerns based on it?

The molecular formula for **JX237** is  $C_{11}H_{15}BrN_2O$ .<sup>[2]</sup> Its chemical structure contains an amide functional group, which can be susceptible to hydrolysis under certain pH and temperature conditions. This is a key consideration when preparing and using experimental buffers.

Q4: Are there any established experimental buffers in which **JX237** has been shown to be stable and active?

Yes, published research has successfully utilized **JX237** in buffered solutions. Specific examples include:

- Hanks' Balanced Salt Solution (HBSS) supplemented with glucose and buffered to pH 7.5 for transport assays.<sup>[3]</sup>
- HBSS supplemented with 10 mM HEPES and 10 mM glucose, at a pH of 7.2 for high-throughput screening assays.<sup>[4]</sup>

## Troubleshooting Guide

| Issue   | Potential Cause  | Recommended Solution  |
|---|--|---|
| Precipitation of JX237 in aqueous buffer  | Poor Aqueous Solubility: JX237, like many small molecules, may have limited solubility in purely aqueous solutions. The addition of the DMSO stock solution to the buffer can cause it to crash out. | Optimize Co-solvent<br>Concentration: Ensure the final concentration of DMSO (or other organic solvent) is kept to a minimum, typically $\leq 1\%$ , to avoid off-target effects. However, a slight, empirically determined increase in the co-solvent percentage may be necessary to maintain solubility. Always include a vehicle control with the same final solvent concentration.                            |
| Loss of JX237 activity over time in experimental buffer   | Hydrolysis: The amide group in JX237's structure may be undergoing hydrolysis, especially at non-optimal pH or elevated temperatures.  | pH Optimization: Maintain a stable pH within the range of 7.2-7.5, as has been used in successful experiments.[3][4]<br>Avoid highly acidic or basic buffers. Temperature Control: Prepare fresh working solutions of JX237 for each experiment and avoid prolonged storage at room temperature or 37°C. For longer experiments, consider running assays at a lower temperature if the biological system permits. |
| Oxidation: The compound may be sensitive to oxidative degradation, which can be accelerated by exposure to air and light. | Use of Antioxidants: If oxidation is suspected, consider adding antioxidants like ascorbic acid or dithiothreitol (DTT) to the buffer. Protect from Light: Store JX237 solutions in                  |   |

|   |   |  |
|---|---|--|
|   | <p>amber vials or wrap containers in foil to minimize light exposure.</p>   |  |
| Inconsistent experimental results   | <p>Adsorption to Labware: Small molecules can adsorb to the surface of plastic tubes and plates, reducing the effective concentration in the assay.</p> | <p><b>Use Low-Binding Plastics:</b><br/>Utilize low-protein-binding microplates and tubes.</p> <p><b>Inclusion of a Surfactant:</b><br/>Adding a small amount of a non-ionic surfactant, such as Tween-20 (e.g., 0.01%), to the buffer can help prevent adsorption. Ensure the surfactant is compatible with your assay.</p> |
| Repeated Freeze-Thaw Cycles: Repeatedly freezing and thawing stock solutions can lead to degradation of the compound. | <p>Aliquot Stock Solutions:<br/>Prepare single-use aliquots of your JX237 stock solution to avoid multiple freeze-thaw cycles.</p>                      |  |

## Data Presentation

Table 1: Recommended Buffer Compositions for **JX237** Experiments

| Buffer Component                     | Concentration | Purpose   | Reference |
|--------------------------------------|---------------|---|-----------|
| Hanks' Balanced Salt Solution (HBSS) | 1x            | Provides a salt and ion balance compatible with cellular assays.      | [3][4]    |
| Glucose                              | 5.6-10 mM     | Energy source for cells.  | [3][4]    |
| HEPES                                | 10 mM         | Buffering agent to maintain stable pH.                                | [4]       |
| pH                                   | 7.2 - 7.5     | Optimal pH range for JX237 activity and stability in reported assays. | [3][4]    |

## Experimental Protocols

### Protocol 1: Preparation of **JX237** Working Solution and Stability Assessment

This protocol provides a general method for preparing a **JX237** working solution and assessing its stability in a chosen experimental buffer.

- Preparation of **JX237** Stock Solution:
  - Prepare a 10 mM stock solution of **JX237** in 100% DMSO.
  - Aliquot the stock solution into single-use vials and store at -80°C.
- Preparation of Experimental Buffer:
  - Prepare 1x HBSS supplemented with 10 mM glucose and 10 mM HEPES.
  - Adjust the pH to 7.4 using NaOH or HCl.
  - Filter-sterilize the buffer.

- Preparation of **JX237** Working Solution:
  - On the day of the experiment, thaw a single-use aliquot of the 10 mM **JX237** stock solution.
  - Perform a serial dilution of the stock solution in your experimental buffer to achieve the desired final concentration. Ensure the final DMSO concentration does not exceed 1%.
  - Visually inspect the solution for any signs of precipitation.
- Stability Assessment (Optional but Recommended):
  - Incubate the **JX237** working solution at the intended experimental temperature (e.g., 37°C).
  - At various time points (e.g., 0, 1, 2, 4, 8, 24 hours), take an aliquot of the solution.
  - Analyze the concentration of the parent **JX237** compound in each aliquot using HPLC or LC-MS.
  - Calculate the percentage of **JX237** remaining at each time point relative to the 0-hour sample to determine its stability under your experimental conditions.

## Mandatory Visualization

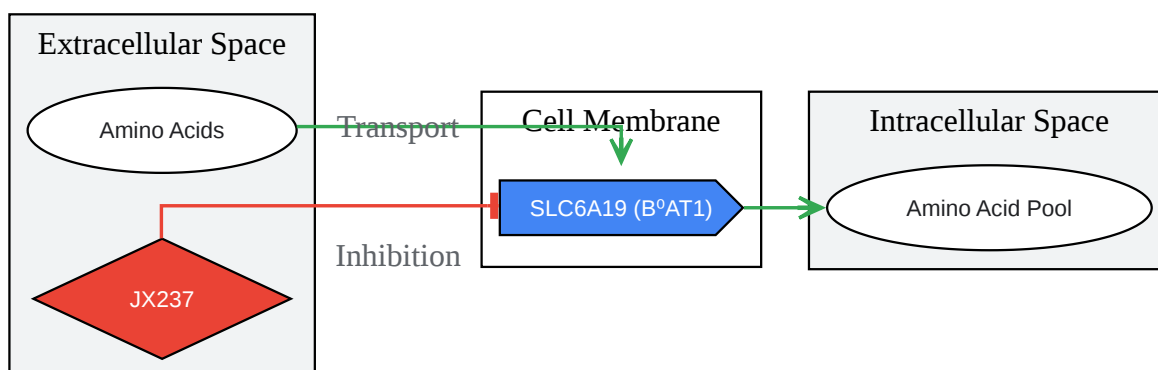

[Click to download full resolution via product page](#)

Caption: Mechanism of **JX237** inhibition of the SLC6A19 amino acid transporter.

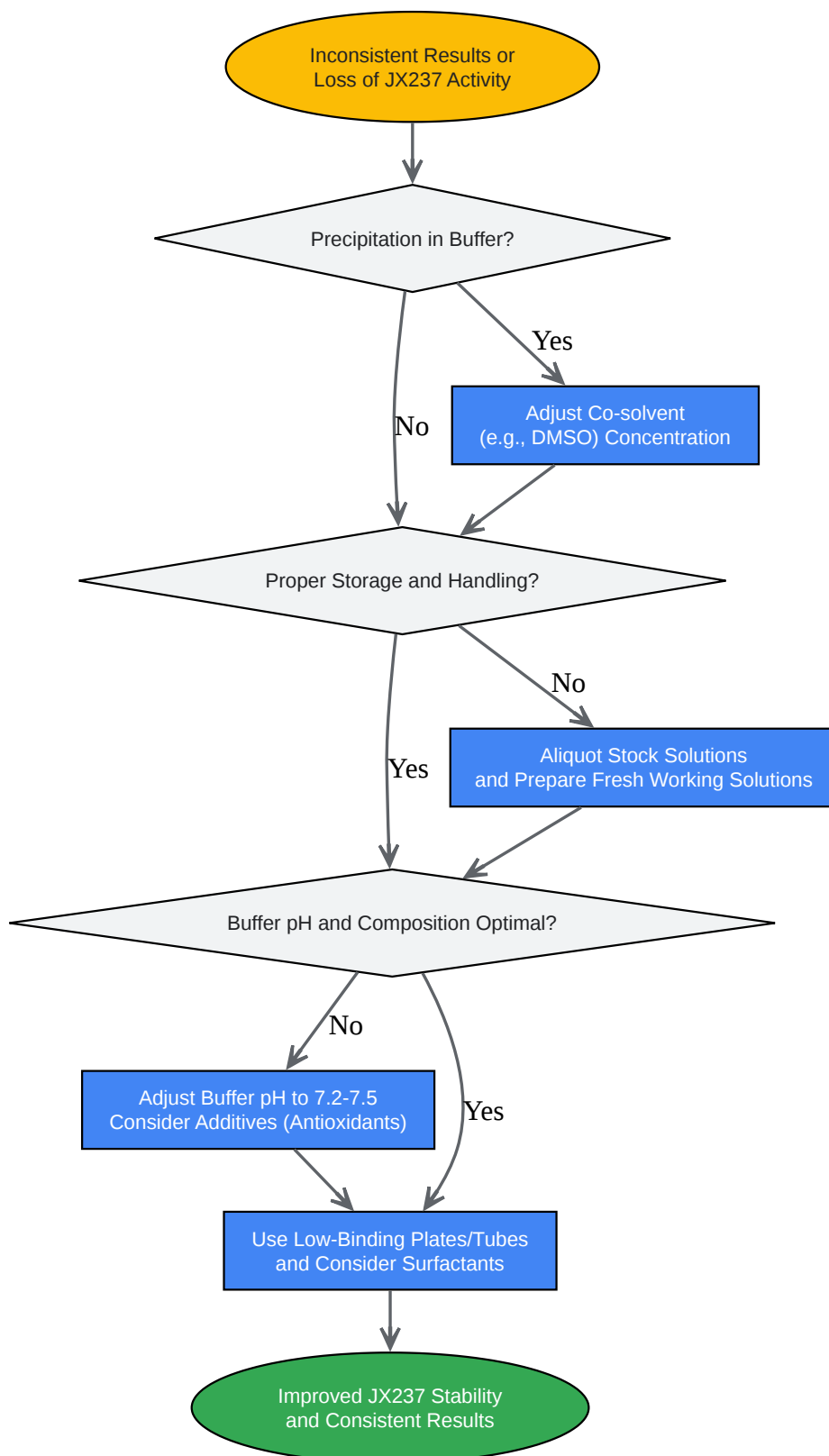

[Click to download full resolution via product page](#)

Caption: Troubleshooting workflow for improving **JX237** stability.

### Need Custom Synthesis?

BenchChem offers custom synthesis for rare earth carbides and specific isotopic labeling.

Email: [info@benchchem.com](mailto:info@benchchem.com) or [Request Quote Online](#).

## References

- 1. [medchemexpress.com](https://www.medchemexpress.com) [[medchemexpress.com](https://www.medchemexpress.com)]
- 2. [JX237](https://chembk.com) [[chembk.com](https://chembk.com)]
- 3. Molecular basis of inhibition of the amino acid transporter B0AT1 (SLC6A19) - PMC [[pmc.ncbi.nlm.nih.gov](https://pubmed.ncbi.nlm.nih.gov/)]
- 4. [researchgate.net](https://www.researchgate.net) [[researchgate.net](https://www.researchgate.net)]
- To cite this document: BenchChem. [Technical Support Center: Improving JX237 Stability in Experimental Buffers]. BenchChem, [2026]. [Online PDF]. Available at: [<https://www.benchchem.com/product/b15610390/docs#technical-support-center-improving-jx237-stability-in-experimental-buffers>]

---

### Disclaimer & Data Validity:

The information provided in this document is for Research Use Only (RUO) and is strictly not intended for diagnostic or therapeutic procedures. While BenchChem strives to provide accurate protocols, we make no warranties, express or implied, regarding the fitness of this product for every specific experimental setup.

**Technical Support:** The protocols provided are for reference purposes. Unsure if this reagent suits your experiment?

**Need Industrial/Bulk Grade?** [Request Custom Synthesis Quote](#)

# BenchChem

Our mission is to be the trusted global source of essential and advanced chemicals, empowering scientists and researchers to drive progress in science and industry.

## Contact

Address: 3281 E Guasti Rd

Ontario, CA 91761, United States

Phone: (601) 213-4426

Email: [info@benchchem.com](mailto:info@benchchem.com)

[Contact our Ph.D. Support Team for a compatibility check](#)