

# Technical Support Center: GNE 220 Hydrochloride

**Author:** BenchChem Technical Support Team. **Date:** April 2026

## Compound of Interest

Compound Name: GNE 220  
Cat. No.: B15610907

[Get Quote](#)

This technical support center provides guidance for researchers, scientists, and drug development professionals on the proper handling and dissolution of **GNE 220** hydrochloride in DMSO.

## Frequently Asked Questions (FAQs)

Q1: What is the recommended solvent for dissolving **GNE 220** hydrochloride?

A1: The recommended solvent for preparing stock solutions of **GNE 220** hydrochloride is Dimethyl Sulfoxide (DMSO).

Q2: What is the solubility of **GNE 220** hydrochloride in DMSO?

A2: The solubility of **GNE 220** hydrochloride in DMSO is 5.4 mg/mL, which corresponds to a concentration of 11.37 mM.<sup>[1][2][3]</sup> It is important to note that sonication is recommended to facilitate dissolution.<sup>[1][2][3]</sup>

Q3: What are the recommended storage conditions for **GNE 220** hydrochloride powder and its DMSO stock solution?

A3: **GNE 220** hydrochloride as a solid powder should be stored at -20°C in a dry and dark place for up to one year.[1] Stock solutions in DMSO should be aliquoted and stored at -80°C for up to six months or -20°C for up to one month.[2] Avoid repeated freeze-thaw cycles.

Q4: Can I use water to dissolve **GNE 220** hydrochloride?

A4: Yes, **GNE 220** hydrochloride also has a solubility of 5 mg/mL (10.53 mM) in water, and sonication is also required.[1][3] However, for creating stock solutions for cell-based assays, DMSO is generally the preferred solvent.

Q5: How does **GNE 220** hydrochloride work?

A5: **GNE 220** hydrochloride is a potent and selective inhibitor of MAP4K4 (Mitogen-Activated Protein Kinase Kinase Kinase Kinase 4), with an IC<sub>50</sub> of 7 nM.[1][4][5] By inhibiting MAP4K4, it can modulate downstream signaling pathways involved in various cellular processes.

## Quantitative Data Summary

The following table summarizes the key quantitative information for **GNE 220** hydrochloride.

Property	Value
Molecular Weight	474.99 g/mol
Solubility in DMSO	5.4 mg/mL (11.37 mM)
Solubility in H <sub>2</sub> O	5.0 mg/mL (10.53 mM)
IC <sub>50</sub> for MAP4K4	7 nM

## Experimental Protocol: Dissolving **GNE 220** Hydrochloride in DMSO

This protocol details the steps for preparing a stock solution of **GNE 220** hydrochloride in DMSO.

Materials:

- **GNE 220** hydrochloride powder
- Anhydrous/molecular biology grade Dimethyl Sulfoxide (DMSO), preferably from a new, unopened bottle[2]
- Sterile microcentrifuge tubes or vials
- Vortex mixer
- Water bath sonicator

#### Procedure:

- **Equilibrate Reagents:** Allow the **GNE 220** hydrochloride powder and DMSO to come to room temperature before opening to prevent condensation.
- **Weigh Compound:** Carefully weigh the desired amount of **GNE 220** hydrochloride powder in a sterile microcentrifuge tube.
- **Add DMSO:** Add the appropriate volume of DMSO to the tube to achieve the desired concentration (not exceeding 5.4 mg/mL).
- **Initial Mixing:** Briefly vortex the mixture to disperse the powder.
- **Sonication:** Place the tube in a water bath sonicator and sonicate for 10-15 minutes to aid dissolution. The solution should become clear.
- **Visual Inspection:** Visually inspect the solution to ensure that all the solid has dissolved. If not, repeat the sonication for another 5-10 minutes.
- **Storage:** Aliquot the stock solution into smaller volumes in sterile tubes and store at -80°C for long-term storage or -20°C for short-term storage.

## Troubleshooting Guide

Issue 1: **GNE 220** hydrochloride is not fully dissolving in DMSO.

- **Possible Cause 1:** Concentration is too high.

- Solution: Ensure the target concentration does not exceed the maximum solubility of 5.4 mg/mL. If a higher concentration is needed, a different solvent system may be required.
- Possible Cause 2: Insufficient mixing or sonication.
  - Solution: Increase the duration of vortexing and/or sonication. Gentle warming of the solution (e.g., to 37°C) may also help, but be cautious of potential compound degradation.
- Possible Cause 3: Poor quality or hydrated DMSO.
  - Solution: Use a fresh, unopened bottle of anhydrous or molecular biology grade DMSO.<sup>[2]</sup> DMSO is hygroscopic and absorbed water can reduce the solubility of some compounds.

Issue 2: Precipitate forms after the stock solution is prepared or stored.

- Possible Cause 1: Solution was not fully dissolved initially.
  - Solution: Re-sonicate the solution. If the precipitate persists, it may indicate that the solubility limit was exceeded.
- Possible Cause 2: Improper storage.
  - Solution: Ensure the stock solution is stored at the recommended temperature (-80°C or -20°C) and that the storage container is properly sealed to prevent solvent evaporation. Avoid repeated freeze-thaw cycles by preparing smaller aliquots.

Issue 3: Inconsistent experimental results.

- Possible Cause 1: Inaccurate concentration of the stock solution.
  - Solution: Re-prepare the stock solution, paying close attention to accurate weighing and volume measurements.
- Possible Cause 2: Degradation of the compound.
  - Solution: Use a freshly prepared stock solution or one that has been stored properly for less than the recommended duration. Protect the stock solution from light.

# Visualizations

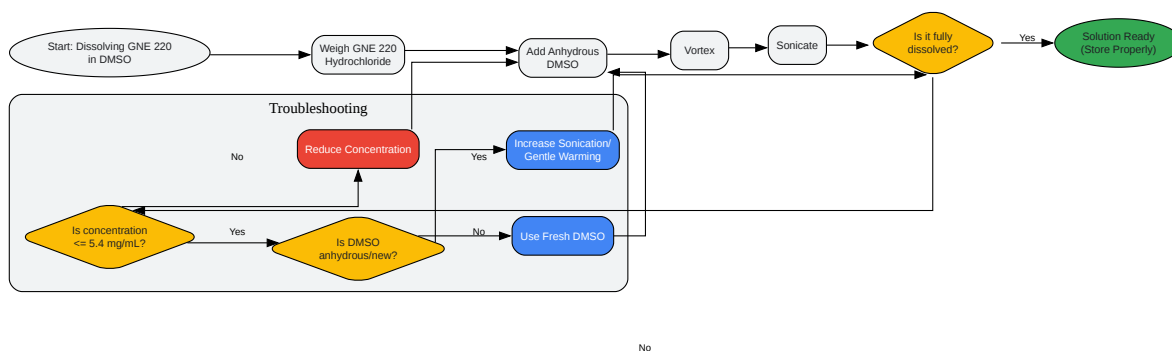

[Click to download full resolution via product page](#)

Caption: Troubleshooting workflow for dissolving **GNE 220** hydrochloride.

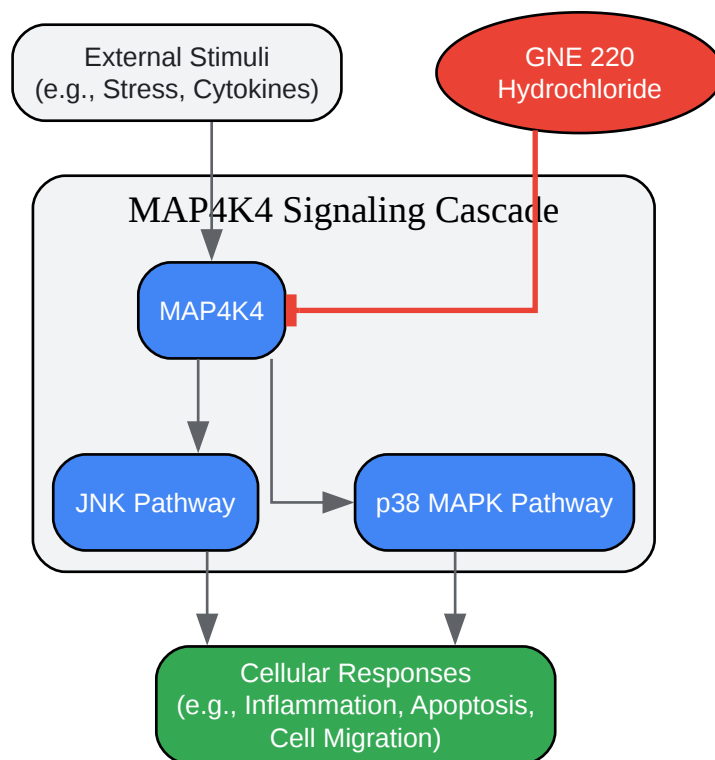

[Click to download full resolution via product page](#)

Caption: Simplified MAP4K4 signaling pathway and the inhibitory action of **GNE 220**.

### Need Custom Synthesis?

BenchChem offers custom synthesis for rare earth carbides and specific isotopic labeling.

Email: [info@benchchem.com](mailto:info@benchchem.com) or [Request Quote Online](#).

## References

- 1. [xcessbio.com](https://www.xcessbio.com) [[xcessbio.com](https://www.xcessbio.com)]
- 2. [medchemexpress.com](https://www.medchemexpress.com) [[medchemexpress.com](https://www.medchemexpress.com)]
- 3. [labsolu.ca](https://www.labsolu.ca) [[labsolu.ca](https://www.labsolu.ca)]
- 4. [medchemexpress.com](https://www.medchemexpress.com) [[medchemexpress.com](https://www.medchemexpress.com)]
- 5. [GNE 220 hydrochloride - Immunomart](https://www.immunomart.com) [[immunomart.com](https://www.immunomart.com)]

- To cite this document: BenchChem. [Technical Support Center: GNE 220 Hydrochloride]. BenchChem, [2026]. [Online PDF]. Available at: [<https://www.benchchem.com/product/b15610907/docs#technical-support-center-gne-220-hydrochloride>]

---

### Disclaimer & Data Validity:

The information provided in this document is for Research Use Only (RUO) and is strictly not intended for diagnostic or therapeutic procedures. While BenchChem strives to provide accurate protocols, we make no warranties, express or implied, regarding the fitness of this product for every specific experimental setup.

**Technical Support:** The protocols provided are for reference purposes. Unsure if this reagent suits your experiment?

**Need Industrial/Bulk Grade?** [Request Custom Synthesis Quote](#)

## BenchChem

Our mission is to be the trusted global source of essential and advanced chemicals, empowering scientists and researchers to drive progress in science and industry.

### Contact

Address: 3281 E Guasti Rd  
Ontario, CA 91761, United States  
Phone: (601) 213-4426  
Email: [info@benchchem.com](mailto:info@benchchem.com)

[Contact our Ph.D. Support Team for a compatibility check](#)